

The George Whalley Company



COOLANT-FED TOOLING & SYSTEMS





CATALOG GUIDE

	Brand new product offerings.
	Visit our website at www.coolantfedtooling.com for technical information and our latest product offerings.
	Expanded offering of an existing product line in either sizes and/or coatings.
	For hole concentricity we recommend using Series 605 Spotting Drill, see page 14.
	We offer drill resharpener and reconditioning for all of our Drills. We also offer a variety of specialized drill points for specific applications. Please contact us for further information.
	These products will be discontinued as a standard, stocked, catalog item and may no longer be offered when inventory is depleted. Please contact a George Whalley Company representative for further assistance and/or questions regarding outgoing parts. These parts may be available as special order items.
	Products highlighted are currently not standard, stocked catalog items. Please check availability at time of order.
	Product does not conform to ANSI specifications. Request further information if needed.

LIABILITY

Any warranty implied by law, including warranties of merchantability or fitness for a particular purpose, are hereby disclaimed and excluded. No representative or person is authorized to give any other warranty or to assume for The George Whalley Company. The George Whalley Company will not be liable for any incidental or consequential damages. The products illustrated in this catalog are protected by United States and foreign patents, patents pending, and applied for. We have attempted to publish this catalog error free, however, we recommend inspection of tool dimensions prior to use. In addition, dimensions shown reflect current manufacturing standards and The George Whalley Company reserves the right to make changes, without notice, to incorporate design improvements.

WARNING:

CUTTING TOOLS MAY SHATTER! ALWAYS WEAR EYE PROTECTION IN THE AREA OF THEIR USE.



TABLE OF CONTENTS

PAGE

 <p>COOLANT-FED DRILLS</p>		Series 605 Spotting Drill – Cobalt – Straight Shank	14
		Series 303 Stub Length – High Speed – Straight Shank – Parabolic Flute	15
		Series 803 Stub Length – High Speed – Straight Shank	14
		Series M604 Stub Length – Metric – Parabolic – Cobalt – TIN Coated – CNC Shank	15
		Series 609 High Performance Jobber Length Twist Drill – High Speed Cobalt – ASP 30 Powdered Metal/Hardlube Coated – Fast Spiral – Parabolic Flute	13
		Series 804 Taper Length – High Speed – Straight Shank	16
		Series M804 Taper Length – Metric – High Speed – Straight Shank	19
		Series 805 Taper Length – Slow Spiral – High Speed – Straight Shank	17
		Series 601 Taper Length – Cobalt – Straight Shank	18
		Series 806 Long Length – Small Diameter – High Speed – Straight Shank	19
		Series 602 Long Length – Small Diameter – Cobalt – Straight Shank	20
		Series 307 Extra Length – 7” Flute – Parabolic – High Speed – Straight Shank	20
		Series 808 Extra Length – 9” Flute – High Speed – Straight Shank	21
		Series 603 Extra Length – 9” Flute – Cobalt – Straight Shank	22
		Series 710 Extra Length – 10” Flute – High Speed – Straight Shank	23
		Series 712 Extra Length – 12” Flute – High Speed – Straight Shank	24
		Series 718 Extra Length – 18” Flute – High Speed – Straight Shank	25
		Series 721 Extra Length – 21” Flute – High Speed – Straight Shank	25
		Series 802 Standard Length – High Speed – Taper Shank	28
		Series 807 Extra Length – 7” Flute – High Speed – Taper Shank	29
		Series 809 Extra Length – 9” Flute – High Speed – Taper Shank	30
		Series 810 Extra Length – 10” Flute – High Speed – Taper Shank	31
		Series 812 Extra Length – 12” Flute – High Speed – Taper Shank	32
		Series 814 Extra Length – 14” Flute – High Speed – Taper Shank	33
		Series 817 Extra Length – 17” Flute – High Speed – Taper Shank	34
		Series 819 Extra Length – 19” Flute – High Speed – Taper Shank	35
		Series 822 Super Length – High Speed – Taper Shank	35
		Series 724 Super Length – High Speed – Taper Shank	35
		Series 903 Stub Length – Carbide Tip – Parabolic – Straight Shank	26
		Series M903 Stub Length – Carbide Tip – Parabolic – Straight Shank – Metric	26
		Series 905 Taper Length – Carbide Tip – Straight Shank	27
	Series M905 Taper Length – Carbide Tip – Straight Shank – Metric	26	



TABLE OF CONTENTS

PAGE



COOLANT-FED DRILLS

	Series 908 Extra Length – Carbide Tip – 9” Flute – Straight Shank	27
	Series M908 Extra Length – Carbide Tip – 9” Flute – Straight Shank – Metric	26
	Series 910 High Performance Jobber Length – Solid Carbide – TiN Coated – Straight Shank	8
	Series 911 High Performance Jobber Length – Solid Carbide – TiAlN Coated – Straight Shank	8
	Series M910 High Performance Jobber Length Metric – Solid Carbide – TiN Coated – Straight Shank	9
	Series M911 High Performance Jobber Length Metric – Solid Carbide – TiAlN Coated – Straight Shank	9
	Series 912 High Performance Extended Length Twist Drill – Solid Carbide – Ultra Gold Coated – 2 Flute – Parabolic – Common Shank	10
	Series 914 High Performance Extended Length Twist Drill – Solid Carbide – Ultra Gold Coated – 3 Flute – Parabolic – Common Shank	10
	Series 916 High Performance Jobber Length Twist Drill – Solid Carbide – ALTiN Coated – Common Shank	11
	Series M916 High Performance Metric Drill – Solid Carbide – ALTiN Coated – Common Shank	11
	Series 917 High Performance Extended Length Twist Drill – Solid Carbide – ALTiN Coated – Common Shank	12
	Series M917 High Performance Extended Length Metric Drill – Solid Carbide – ALTiN Coated – Common Shank	12
	Series 918 High Performance Jobber Length Twist Drill – Solid Carbide – ALTiN Coated – Common Shank	13
	Series M918 High Performance Metric Drill – Solid Carbide – ALTiN Coated – Common Shank	13
	Series 919 High Performance – Solid Carbide – (5X) Drill – Ultra-Bronze Coated	5
	Series M919 High Performance – Solid Carbide – (5X) Drill – Metric – Ultra-Bronze Coated	6
	Series 920 High Performance – Solid Carbide – (7X) Drill – Ultra-Bronze Coated	7
	Series M920 High Performance – Solid Carbide – (7X) Drill – Metric – Ultra-Bronze Coated	7



COOLANT-FED END MILLS AND MILLING CHUCKS

	Series 921 Corner Radius Rougher – High Performance End Mill – Three Flute – Solid Carbide – Ultra Gold Coating – Straight Shank	36
	Series 922 Finisher High Performance End Mill – Three Flute – Solid Carbide – Ultra Gold Coating – Straight Shank	36
	Hurricane Series 923 Corner Radius – High Performance End Mill – Four Individual Flutes – Solid Carbide – Proprietary Six Coat Finish	36
	Hurricane Series 924 Square Corner – High Performance End Mill – Four Individual Flutes – Solid Carbide – Proprietary Six Coat Finish	36
	Series PMC Precision Milling Chucks	37



COOLANT-FED REAMERS AND T-SLOT CUTTERS

	Series 606 Chucking Reamers – C-2 Carbide Tip – Straight Shank	39
	Series S606 Chucking Reamers – Special Decimal Size – C-2 Carbide Tip – Straight Shank	39
	Series 607 Chucking Reamers – M42 Cobalt Steel – Straight Shank	38
	Series S607 Chucking Reamers – Special Decimal Size – M42 Cobalt Steel – Straight Shank	38
	Series 608 Heat Exchange Reamers – M42 Cobalt Steel – Taper Shank	40



TABLE OF CONTENTS

PAGE

 COOLANT-FED REAMERS AND T-SLOT CUTTERS		Series S608 Heat Exchange Reamers – Special Decimal Size – <i>M42 Cobalt Steel</i> – Taper Shank	40
 COOLANT FED TAPS		Series 810 T-Slot Cutters – <i>Super Cobalt Steel</i>	41
 SPADE BLADES & HOLDERS		Throw-Away Spade Drill Inserts and Holders	46
 AUTOMATIC TOOL CHANGE		V-Flange, BT, and Kearney & Trecker shank Collet Chucks, End Mill, Morse Taper, and ABS® Modular Holders with ATC coolant glands	78
 ROTARY COOLANT TOOLHOLDERS		V-Flange, NMTB, Morse Taper, Straight, and Automotive Adjustable shank Collet Chuck, End Mill, Morse Taper Holders and Adapters	112
 STANDARD TOOL HOLDERS		V-Flange, BT, and Kearney & Trecker shank Collet Chuck, End Mill, Shell Mill, Face Mill, Jacobs and Morse Taper Holders.	124
 MODULAR TOOLHOLDERS		Modular Holders Stub Projection, Modular Holders Standard Projection, Extensions, Reducers, Collet Chucks, End Mills	136
 COLLETS		Sealed ER Coolant Style, ER Style, TGNP Style, TG Style, DA Style	144
 TAPPING SYSTEMS		V-Flange & BT shank Tap Holders, Tap Adapters, Tap Extensions in Tension Compression, Quick Change, and Bilz Styles.	148
 ACCESSORIES		Stop Screws, Adapters, Wrenches, Compression Nosepieces, Morse Taper Reducing Sleeve	156
 RETENTION KNOBS		Retention Knobs	163
INDEX		Index	168



HURRICANE • HIGH PERFORMANCE • SOLID CARBIDE • (5X) DRILL • STRAIGHT SHANK • ULTRA-BRONZE COATED

HURRICANE • COOLANT FED



NEW

SERIES: 919

SIZES

1/8" - 9/16"
INCH

High Performance, Solid Carbide, (5X) drill. Designed for ultra performance drilling in a broad range of materials, including mild steel, alloy steel, stainless steel, and super alloys. This solid carbide coolant drill combined with our advanced Ultra-Bronze coating makes this your drill of choice.

MATERIAL	BRIGHT	DARK	ULTRA-BRONZE
SOLID CARBIDE			●
SPECIFICATIONS			
Helix: 30°			
Point: 142°			
Web: Constant Rolled Heel			

DIAMETER		SHANK (IN.)	OAL (IN.)	FLUTE LENGTH (IN.)	PART NUMBER
INCH	DECIMAL				
1/8	0.1250	1/8	3.00	1.125	919-01250
9/64	0.1406	5/32	3.15	1.260	919-01406
5/32	0.1562	5/32	3.15	1.260	919-01562
11/64	0.1719	3/16	3.23	1.500	919-01719
3/16	0.1875	3/16	3.23	1.500	919-01875
13/64	0.2031	15/64	3.23	1.580	919-02031
7/32	0.2187	15/64	3.23	1.580	919-02187
15/64	0.2344	15/64	3.23	1.580	919-02344
1/4	0.2500	1/4	3.30	1.740	919-02500
17/64	0.2656	5/16	3.58	1.890	919-02656
9/32	0.2812	5/16	3.58	1.890	919-02812
19/64	0.2969	5/16	3.58	1.890	919-02969
5/16	0.3125	5/16	3.58	1.890	919-03125
21/64	0.3281	25/64	4.06	2.170	919-03281
11/32	0.3438	25/64	4.06	2.170	919-03438
23/64	0.3594	25/64	4.06	2.170	919-03594
3/8	0.3750	25/64	4.06	2.170	919-03750
25/64	0.3906	25/64	4.06	2.170	919-03906
13/32	0.4062	15/32	4.72	2.360	919-04062
27/64	0.4219	15/32	4.72	2.360	919-04219
7/16	0.4375	15/32	4.72	2.600	919-04375
15/32	0.4688	15/32	4.72	2.600	919-04688
31/64	0.4844	1/2	4.75	2.830	919-04844
1/2	0.5000	1/2	4.75	2.830	919-05000
33/64	0.5156	35/64	5.28	3.030	919-05156
35/64	0.5469	35/64	5.28	3.030	919-05469
9/16	0.5625	5/8	5.51	3.150	919-05625

TECHNICAL TIPS



We offer drill resharpening and reconditioning for all of our Drills. We also offer a variety of specialized drill points for specific applications. Please contact us for further information.



Visit our website at www.coolantfedtooling.com for technical information and our latest product offerings.



HURRICANE • HIGH PERFORMANCE • SOLID CARBIDE • (5X) DRILL • METRIC • STRAIGHT SHANK • ULTRA-BRONZE COATED

HURRICANE • COOLANT FED



SERIES: M919

SIZES

3.0-14.0
MM

High Performance, Solid Carbide, (5X) metric drill. Designed for ultra performance drilling in a broad range of materials, including mild steel, alloy steel, stainless steel, and super alloys. This solid carbide coolant drill combined with our advanced Ultra-Bronze coating makes this your drill of choice.

MATERIAL	BRIGHT	DARK	ULTRA-BRONZE
SOLID CARBIDE			●
SPECIFICATIONS			
Helix: 30°			
Point: 142°			
Web: Constant Rolled Heel			

TOOL DIAMETER		SHANK DIA. (MM)	OAL (MM)	FLUTE LENGTH (MM)	PART NUMBER
MM	DECIMAL				
3.0	0.1181	3.0	75	24	M919-01181
3.2	0.1260	4.0	80	32	M919-01260
3.3	0.1299	4.0	80	32	M919-01299
3.4	0.1339	4.0	80	32	M919-01339
3.5	0.1378	4.0	80	32	M919-01378
3.7	0.1457	4.0	80	32	M919-01457
3.8	0.1496	4.0	80	32	M919-01496
4.0	0.1575	4.0	80	32	M919-01575
4.2	0.1654	5.0	82	38	M919-01654
4.5	0.1772	5.0	82	38	M919-01772
4.6	0.1811	5.0	82	38	M919-01811
4.8	0.1890	5.0	82	38	M919-01890
4.9	0.1929	5.0	82	38	M919-01929
5.0	0.1968	5.0	82	38	M919-01968
5.1	0.2008	6.0	82	40	M919-02008
5.2	0.2047	6.0	82	40	M919-02047
5.3	0.2087	6.0	82	40	M919-02087
5.4	0.2126	6.0	82	40	M919-02126
5.5	0.2165	6.0	82	40	M919-02165
5.7	0.2244	6.0	82	40	M919-02244
5.8	0.2283	6.0	82	40	M919-02283
5.9	0.2323	6.0	82	40	M919-02323
6.0	0.2362	6.0	82	40	M919-02362
6.1	0.2402	8.0	91	48	M919-02402
6.2	0.2441	8.0	91	48	M919-02441
6.3	0.2480	8.0	91	48	M919-02480
6.4	0.2520	8.0	91	48	M919-02520
6.5	0.2559	8.0	91	48	M919-02559
6.8	0.2667	8.0	91	48	M919-02677
6.9	0.2717	8.0	91	48	M919-02717
7.0	0.2756	8.0	91	48	M919-02756
7.2	0.2835	8.0	91	48	M919-02835
7.4	0.2913	8.0	91	48	M919-02913

Non-Stocked Items

TOOL DIAMETER		SHANK DIA. (MM)	OAL (MM)	FLUTE LENGTH (MM)	PART NUMBER
MM	DECIMAL				
7.5	0.2953	8.0	91	48	M919-02953
7.6	0.2992	8.0	91	48	M919-02992
7.7	0.3031	8.0	91	48	M919-03031
7.8	0.3071	8.0	91	48	M919-03071
8.0	0.3150	8.0	91	48	M919-03150
8.1	0.3189	10.0	103	55	M919-03189
8.2	0.3228	10.0	103	55	M919-03228
8.3	0.3268	10.0	103	55	M919-03268
8.5	0.3346	10.0	103	55	M919-03346
8.8	0.3465	10.0	103	55	M919-03465
8.9	0.3504	10.0	103	55	M919-03504
9.0	0.3543	10.0	103	55	M919-03543
9.2	0.3622	10.0	103	55	M919-03622
9.25	0.3642	10.0	103	55	M919-03642
9.3	0.3661	10.0	103	55	M919-03661
9.5	0.3740	10.0	103	55	M919-03740
9.7	0.3819	10.0	103	55	M919-03819
9.8	0.3858	10.0	103	55	M919-03858
10.0	0.3937	10.0	103	55	M919-03937
10.2	0.4016	12.0	120	60	M919-04016
10.5	0.4134	12.0	120	60	M919-04134
11.0	0.4331	12.0	120	60	M919-04331
11.2	0.4409	12.0	120	66	M919-04409
11.5	0.4527	12.0	120	66	M919-04527
11.7	0.4606	12.0	120	66	M919-04606
12.0	0.4724	12.0	120	66	M919-04724
12.1	0.4764	14.0	126	72	M919-04764
12.5	0.4921	14.0	126	72	M919-04921
12.8	0.5039	14.0	126	72	M919-05039
13.0	0.5118	14.0	126	72	M919-05118
13.5	0.5315	14.0	134	77	M919-05315
13.7	0.5394	14.0	134	77	M919-05394
14.0	0.5512	14.0	134	77	M919-05512

Non-Stocked Items

TECHNICAL TIPS



We offer drill resharpening and reconditioning for all of our Drills. We also offer a variety of specialized drill points for specific applications. Please contact us for further information.



Visit our website at www.coolantfedtooling.com for technical information and our latest product offerings.



HURRICANE • HIGH PERFORMANCE • SOLID CARBIDE • (7X) DRILL • STRAIGHT SHANK • ULTRA-BRONZE COATED

HURRICANE • COOLANT FED



SERIES: 920

SIZES

1/8"-1/2"
INCH

High Performance, Solid Carbide, (7X) drill. Designed for ultra performance drilling in a broad range of materials, including mild steel, alloy steel, stainless steel, and super alloys. This solid carbide coolant drill combined with our advanced Ultra-Bronze coating makes this your drill of choice.

MATERIAL	BRIGHT	DARK	ULTRA-BRONZE
SOLID CARBIDE			●
SPECIFICATIONS			
Helix: 30°			
Point: 142°			
Web: Constant Rolled Heel			

TOOL DIAMETER		SHANK INCH	OAL INCH	FLUTE LENGTH INCH	PART NUMBER
INCH	DECIMAL				
1/8	0.1250	1/8	3.500	1.500	920-01250
9/64	0.1406	5/32	3.625	1.750	920-01406
5/32	0.1562	5/32	3.625	1.750	920-01562
11/64	0.1719	3/16	3.940	1.750	920-01719
3/16	0.1875	3/16	3.940	1.750	920-01875
13/64	0.2031	15/64	3.940	2.000	920-02031
7/32	0.2187	15/64	3.940	2.000	920-02187
15/64	0.2344	15/64	3.940	2.000	920-02344
1/4	0.2500	1/4	4.310	2.250	920-02500
17/64	0.2656	5/16	4.310	2.375	920-02656
9/32	0.2812	5/16	4.625	2.750	920-02812
19/64	0.2969	5/16	4.625	2.750	920-02969

TOOL DIAMETER		SHANK INCH	OAL INCH	FLUTE LENGTH INCH	PART NUMBER
INCH	DECIMAL				
5/16	0.3125	5/16	4.625	2.750	920-03125
21/64	0.3281	25/64	5.000	3.150	920-03281
11/32	0.3438	25/64	5.000	3.150	920-03438
23/64	0.3594	25/64	5.312	3.340	920-03594
3/8	0.3750	25/64	5.312	3.340	920-03750
25/64	0.3906	25/64	5.312	3.340	920-03906
13/32	0.4062	15/32	5.875	3.625	920-04062
27/64	0.4219	15/32	5.875	3.625	920-04219
7/16	0.4375	15/32	6.100	4.000	920-04375
15/32	0.4688	15/32	6.100	4.000	920-04688
31/64	0.4844	1/2	6.299	4.132	920-04844
1/2	0.5000	1/2	6.299	4.132	920-05000

HURRICANE • HIGH PERFORMANCE • SOLID CARBIDE • (7X) DRILL • METRIC • STRAIGHT SHANK • ULTRA-BRONZE COATED

HURRICANE • COOLANT FED



SERIES: M920

SIZES

3.0-12.0
MM

High Performance, Solid Carbide, (7X) metric drill. Designed for ultra performance drilling in a broad range of materials, including mild steel, alloy steel, stainless steel, and super alloys. This solid carbide coolant drill combined with our advanced Ultra-Bronze coating makes this your drill of choice.

MATERIAL	BRIGHT	DARK	ULTRA-BRONZE
SOLID CARBIDE			●
SPECIFICATIONS			
Helix: 30°			
Point: 142°			
Web: Constant Rolled Heel			

TOOL DIAMETER		SHANK MM	OAL MM	FLUTE LENGTH MM	PART NUMBER
MM	DECIMAL				
3.0	0.1181	3.0	81	33	M920-01181
3.2	0.1260	4.0	92	44	M920-01260
3.3	0.1299	4.0	92	44	M920-01299
3.4	0.1339	4.0	92	44	M920-01339
3.5	0.1378	4.0	92	44	M920-01378
3.7	0.1457	4.0	92	44	M920-01457
3.8	0.1496	4.0	92	44	M920-01496
4.0	0.1575	4.0	92	44	M920-01575
4.2	0.1654	5.0	100	45	M920-01654
4.5	0.1772	5.0	100	45	M920-01772
4.6	0.1811	5.0	100	45	M920-01811
4.8	0.1890	5.0	100	45	M920-01890
4.9	0.1929	5.0	100	45	M920-01929
5.0	0.1968	5.0	100	45	M920-01968
5.1	0.2008	6.0	100	51	M920-02008
5.2	0.2047	6.0	100	51	M920-02047
5.3	0.2087	6.0	100	51	M920-02087
5.4	0.2126	6.0	100	51	M920-02126
5.5	0.2165	6.0	100	51	M920-02165
5.7	0.2244	6.0	100	51	M920-02244
5.8	0.2283	6.0	100	51	M920-02283
5.9	0.2323	6.0	100	51	M920-02323
6.0	0.2362	6.0	100	51	M920-02362
6.1	0.2402	8.0	109	60	M920-02402
6.2	0.2441	8.0	109	60	M920-02441
6.3	0.2480	8.0	109	60	M920-02480
6.4	0.2520	8.0	109	60	M920-02520
6.5	0.2559	8.0	109	60	M920-02559
6.8	0.2667	8.0	109	60	M920-02677
6.9	0.2717	8.0	109	60	M920-02717

Non-Stocked Items

TOOL DIAMETER		SHANK MM	OAL MM	FLUTE LENGTH MM	PART NUMBER
MM	DECIMAL				
7.0	0.2756	8.0	109	60	M920-02756
7.2	0.2835	8.0	118	70	M920-02835
7.4	0.2913	8.0	118	70	M920-02913
7.5	0.2953	8.0	118	70	M920-02953
7.6	0.2992	8.0	118	70	M920-02992
7.7	0.3031	8.0	118	70	M920-03031
7.8	0.3071	8.0	118	70	M920-03071
8.0	0.3150	8.0	118	70	M920-03150
8.1	0.3189	10.0	127	80	M920-03189
8.2	0.3228	10.0	127	80	M920-03228
8.3	0.3268	10.0	127	80	M920-03268
8.5	0.3346	10.0	127	80	M920-03346
8.8	0.3465	10.0	127	80	M920-03465
8.9	0.3504	10.0	127	80	M920-03504
9.0	0.3543	10.0	127	80	M920-03543
9.2	0.3622	10.0	136	85	M920-03622
9.25	0.3642	10.0	136	85	M920-03642
9.3	0.3661	10.0	136	85	M920-03661
9.5	0.3740	10.0	136	85	M920-03740
9.7	0.3819	10.0	136	85	M920-03819
9.8	0.3858	10.0	136	85	M920-03858
10.0	0.3937	10.0	136	85	M920-03937
10.2	0.4016	12.0	149	93	M920-04016
10.5	0.4134	12.0	149	93	M920-04134
11.0	0.4331	12.0	149	93	M920-04331
11.2	0.4409	12.0	155	102	M920-04409
11.5	0.4527	12.0	155	102	M920-04527
11.7	0.4606	12.0	155	102	M920-04606
12.0	0.4724	12.0	155	102	M920-04724

Non-Stocked Items



HIGH PERFORMANCE JOBBER LENGTH • SOLID CARBIDE • TIN COATED • STRAIGHT SHANK

SERIES 910 • COOLANT-FED



SERIES: 910

SIZES

3/16"-1/2"
INCH

High performance, C2 10% Micro Grain Carbide drill with helical coolant holes designed for deep holes 5x diameter. Successfully drills stainless such as 304 and 315, nickel alloy materials, cast iron aluminum and some carbon steels. Increase production with higher speed/feed rates and decreased cycle times.

MATERIAL	BRIGHT	DARK	TIN
C2 MICROGRAIN			●
SPECIFICATIONS			
Helix: 30° Standard			
Point: 135° S point			
Web: Standard			

TOOL DIAMETER		SHANK DIA. (IN.)	FLUTE LENGTH (IN.)	OAL (IN.)	PART NUMBER
INCH	DECIMAL				
* 3/16	0.1875	0.1875	1-5/8	2-3/4	910-01875
* 13/64	0.2031	0.2031	1-3/4	3	910-02031
* 7/32	0.2187	0.2187	1-3/4	3	910-02187
* 15/64	0.2344	0.2344	2	3-1/4	910-02344
* 1/4	0.2500	0.2500	2	3-1/4	910-02500
* 17/64	0.2656	0.2656	2-1/8	3-1/2	910-02656
* 9/32	0.2812	0.2812	2-1/8	3-1/2	910-02812
* 19/64	0.2969	0.2969	2-3/8	3-3/4	910-02969
* 5/16	0.3125	0.3125	2-3/8	3-3/4	910-03125
* 21/64	0.3281	0.3281	2-1/2	4	910-03281
* 11/32	0.3438	0.3438	2-1/2	4	910-03438
* 23/64	0.3594	0.3594	2-3/4	4-1/4	910-03594

* **Outgoing Items**

TOOL DIAMETER		SHANK DIA. (IN.)	FLUTE LENGTH (IN.)	OAL (IN.)	PART NUMBER
INCH	DECIMAL				
* 3/8	0.3750	0.3750	2-3/4	4-1/4	910-03750
* 25/64	0.3906	0.3906	2-7/8	4-1/2	910-03906
* 13/32	0.4062	0.4062	2-7/8	4-1/2	910-04062
* 27/64	0.4219	0.4219	2-7/8	4-1/2	910-04219
* 7/16	0.4375	0.4375	2-7/8	4-1/2	910-04375
* 29/64	0.4531	0.4531	3	4-3/4	910-04531
* 15/32	0.4688	0.4688	3	4-3/4	910-04688
* 31/64	0.4844	0.4844	3	4-3/4	910-04844
* 1/2	0.5000	0.5000	3	4-3/4	910-05000

* **Outgoing Items**

HIGH PERFORMANCE JOBBER LENGTH • SOLID CARBIDE • TiAIN COATED • STRAIGHT SHANK

SERIES 911 • COOLANT-FED



SERIES: 911

SIZES

3/16" - 1/2"
INCH

High performance, C5 tough steel grade carbide with helical coolant holes for deep holes 5x diameter. Designed with a special shaped chisel edge for drilling tough low carbon steel applications at high speeds while maintaining accuracy, straightness and finish. Increase production with higher speed/feed rates and decreased cycle times.

MATERIAL	BRIGHT	DARK	TiAIN
C5 MICROGRAIN			●
SPECIFICATIONS			
Helix: 30° Standard			
Point: 135° S point			
Web: Standard			

TOOL DIAMETER		SHANK DIA. (IN.)	FLUTE LENGTH (IN.)	OAL (IN.)	PART NUMBER
INCH	DECIMAL				
* 3/16	0.1875	0.1875	1-5/8	2-3/4	911-01875
* 13/64	0.2031	0.2031	1-3/4	3	911-02031
* 7/32	0.2187	0.2187	1-3/4	3	911-02187
* 15/64	0.2344	0.2344	2	3-1/4	911-02344
* 1/4	0.2500	0.2500	2	3-1/4	911-02500
* 17/64	0.2656	0.2656	2-1/8	3-1/2	911-02656
* 9/32	0.2812	0.2812	2-1/8	3-1/2	911-02812
* 19/64	0.2969	0.2969	2-3/8	3-3/4	911-02969
* 5/16	0.3125	0.3125	2-3/8	3-3/4	911-03125
* 21/64	0.3281	0.3281	2-1/2	4	911-03281
* 11/32	0.3438	0.3438	2-1/2	4	911-03438

* **Outgoing Items**

TOOL DIAMETER		SHANK DIA. (IN.)	FLUTE LENGTH (IN.)	OAL (IN.)	PART NUMBER
INCH	DECIMAL				
* 23/64	0.3593	0.3594	2-3/4	4-1/4	911-03594
* 3/8	0.3750	0.3750	2-3/4	4-1/4	911-03750
* 25/64	0.3906	0.3906	2-7/8	4-1/2	911-03906
* 13/32	0.4062	0.4062	2-7/8	4-1/2	911-04062
* 27/64	0.4219	0.4219	2-7/8	4-1/2	911-04219
* 7/16	0.4375	0.4375	2-7/8	4-1/2	911-04375
* 29/64	0.4531	0.4531	3	4-3/4	911-04531
* 15/32	0.4688	0.4688	3	4-3/4	911-04688
* 31/64	0.4844	0.4844	3	4-3/4	911-04844
* 1/2	0.5000	0.5000	3	4-3/4	911-05000

* **Outgoing Items**



HIGH PERFORMANCE JOBBER LENGTH • METRIC • SOLID CARBIDE • TIN COATED • STRAIGHT SHANK

SERIES M910 • COOLANT-FED



SERIES: M910

SIZES

4.0-11.0
MM

High performance, C2 10% Micro Grain Carbide drill with helical coolant holes designed for deep holes 5x diameter. Successfully drills stainless such as 304 and 315, nickel alloy materials, cast iron aluminum and some carbon steels. Increase production with higher speed/feed rates and decreased cycle times.

C2 MICROGRAIN	BRIGHT	DARK	TIN
			●
SPECIFICATIONS			
Helix: 30° Standard			
Point: 135° S point			
Web: Standard			

TOOL DIAMETER		SHANK DIA. (MM)	FLUTE LENGTH (MM)	OAL (MM)	PART NUMBER
MM	DECIMAL				
* 4.00	0.1575	6.0	36	74	M910-01575
* 4.50	0.1772	6.0	36	74	M910-01772
* 4.80	0.1890	6.0	44	82	M910-01890
* 5.00	0.1968	6.0	44	82	M910-01968
* 5.50	0.2165	6.0	44	82	M910-02165
* 5.80	0.2283	6.0	44	82	M910-02283
* 6.00	0.2362	6.0	44	82	M910-02362
* 6.50	0.2559	8.0	53	91	M910-02559
* 6.80	0.2677	8.0	53	91	M910-02677
* 7.00	0.2756	8.0	53	91	M910-02756
* 7.50	0.2953	8.0	53	91	M910-02953
* 7.80	0.3071	8.0	53	91	M910-03071

* Outgoing Items

TOOL DIAMETER		SHANK DIA. (MM)	FLUTE LENGTH (MM)	OAL (MM)	PART NUMBER
MM	DECIMAL				
* 8.00	0.3150	8.0	53	91	M910-03150
* 8.50	0.3346	10.0	61	103	M910-03346
* 8.80	0.3465	10.0	61	103	M910-03465
* 9.00	0.3543	10.0	61	103	M910-03543
* 9.50	0.3740	10.0	61	103	M910-03750
* 9.80	0.3858	10.0	61	103	M910-03858
* 10.00	0.3937	10.0	61	103	M910-03937
* 10.20	0.4016	12.0	71	118	M910-04016
* 10.50	0.4134	12.0	71	118	M910-04134
* 10.80	0.4252	12.0	71	118	M910-04252
* 11.00	0.4331	12.0	71	118	M910-04331

* Outgoing Items

HIGH PERFORMANCE JOBBER LENGTH • METRIC • SOLID CARBIDE • TAIN COATED • STRAIGHT SHANK

SERIES M911 • COOLANT-FED



SERIES: M911

SIZES

4.0-11.0
MM

High performance, C5 tough steel grade carbide with helical coolant holes for deep holes 5x diameter. Designed with a special shaped chisel edge for drilling tough low carbon steel applications at high speeds while maintaining accuracy, straightness and finish. Increase production with higher speed/feed rates and decreased cycle times.

C5 MICROGRAIN	BRIGHT	DARK	TAIN
			●
SPECIFICATIONS			
Helix: 30° Standard			
Point: 135° S point			
Web: Standard			

TOOL DIAMETER		SHANK DIA. (MM)	FLUTE LENGTH (MM)	OAL (MM)	PART NUMBER
MM	DECIMAL				
* 4.00	0.1575	6.0	36	74	M911-01575
* 4.50	0.1772	6.0	36	74	M911-01772
* 4.80	0.1890	6.0	44	82	M911-01890
* 5.00	0.1968	6.0	44	82	M911-01968
* 5.50	0.2165	6.0	44	82	M911-02165
* 5.80	0.2283	6.0	44	82	M911-02283
* 6.00	0.2362	6.0	44	82	M911-02362
* 6.50	0.2559	8.0	53	91	M911-02559
* 6.80	0.2677	8.0	53	91	M911-02677
* 7.00	0.2756	8.0	53	91	M911-02756
* 7.50	0.2953	8.0	53	91	M911-02953
* 7.80	0.3071	8.0	53	91	M911-03071

* Outgoing Items

TOOL DIAMETER		SHANK DIA. (MM)	FLUTE LENGTH (MM)	OAL (MM)	PART NUMBER
MM	DECIMAL				
* 8.00	0.3150	8.0	53	91	M911-03150
* 8.50	0.3346	10.0	61	103	M911-03346
* 8.80	0.3465	10.0	61	103	M911-03465
* 9.00	0.3543	10.0	61	103	M911-03543
* 9.50	0.3740	10.0	61	103	M911-03750
* 9.80	0.3858	10.0	61	103	M911-03858
* 10.00	0.3937	10.0	61	103	M911-03937
* 10.20	0.4016	12.0	71	118	M911-04016
* 10.50	0.4134	12.0	71	118	M911-04134
* 10.80	0.4252	12.0	71	118	M911-04252
* 11.00	0.4331	12.0	71	118	M911-04331

* Outgoing Items



HIGH PERFORMANCE EXTENDED LENGTH TWIST DRILL • SOLID CARBIDE/ULTRA-GOLD COATED/TWO FLUTE PARABOLIC • COMMON SHANK

SERIES 912 • COOLANT-FED



NEW



SERIES: 912

SIZES

3/16" - 17/32"
INCH

The Helical Wear Resistant (HWR) point is self-centering, eliminating the need for center drilling and is a low torque, free chip forming design with excellent edge retention when combined with this unique flute form. The parabolic flute eliminates the necessity of "pecking" to clear chips while allowing for much longer useful tool life in regrinding. The combination of unique flute and point configuration provides up to 2.5 times the strength of conventional drill designs. Recommended for non-ferrous materials such as aluminum and aluminum alloys, free machining stainless steel, steel and cast iron and composites.

MATERIAL	BRIGHT	DARK	ULTRA GOLD
Solid Carbide			●
SPECIFICATIONS			
Helix: 30°-40° Variable			
Point: 142° HWR			
Web: Parabolic			

TOOL DIAMETER		SHANK DIA. (IN.)	FLUTE LENGTH (IN.)	OAL (IN.)	PART NUMBER
INCH	DECIMAL				
3/16	0.1875	0.2500	4	6	912-01875
13/64	0.2031	0.2500	4	6	912-02031
7/32	0.2188	0.2500	4	6	912-02188
15/64	0.2344	0.2500	4	6	912-02344
1/4	0.2500	0.2500	4	6	912-02500
17/64	0.2656	0.3750	4	6	912-02656
9/32	0.2812	0.3750	4	6	912-02812
19/64	0.2969	0.3750	4	6	912-02969
5/16	0.3125	0.3750	4	6	912-03125
21/64	0.3281	0.3750	4	6	912-03281
11/32	0.3438	0.3750	4	6	912-03438
23/64	0.3594	0.3750	4	6	912-03594
3/8	0.3750	0.3750	4	6	912-03750
25/64	0.3906	0.5000	4	6	912-03906
13/32	0.4062	0.5000	4	6	912-04062
27/64	0.4219	0.5000	4	6	912-04219
7/16	0.4375	0.5000	4	6	912-04375
29/64	0.4531	0.5000	4	6	912-04531
15/32	0.4688	0.5000	4	6	912-04688
31/64	0.4844	0.5000	4	6	912-04844
1/2	0.5000	0.5000	4	6	912-05000
33/64	0.5156	0.6250	4	6	912-05156
17/32	0.5312	0.6250	4	6	912-05312

HIGH PERFORMANCE EXTENDED LENGTH TWIST DRILL • SOLID CARBIDE/ULTRA-GOLD COATED/THREE FLUTE PARABOLIC • COMMON SHANK

SERIES 914 • COOLANT-FED



NEW



SERIES: 914

SIZES

3/16" - 17/32"
INCH

Designed for a broad spectrum of materials from aluminum, brass, bronze and cast iron to stainless and hardened steels. This design generally provides for a rounder and straighter hole with closer hole tolerances and better hole wall finishes than most conventional two flute drills. Our special 150° point cuts all the way to the center which will allow the drill to start immediately without "walking" while providing excellent chip formation without tearing at or near the center like most other manufacturers' three lip points.



MATERIAL	BRIGHT	DARK	ULTRA GOLD
Solid Carbide			●
SPECIFICATIONS			
Helix: 30°-40° Variable			
Point: 150° 3 Flute			
Web: Standard			

TOOL DIAMETER		SHANK DIA. (IN.)	FLUTE LENGTH (IN.)	OAL (IN.)	PART NUMBER
INCH	DECIMAL				
3/16	0.1875	0.2500	4	6	914-01875
13/64	0.2031	0.2500	4	6	914-02031
7/32	0.2188	0.2500	4	6	914-02188
15/64	0.2344	0.2500	4	6	914-02344
1/4	0.2500	0.2500	4	6	914-02500
17/64	0.2656	0.3750	4	6	914-02656
9/32	0.2812	0.3750	4	6	914-02812
19/64	0.2969	0.3750	4	6	914-02969
5/16	0.3125	0.3750	4	6	914-03125
21/64	0.3281	0.3750	4	6	914-03281
11/32	0.3438	0.3750	4	6	914-03438
23/64	0.3594	0.3750	4	6	914-03594
3/8	0.3750	0.3750	4	6	914-03750
25/64	0.3906	0.5000	4	6	914-03906
13/32	0.4062	0.5000	4	6	914-04062
27/64	0.4219	0.5000	4	6	914-04219
7/16	0.4375	0.5000	4	6	914-04375
29/64	0.4531	0.5000	4	6	914-04531
15/32	0.4688	0.5000	4	6	914-04688
31/64	0.4844	0.5000	4	6	914-04844
1/2	0.5000	0.5000	4	6	914-05000
33/64	0.5156	0.6250	4	6	914-05156
17/32	0.5312	0.6250	4	6	914-05312



HIGH PERFORMANCE JOBBER LENGTH TWIST DRILL • SOLID CARBIDE/AITIN COATED • COMMON SHANK

SERIES 916 • COOLANT-FED / SERIES M916 (METRIC) • COOLANT-FED

SERIES: 916	SERIES: M916
SIZES	SIZES
3/16" - 1/2" INCH	5.0 - 11.0 MM

10% Micro-grain Solid Carbide. High performance solid carbide drill designed for drilling in stainless steels and high temperature alloy materials. 142 high performance point in conjunction with the AITIN coating improves chip clearance and extends tool life in these difficult to machine materials. Common shank sizes for use with Shrink-Fit © and other precision toolholders. Depths to 5x diameter.

MATERIAL	BRIGHT	DARK	AITIN
Solid Carbide			●
SPECIFICATIONS			
Helix: 27° Standard			
Point: 142° HP			
Web: Standard			

SERIES 916 • COOLANT-FED

TOOL DIAMETER		SHANK DIA. (IN.)	FLUTE LENGTH (IN.)	OAL (IN.)	PART NUMBER
INCH	DECIMAL				
3/16	0.1875	0.1875	1-5/8	2-3/4	916-01875
13/64	0.2031	0.2344	1-3/4	3	916-02031
7/32	0.2187	0.2500	1-3/4	3	916-02187
15/64	0.2344	0.2500	2	3-1/4	916-02344
1/4	0.2500	0.2500	2	3-1/4	916-02500
17/64	0.2656	0.3125	2-1/8	3-1/2	916-02656
9/32	0.2812	0.3125	2-1/8	3-1/2	916-02812
19/64	0.2969	0.3125	2-3/8	3-3/4	916-02969
5/16	0.3125	0.3125	2-3/8	3-3/4	916-03125
21/64	0.3281	0.3750	2-1/2	4	916-03281
11/32	0.3438	0.3750	2-1/2	4	916-03438
23/64	0.3594	0.3750	2-3/4	4-1/4	916-03594
3/8	0.3750	0.3750	2-3/4	4-1/4	916-03750
25/64	0.3906	0.4375	2-7/8	4-1/2	916-03906
13/32	0.4062	0.4375	2-7/8	4-1/2	916-04062
27/64	0.4219	0.4375	2-7/8	4-1/2	916-04219
7/16	0.4375	0.4375	2-7/8	4-1/2	916-04375
29/64	0.4531	0.5000	3	4-3/4	916-04531
15/32	0.4688	0.5000	3	4-3/4	916-04688
31/64	0.4844	0.5000	3	4-3/4	916-04844
1/2	0.5000	0.5000	3	4-3/4	916-05000

SERIES M916 (METRIC) • COOLANT-FED

TOOL DIAMETER		SHANK DIA. (MM)	FLUTE LENGTH (MM)	OAL (MM)	PART NUMBER
MM	DECIMAL				
5.00	0.1968	6.0	44	82	M916-01968
5.50	0.2165	6.0	44	82	M916-02165
5.80	0.2283	6.0	44	82	M916-02283
6.00	0.2362	6.0	44	82	M916-02362
6.50	0.2559	8.0	53	91	M916-02559
6.80	0.2677	8.0	53	91	M916-02677
7.00	0.2756	8.0	53	91	M916-02756
7.50	0.2953	8.0	53	91	M916-02953
7.80	0.3071	8.0	53	91	M916-03071
8.00	0.3150	8.0	53	91	M916-03150
8.50	0.3346	10.0	61	103	M916-03346
8.80	0.3465	10.0	61	103	M916-03465
9.00	0.3543	10.0	61	103	M916-03543
9.50	0.3740	10.0	61	103	M916-03740
9.80	0.3858	10.0	61	103	M916-03858
10.00	0.3937	10.0	61	103	M916-03937
10.20	0.4016	12.0	71	118	M916-04016
10.50	0.4134	12.0	71	118	M916-04134
11.00	0.4331	12.0	71	118	M916-04331

TECHNICAL TIPS



Visit our website at www.coolantfedtooling.com for technical information and our latest product offerings.

REQUIRED FOR SPEED AND FEED INFORMATION:

- Material being drilled
- Rockwell (Rc) or Brinell (Bhn) Hardness
- Diameter and Depth of Hole
- Vertical or Horizontal Orientation
- Coolant Pressure of the Machine Tools Coolant Pump
- Type of Tool Holders being used (i.e., Collet Chuck)



HIGH PERFORMANCE EXTENDED LENGTH TWIST DRILL • SOLID CARBIDE/AITIN COATED • COMMON SHANK

SERIES 917 • COOLANT-FED / SERIES M917 (METRIC) • COOLANT-FED

NEW



SERIES: 917	SERIES: M917
SIZES	SIZES
3/16" - 1/2" INCH	5.0 - 11.0 MM

10% Micro-grain Solid Carbide. High performance solid carbide drill designed for drilling in stainless steels and high temperature alloy materials. 142 high performance point in conjunction with the AITIN coating improves chip clearance and extends tool life in these difficult to machine materials. Common shank sizes for use with Shrink-Fit © and other precision toolholders. Depths to 7x diameter. Slotted coolant entry.

MATERIAL	BRIGHT	DARK	AITIN
Solid Carbide			●
SPECIFICATIONS			
Helix: 30° Standard			
Point: 142°			
Web: Standard			

SERIES 917 • COOLANT-FED

SERIES M917 (METRIC) • COOLANT-FED

TOOL DIAMETER		SHANK DIA. (IN.)	FLUTE LENGTH (IN.)	OAL (IN.)	PART NUMBER
INCH	DECIMAL				
3/16	0.1875	0.1875	1-13/16	3-7/8	917-01875
7/32	0.2187	0.2344	2-1/8	4-13/64	917-02187
15/64	0.2344	0.2344	2-1/8	4-13/64	917-02344
1/4	0.2500	0.2500	2-1/4	4-3/8	917-02500
17/64	0.2656	0.3125	2-17/32	5	917-02656
9/32	0.2812	0.3125	2-17/32	5	917-02812
19/64	0.2969	0.3125	2-13/16	5	917-02969
5/16	0.3125	0.3125	2-13/16	5	917-03125
21/64	0.3281	0.3750	3-1/8	5-25/32	917-03281
11/32	0.3438	0.3750	3-1/8	5-25/32	917-03438
3/8	0.3750	0.3750	3-3/8	5-25/32	917-03750
25/64	0.3906	0.4375	3-11/16	6-3/4	917-03906
13/32	0.4062	0.4375	3-11/16	6-3/4	917-04062
27/64	0.4219	0.4375	3-15/16	6-3/4	917-04219
7/16	0.4375	0.4375	3-15/16	6-3/4	917-04375
1/2	0.5000	0.5000	4-1/2	7	917-05000

TOOL DIAMETER		SHANK DIA. (MM)	FLUTE LENGTH (MM)	OAL (MM)	PART NUMBER
MM	DECIMAL				
5.00	0.1968	5.0	45	98	M917-01968
5.50	0.2165	6.0	50	107	M917-02165
6.00	0.2362	6.0	55	107	M917-02362
6.50	0.2559	8.0	62	127	M917-02559
7.00	0.2756	8.0	67	127	M917-02756
7.50	0.2953	8.0	73	127	M917-02953
8.00	0.3150	8.0	73	127	M917-03150
8.50	0.3346	10.0	78	147	M917-03346
9.00	0.3543	10.0	83	147	M917-03543
9.50	0.3740	10.0	91	147	M917-03740
10.00	0.3937	10.0	91	147	M917-03937
10.50	0.4134	12.0	102	171	M917-04134
11.00	0.4331	12.0	102	171	M917-04331

COMMON MACHINING EQUATIONS

SFM =	RPM X Dia. / 3.82
RPM =	3.82 x SFM / Dia.
IPM =	IPT x No. Teeth x RPM
IPT =	IPM / (No. Teeth x RPM)
IPR =	IPM / RPM

- SFM:** SURFACE FEET PER MINUTE
- RPM:** REVOLUTIONS PER MINUTE
- IPM:** INCHES PER MINUTE
- IPT:** INCHES PER TOOTH
- IPR:** INCHES PER REVOLUTION

TECHNICAL TIPS



We offer drill resharpening and reconditioning for all of our Drills. We also offer a variety of specialized drill points for specific applications. Please contact us for further information.



Visit our website at www.coolantfedtooling.com for technical information and our latest product offerings.



HIGH PERFORMANCE JOBBER LENGTH TWIST DRILL • SOLID CARBIDE • COMMON SHANK/AITIN COATED

SERIES 918 • COOLANT-FED / SERIES M918 (METRIC) • COOLANT-FED



SERIES: 918	SERIES: M918
SIZES	SIZES
3/16" - 1/2" INCH	6.00 - 11.00 MM

10% Micro-grain Solid Carbide. High performance solid carbide drill with double margin and 18 degree helix designed for drilling in gray and ductile cast iron and other ferrous materials. 142 high performance point and helix design, in conjunction with the AITIN coating, allows greater strength, and extends tool life in these applications. Common shank sizes for use with Shrink-Fit © and other precision toolholders. Depths to 5x diameter.

MATERIAL	BRIGHT	DARK	AITIN
Solid Carbide			●
SPECIFICATIONS			
Helix: 18° Double Margin			
Point: 142° S point			
Web: Standard			

SERIES 918 • COOLANT-FED

TOOL DIAMETER		SHANK DIA. (IN.)	FLUTE LENGTH (IN.)	OAL (IN.)	PART NUMBER
INCH	DECIMAL				
3/16	0.1875	0.1875	1-3/8	3-27/64	918-01875
7/32	0.2187	0.2344	1-11/16	3-45/64	918-02187
15/64	0.2344	0.2344	1-11/16	3-45/64	918-02344
1/4	0.2500	0.2500	1-3/4	3-7/8	918-02500
17/64	0.2656	0.3125	2	4-5/16	918-02656
9/32	0.2812	0.3125	2-3/16	4-5/16	918-02812
19/64	0.2969	0.3125	2-3/16	4-5/16	918-02969
5/16	0.3125	0.3125	2-3/16	4-5/16	918-03125
21/64	0.3281	0.3750	2-3/8	4-61/64	918-03281
11/32	0.3438	0.3750	2-5/8	4-61/64	918-03438
3/8	0.3750	0.3750	2-5/8	4-61/64	918-03750
25/64	0.3906	0.4375	2-7/8	5-47/64	918-03906
13/32	0.4062	0.4375	3-1/16	5-47/64	918-04062
27/64	0.4219	0.4375	3-1/16	5-47/64	918-04219
7/16	0.4375	0.4375	3-1/16	5-47/64	918-04375
1/2	0.5000	0.5000	3-1/4	5-7/8	918-05000

SERIES M918 (METRIC) • COOLANT-FED

TOOL DIAMETER		SHANK DIA. (MM)	FLUTE LENGTH (MM)	OAL (MM)	PART NUMBER
MM	DECIMAL				
6.00	0.2362	6.0	42	94	M918-02362
7.00	0.2756	8.0	52	110	M918-02756
8.00	0.3150	8.0	56	110	M918-03150
8.50	0.3346	10.0	62	126	M918-03346
9.00	0.3543	10.0	70	126	M918-03543
9.50	0.3740	10.0	70	126	M918-03740
10.00	0.3937	10.0	70	126	M918-03937
11.00	0.4331	12.0	78	146	M918-04331

HIGH PERFORMANCE JOBBER LENGTH TWIST DRILL • H.S. COBALT ASP 30 POWDERED METAL/HARDLUBE COATED • FAST SPIRAL, PARABOLIC FLUTE

SERIES 609 • COOLANT-FED



SERIES: 609	SERIES: 609
SIZES	SIZES
5/32" - 1/2" INCH	4.0 - 12.50 MM

Performs similar to carbide, but is more suitable for a wider range of materials and machine tools. The hardlube treatment with tungsten carbide is excellent for chip evacuation, extending tool life and cutting edge durability. Manufactured with ASP 30 Powdered Metal for longer life and consistent performance. 135 degree split point is suitable for drilling aluminum, tough alloys, standard alloys, stainless steel and tool steel.

MATERIAL	BRIGHT	DARK	HARDLUBE
ASP 30			●
SPECIFICATIONS			
Helix: 32° Parabolic			
Point: 135° Split Point			
Web: Heavy			

TOOL DIAMETER		SHANK DIA. (IN.)	FLUTE LENGTH (IN.)	OAL (IN.)	PART NUMBER
INCH/MM	DECIMAL				
5/32	0.1562	0.1562	1-3/4	4-1/4	609-01562
4.00 MM	0.1575	0.1575	1-3/4	4-1/4	609-01575
11/64	0.1718	0.1718	1-3/4	4-1/4	609-01718
3/16	0.1875	0.1875	1-3/4	4-1/4	609-01875
13/64	0.2031	0.2031	1-3/4	4-1/4	609-02031
5.50 MM	0.2165	0.2165	1-3/4	4-1/4	609-02165
6.00 MM	0.2362	0.2362	1-3/4	4-1/4	609-02362
1/4	0.2500	0.2500	1-3/4	4-1/4	609-02500
6.50 MM	0.2559	0.2559	1-7/8	4-3/8	609-02559
17/64	0.2656	0.2656	1-7/8	4-3/8	609-02656
1"	0.2720	0.2720	2	4-1/2	609-02720
9/32	0.2812	0.2812	2	4-1/2	609-02812
19/64	0.2968	0.2968	2	4-1/2	609-02968
5/16	0.3125	0.3125	2-3/16	4-3/4	609-03125
8.00 MM	0.3150	0.3150	2-1/4	4-3/4	609-03150
21/64	0.3281	0.3281	2-1/4	4-3/4	609-03281

TOOL DIAMETER		SHANK DIA. (IN.)	FLUTE LENGTH (IN.)	OAL (IN.)	PART NUMBER
INCH/MM	DECIMAL				
8.50 MM	0.3346	0.3346	2-3/8	4-7/8	609-03346
11/32	0.3437	0.3437	2-3/8	4-7/8	609-03437
23/64	0.3593	0.3593	2-1/2	5	609-03593
"U"	0.3680	0.3680	2-5/8	5-1/8	609-03680
3/8	0.3750	0.3750	2-5/8	5-1/8	609-03750
25/64	0.3906	0.3906	2-3/4	5-3/8	609-03906
13/32	0.4062	0.4062	2-7/8	5-1/2	609-04062
27/64	0.4218	0.4218	3	5-5/8	609-04218
7/16	0.4375	0.4375	3	5-5/8	609-04375
29/64	0.4531	0.4531	3-1/8	5-3/4	609-04531
15/32	0.4687	0.4687	3-1/4	5-7/8	609-04687
12.00 MM	0.4724	0.4724	3-3/8	6	609-04724
31/64	0.4843	0.4843	3-3/8	6	609-04843
12.50 MM	0.4921	0.4921	3-1/2	6	609-04921
1/2	0.5000	0.5000	3-1/2	6	609-05000



SPOTTING DRILL • COBALT • STRAIGHT SHANK

SERIES 605 • COOLANT-FED



EXPANDED



SERIES: 605

SIZES

1/4" - 1"
INCH

High performance spot drill designed to prevent work hardening conditions caused by lack of lubrication at the drill point on tough or hard materials. Provides fast accurate spotting and single operation centering and chamfering. Match spot drill and follow-up drill point angles to reduce chance of chipping the follow-up drill during initial penetration. Zero body clearance prohibits drilling beyond point angle.

MATERIAL	BRIGHT	DARK	TIN
HSS	●		●
SPECIFICATIONS			
Helix: 22°-24° Standard			
Point: 90°, 120°, 135°, 145°			
Web: Standard			

TOOL DIAMETER INCH	DECIMAL	SHANK DIA. (IN)	FLUTE LENGTH (IN)	OAL (IN)	90° POINT PART NUMBER	120° POINT PART NUMBER	135° POINT PART NUMBER	145° POINT PART NUMBER
1/4	0.2500	0.2500	3/4	2-1/2	605A-0250	605B-0250	605C-0250	*605D-0250
3/8	0.3750	0.3750	1-1/8	3-1/8	605A-0375	605B-0375	605C-0375	*605D-0375
1/2	0.5000	0.5000	1-3/8	3-3/4	605A-0500	605B-0500	605C-0500	*605D-0500
5/8	0.6250	0.6250	1-5/8	4-3/8	605A-0625	605B-0625	605C-0625	*605D-0625
3/4	0.7500	0.7500	1-7/8	5	605A-0750	605B-0750	605C-0750	*605D-0750
1	1.0000	1.0000	2-1/4	6	605A-1000	605B-1000	605C-1000	*605D-1000

*Expanded Offering

STUB LENGTH • HIGH SPEED • STRAIGHT SHANK

SERIES 803 • COOLANT-FED



SERIES: 803

SIZES

9/32"-1"
INCH

General purpose drill works well in materials ranging from soft to medium hard materials. Suitable for both horizontal and vertical drilling. Notched point provides good chip formation when the proper speeds and feeds are applied. Flute web is constant with rolled heel providing maximum chip clearance.

MATERIAL	BRIGHT	DARK	TIN
HSS	●	●	●
SPECIFICATIONS			
Helix: 22°-24° Standard			
Point: 118° Notch			
Web: Standard			

DIAMETER INCH	DECIMAL (IN.)	FLUTE LENGTH (IN.)	OAL (IN.)	PART NUMBER	DIAMETER INCH	DECIMAL (IN.)	FLUTE LENGTH (IN.)	OAL (IN.)	PART NUMBER
9/32	0.2812	2-1/2	4-1/2	803-011	21/32	0.6562	5	7	803-035
19/64	0.2969	2-1/2	4-1/2	803-012	43/64	0.6719	5	7	803-036
5/16	0.3125	2-1/2	4-1/2	803-013	11/16	0.6875	5	7	803-037
21/64	0.3281	2-1/2	4-1/2	803-014	45/64	0.7031	5	7	803-038
11/32	0.3438	2-1/2	4-1/2	803-015	23/32	0.7188	5	7	803-039
23/64	0.3594	2-1/2	4-1/2	803-016	47/64	0.7344	5	7	803-040
3/8	0.3750	2-1/2	4-1/2	803-017	3/4	0.7500	5	7	803-041
25/64	0.3906	3	5	803-018	49/64	0.7656	5	7	803-042
13/32	0.4062	3	5	803-019	25/32	0.7812	5	7	803-043
27/64	0.4219	3	5	803-020	51/64	0.7969	5	7	803-044
7/16	0.4375	3	5	803-021	13/16	0.8125	5	7	803-045
29/64	0.4531	3-1/2	5-1/2	803-022	53/64	0.8281	5	7	803-046
15/32	0.4688	3-1/2	5-1/2	803-023	27/32	0.8438	5	7	803-047
31/64	0.4844	3-1/2	5-1/2	803-024	55/64	0.8594	5	7	803-048
1/2	0.5000	3-1/2	5-1/2	803-025	7/8	0.8750	5	7	803-049
33/64	0.5156	4	6	803-026	57/64	0.8906	5	7	803-050
17/32	0.5312	4	6	803-027	29/32	0.9062	5	7	803-051
35/64	0.5469	4	6	803-028	59/64	0.9219	5	7	803-052
9/16	0.5625	4	6	803-029	15/16	0.9375	5	7	803-053
37/64	0.5781	4-1/2	6-1/2	803-030	61/64	0.9531	5	7	803-054
19/32	0.5938	4-1/2	6-1/2	803-031	31/32	0.9688	5	7	803-055
39/64	0.6094	4-1/2	6-1/2	803-032	63/64	0.9844	5	7	803-056
5/8	0.6250	4-1/2	6-1/2	803-033	1	1.0000	5	7	803-057
41/64	0.6406	5	7	803-034					

- For coolant entry specifications, see page 18.
- Specify finish when ordering where applicable



STUB LENGTH • PARABOLIC • HIGH SPEED • STRAIGHT SHANK

SERIES 303 • COOLANT-FED



EXPANDED



SERIES: 303

SIZES

1/18"-19/64"
INCH

Parabolic style drill performs exceptionally well in aluminum and in most other materials. The 32° helix has excellent shearing action. Higher helix also assists chip flow in the vertical position. Parabolic design gives maximum chip room and lift in deep hole drilling. Split point design is self centering and provides accurate hole locations. **For tough materials and machining applications Ultra-Bronze coating is now available.**

MATERIAL	BRIGHT	ULTRA-BRONZE	TIN
HSS	●	●	●
SPECIFICATIONS			
Helix:	32° Parabolic		
Point:	118° Split		
Web:	Standard		

TOOL DIAMETER		SHANK DIA. (IN.)	FLUTE LENGTH (IN.)	OAL (IN.)	PART NUMBER	TOOL DIAMETER		SHANK DIA. (IN.)	FLUTE LENGTH (IN.)	OAL (IN.)	PART NUMBER
INCH	DECIMAL					INCH	DECIMAL				
1/8	0.1250	0.1250	1-1/2	3-1/2	303-001	7/32	0.2188	0.2187	1-3/4	3-3/4	303-007
9/64	0.1406	0.1406	1-1/2	3-1/2	303-002	15/64	0.2344	0.2344	1-3/4	3-3/4	303-008
5/32	0.1562	0.1562	1-1/2	3-1/2	303-003	1/4	0.2500	0.2500	1-3/4	3-3/4	303-009
11/64	0.1719	0.1719	1-3/4	3-3/4	303-004	17/64	0.2656	0.2656	2	4	303-010
3/16	0.1875	0.1875	1-3/4	3-3/4	303-005	9/32	0.2812	0.2812	2	4	303-011
13/64	0.2031	0.2031	1-3/4	3-3/4	303-006	19/64	0.2969	0.2969	2	4	303-012

• For coolant entry specifications, see page 18.

STUB LENGTH • METRIC • PARABOLIC • COBALT • TIN COATED • CNC SHANK

SERIES M604 • COOLANT-FED



SERIES: M604

SIZES

5.0 - 14.0
MM

Cobalt parabolic style drill with versatile CNC shank works well in most materials and is an outstanding performer in harder materials. Excellent substitute when machines do not have the proper speed and feed for carbide. Parabolic design provides maximum chip room. The stubby length of these drills makes them sturdy. Furnished titanium nitride coated.

MATERIAL	BRIGHT	DARK	TIN
HSCO			●
SPECIFICATIONS			
Helix:	32° Parabolic		
Point:	135° Notch		
Web:	Standard		

TOOL DIAMETER		SHANK DIA. (MM)	FLUTE LENGTH (MM)	OAL (MM)	PART NUMBER
MM	DECIMAL				
5.0	0.1968	6	44	82	M604-0050
5.5	0.2165	6	44	82	M604-0055
6.0	0.2362	6	44	82	M604-0060
6.5	0.2559	8	53	91	M604-0065
6.8	0.2677	8	53	91	M604-0068
7.0	0.2756	8	53	91	M604-0070
7.5	0.2953	8	53	91	M604-0075
7.8	0.3071	8	53	91	M604-0078
8.0	0.3150	8	53	91	M604-0080
8.5	0.3346	10	61	103	M604-0085
9.0	0.3543	10	61	103	M604-0090
9.5	0.3740	10	61	103	M604-0095
10.0	0.3937	10	61	103	M604-0100
10.2	0.4016	12	71	118	M604-0102
10.5	0.4134	12	71	118	M604-0105
11.0	0.4331	12	71	118	M604-0110
11.5	0.4528	12	71	118	M604-0115
12.0	0.4724	12	71	118	M604-0120
12.5	0.4921	14	77	124	M604-0125
13.0	0.5118	14	77	124	M604-0130
13.5	0.5315	14	77	124	M604-0135
14.0	0.5512	14	77	124	M604-0140

• Specify finish when ordering where applicable



TAPER LENGTH • HIGH SPEED • STRAIGHT SHANK

SERIES 804 • COOLANT-FED



SERIES: 804

SIZES

1/8" - 1-1/2"
INCH

General purpose drill works well in materials ranging from soft to medium hard. Suitable for both horizontal and vertical drilling. Notched point provides good chip formation when the proper speeds and feeds are applied. The 22° - 24° helix has constant web thickness with rolled heel providing maximum chip clearance.

MATERIAL	BRIGHT	DARK	TN
HSCO	●	●	●
SPECIFICATIONS			
Helix: 22°-24° Standard			
Point: 118° Notch			
Web: Standard			

DIAMETER INCH	DECIMAL (IN.)	FLUTE LENGTH (IN.)	OAL (IN.)	PART NUMBER	DIAMETER INCH	DECIMAL (IN.)	FLUTE LENGTH (IN.)	OAL (IN.)	PART NUMBER
1/8	0.1250	2-3/8	4-3/4	804-001	43/64	0.6719	6	9-1/4	804-036
9/64	0.1406	2-5/8	5	804-002	11/16	0.6875	6	9-1/4	804-037
5/32	0.1562	2-5/8	5	804-003	45/64	0.7031	6-3/16	9-1/2	804-038
11/64	0.1719	2-7/8	5-1/4	804-004	23/32	0.7188	6-3/16	9-1/2	804-039
3/16	0.1875	2-7/8	5-1/4	804-005	47/64	0.7344	6-3/8	9-3/4	804-040
13/64	0.2031	3-1/8	5-1/2	804-006	3/4	0.7500	6-3/8	9-3/4	804-041
7/32	0.2188	3-1/8	5-1/2	804-007	49/64	0.7656	6-1/2	9-7/8	804-042
15/64	0.2344	3-3/8	5-3/4	804-008	25/32	0.7812	6-1/2	9-7/8	804-043
1/4	0.2500	3-3/8	5-3/4	804-009	51/64	0.7969	6-5/8	10	804-044
17/64	0.2656	3-5/8	6	804-010	13/16	0.8125	6-5/8	10	804-045
9/32	0.2812	3-5/8	6	804-011	53/64	0.8281	6-3/4	10-1/4	804-046
19/64	0.2969	3-7/8	6-1/4	804-012	27/32	0.8438	6-3/4	10-1/4	804-047
5/16	0.3125	3-7/8	6-1/4	804-013	55/64	0.8594	7	10-1/2	804-048
21/64	0.3281	4-1/8	6-1/2	804-014	7/8	0.8750	7	10-1/2	804-049
11/32	0.3438	4-1/8	6-1/2	804-015	57/64	0.8906	7	10-5/8	804-050
23/64	0.3594	4-1/4	6-3/4	804-016	29/32	0.9062	7	10-5/8	804-051
3/8	0.3750	4-1/4	6-3/4	804-017	59/64	0.9219	7	10-3/4	804-052
25/64	0.3906	4-3/8	7	804-018	15/16	0.9375	7	10-3/4	804-053
13/32	0.4062	4-3/8	7	804-019	61/64	0.9531	7-1/8	10-7/8	804-054
27/64	0.4219	4-5/8	7-1/4	804-020	31/32	0.9688	7-1/8	10-7/8	804-055
7/16	0.4375	4-5/8	7-1/4	804-021	63/64	0.9844	7-3/16	11	804-056
29/64	0.4531	4-7/8	7-1/2	804-022	1	1.0000	7-3/16	11	804-057
15/32	0.4688	4-7/8	7-1/2	804-023	1-1/32	1.0313	7-5/16	11-1/8	804-058
31/64	0.4844	5	7-3/4	804-024	1-1/16	1.0625	7-3/8	11-1/4	804-059
1/2	0.5000	5	7-3/4	804-025	1-3/32	1.0938	7-5/8	11-1/2	804-060
33/64	0.5156	5-1/4	8	804-026	1-1/8	1.1250	7-7/8	11-3/4	804-061
17/32	0.5313	5-1/4	8	804-027	1-5/32	1.1563	8	11-7/8	804-062
35/64	0.5469	5-3/8	8-1/4	804-028	1-3/16	1.1875	8-1/8	12	804-063
9/16	0.5625	5-3/8	8-1/4	804-029	1-7/32	1.2188	8-1/8	12-1/8	804-064
37/64	0.5781	5-5/8	8-1/2	804-030	1-1/4	1.2500	8-1/2	12-1/2	804-065
19/32	0.5938	5-5/8	8-1/2	804-031	1-5/16	1.3125	9-1/4	14-1/4	804-066
39/64	0.6094	5-3/4	8-3/4	804-032	1-3/8	1.3750	9-1/2	14-1/2	804-067
5/8	0.6250	5-3/4	8-3/4	804-033	1-7/16	1.4375	9-5/8	14-3/4	804-068
41/64	0.6406	5-7/8	9	804-034	1-1/2	1.5000	9-7/8	15	804-069
21/32	0.6563	5-7/8	9	804-035					

- For coolant entry specifications, see page 18.
- Specify finish when ordering where applicable



TAPER LENGTH • SLOW SPIRAL • HIGH SPEED • STRAIGHT SHANK

SERIES 805 • COOLANT-FED



SERIES: 805
SIZES
5/16" - 1-1/2"
INCH

General purpose slow spiral drill works best in horizontal applications on materials ranging from soft to hard. 14° slow spiral produces uninterrupted chip flow and increases edge strength. Notch point provides good chip formation when the proper speeds and feeds are applied.

MATERIAL	BRIGHT	DARK	TIN
HSS	●	●	●
SPECIFICATIONS			
Helix:	14° Slow		
Point:	118° Notch		
Web:	Standard		

DIAMETER INCH	DECIMAL (IN.)	FLUTE LENGTH (IN.)	OAL (IN.)	PART NUMBER	DIAMETER INCH	DECIMAL (IN.)	FLUTE LENGTH (IN.)	OAL (IN.)	PART NUMBER
5/16	0.3125	3-7/8	6-1/4	805-013	49/64	0.7656	6-1/2	9-7/8	805-042
21/64	0.3281	4-1/8	6-1/2	805-014	25/32	0.7812	6-1/2	9-7/8	805-043
11/32	0.3438	4-1/8	6-1/2	805-015	51/64	0.7969	6-5/8	10	805-044
23/64	0.3594	4-1/4	6-3/4	805-016	13/16	0.8125	6-5/8	10	805-045
3/8	0.3750	4-1/4	6-3/4	805-017	53/64	0.8281	6-3/4	10-1/4	805-046
25/64	0.3906	4-3/8	7	805-018	27/32	0.8438	6-3/4	10-1/4	805-047
13/32	0.4062	4-3/8	7	805-019	55/64	0.8594	7	10-1/2	805-048
27/64	0.4219	4-5/8	7-1/4	805-020	7/8	0.8750	7	10-1/2	805-049
7/16	0.4375	4-5/8	7-1/4	805-021	57/64	0.8906	7	10-5/8	805-050
29/64	0.4531	4-7/8	7-1/2	805-022	29/32	0.9062	7	10-5/8	805-051
15/32	0.4688	4-7/8	7-1/2	805-023	59/64	0.9219	7	10-3/4	805-052
31/64	0.4844	5	7-3/4	805-024	15/16	0.9375	7	10-3/4	805-053
1/2	0.5000	5	7-3/4	805-025	61/64	0.9531	7-1/8	10-7/8	805-054
33/64	0.5156	5-1/4	8	805-026	31/32	0.9688	7-1/8	10-7/8	805-055
17/32	0.5312	5-1/4	8	805-027	63/64	0.9844	7-3/16	11	805-056
35/64	0.5469	5-3/8	8-1/4	805-028	1	1.0000	7-3/16	11	805-057
9/16	0.5625	5-3/8	8-1/4	805-029	1-1/32	1.0313	7-5/16	11-1/8	805-058
37/64	0.5781	5-5/8	8-1/2	805-030	1-1/16	1.0625	7-3/8	11-1/4	805-059
19/32	0.5938	5-5/8	8-1/2	805-031	1-3/32	1.0938	7-5/8	11-1/2	805-060
39/64	0.6094	5-3/4	8-3/4	805-032	1-1/8	1.1250	7-7/8	11-3/4	805-061
5/8	0.6250	5-3/4	8-3/4	805-033	1-5/32	1.1562	8	11-7/8	805-062
41/64	0.6406	5-7/8	9	805-034	1-3/16	1.1875	8-1/8	12	805-063
21/32	0.6562	5-7/8	9	805-035	1-7/32	1.2188	8-1/8	12-1/8	805-064
43/64	0.6719	6	9-1/4	805-036	1-1/4	1.2500	8-1/2	12-1/2	805-065
11/16	0.6875	6	9-1/4	805-037	1-5/16	1.3125	9-1/4	14-1/4	805-066
45/64	0.7031	6-3/16	9-1/2	805-038	1-3/8	1.3750	9-1/2	14-1/2	805-067
23/32	0.7188	6-3/16	9-1/2	805-039	1-7/16	1.4375	9-5/8	14-3/4	805-068
47/64	0.7344	6-3/8	9-3/4	805-040	1-1/2	1.5000	9-7/8	15	805-069
3/4	0.7500	6-3/8	9-3/4	805-041					

- For coolant entry specifications, see page 18.
- Specify finish when ordering where applicable

TECHNICAL TIPS



We offer drill resharpener and reconditioning for all of our Drills. We also offer a variety of specialized drill points for specific applications. Please contact us for further information.



Visit our website at www.coolantfedtooling.com for technical information and our latest product offerings.



TAPER LENGTH • COBALT • STRAIGHT SHANK

SERIES 601 • COOLANT-FED



SERIES: 601

SIZES

3/8"-1"
INCH

Heavy duty cobalt drill designed for use in abrasive or hard materials where speed is not the primary consideration. Heavy web thickness makes this drill extremely sturdy in these tough materials. Does not work well in aluminum or soft steels. Split point design is self centering and provides accurate hole locations.

MATERIAL	BRIGHT	DARK	TIN
HSCO	●		
SPECIFICATIONS			
Helix: 22° -24° Standard			
Point: 135° Split			
Web: Heavy			

DIAMETER INCH	DECIMAL (IN.)	FLUTE LGTH.(IN.)	OAL (IN.)	OLD PART NUMBER	NEW PART NUMBER	DIAMETER INCH	DECIMAL (IN.)	FLUTE LGTH. (IN.)	OAL (IN.)	OLD PART NUMBER	NEW PART NUMBER
3/8	0.3750	4-1/4	6-3/4	C804-017	601-03750	45/64	0.7031	6-3/16	9-1/2	C804-038	601-07031
25/64	0.3906	4-3/8	7	C804-018	601-03906	23/32	0.7188	6-3/16	9-1/2	C804-039	601-07188
13/32	0.4062	4-3/8	7	C804-019	601-04062	47/64	0.7344	6-3/8	9-3/4	C804-040	601-07344
27/64	0.4219	4-5/8	7-1/4	C804-020	601-04219	3/4	0.7500	6-3/8	9-3/4	C804-041	601-07500
7/16	0.4375	4-5/8	7-1/4	C804-021	601-04375	49/64	0.7656	6-1/2	9-7/8	C804-042	601-07656
29/64	0.4531	4-7/8	7-1/2	C804-022	601-04531	25/32	0.7812	6-1/2	9-7/8	C804-043	601-07821
15/32	0.4688	4-7/8	7-1/2	C804-023	601-04688	51/64	0.7968	6-5/8	10	C804-044	601-07968
31/64	0.4844	5	7-3/4	C804-024	601-04844	13/16	0.8125	6-5/8	10	C804-045	601-08125
1/2	0.5000	5	7-3/4	C804-025	601-05000	53/64	0.8281	6-3/4	10-1/4	C804-046	601-08281
33/64	0.5156	5-1/4	8	C804-026	601-05156	27/32	0.8438	6-3/4	10-1/4	C804-047	601-08438
17/32	0.5312	5-1/4	8	C804-027	601-05312	55/64	0.8593	7	10-1/2	C804-048	601-08593
35/64	0.5469	5-3/8	8-1/4	C804-028	601-05469	7/8	0.8750	7	10-1/2	C804-049	601-08750
9/16	0.5625	5-3/8	8-1/4	C804-029	601-05625	57/64	0.8906	7	10-5/8	C804-050	601-08906
37/64	0.5781	5-5/8	8-1/2	C804-030	601-05781	29/32	0.9062	7	10-5/8	C804-051	601-09062
19/32	0.5938	5-5/8	8-1/2	C804-031	601-05938	59/64	0.9218	7	10-3/4	C804-052	601-09218
39/64	0.6094	5-3/4	8-3/4	C804-032	601-06094	15/16	0.9375	7	10-3/4	C804-053	601-09375
5/8	0.6250	5-3/4	8-3/4	C804-033	601-06250	61/64	0.9531	7-1/8	10-7/8	C804-054	601-09531
41/64	0.6406	5-7/8	9	C804-034	601-06406	31/32	0.9687	7-1/8	10-7/8	C804-055	601-09687
21/32	0.6562	5-7/8	9	C804-035	601-06562	63/64	0.9843	7-3/16	11	C804-056	601-09843
43/64	0.6719	6	9-1/4	C804-036	601-06719	1	1.0000	7-3/16	11	C804-057	601-10000
11/16	0.6875	6	9-1/4	C804-037	601-06875						

- For coolant entry specifications, see page below.
- Specify finish when ordering where applicable

COOLANT ENTRY SPECIFICATIONS

STRAIGHT SHANK



Sizes **under 1/2"** have Cupped End Coolant Entry
 Sizes **1/2" through 3/4"** have 1/8 NPT Tapped Coolant Entry
 Sizes **49/64" through 1-1/4"** have 1/4 NPT Tapped Coolant Entry
 Sizes **1-9/32" through 1-3/8"** have 3/8 NPT Tapped Coolant Entry

TAPER SHANK

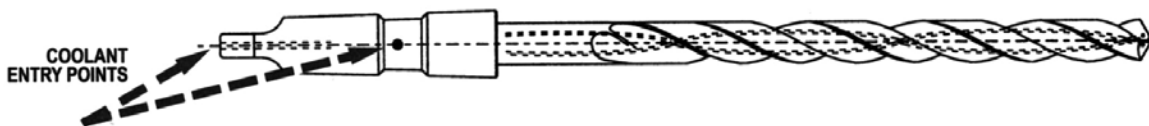

The George Whalley Company standard length taper shank coolant-fed twist drills are normally furnished with side and tang end coolant entry. However, if end entry is an absolute requirement, please specify when ordering.



LONG LENGTH • SMALL DIAMETER • HIGH SPEED • STRAIGHT SHANK

SERIES 806 • COOLANT-FED



SERIES: 806

SIZES

1/8" - 1/2"
INCH

General purpose drill works well in materials ranging from soft to medium hard materials. Suitable for both horizontal and vertical drilling. Notched point provides good chip formation when the proper speeds and feeds are applied. The 22° - 24° helix has constant web thickness with rolled heel providing maximum chip clearance.

MATERIAL	BRIGHT	DARK	TN
HSS	●	●	●
SPECIFICATIONS			
Helix: 22°-24° Standard			
Point: 118° Notch			
Web: Standard			

DIAMETER INCH	DECIMAL (IN.)	FLUTE LENGTH (IN.)	OAL (IN.)	PART NUMBER
1/8	0.1250	3-5/8	6	806-001
9/64	0.1406	4	6-3/8	806-002
5/32	0.1562	4	6-3/8	806-003
11/64	0.1719	4-3/8	6-3/4	806-004
3/16	0.1875	4-3/8	6-3/4	806-005
13/64	0.2031	4-3/4	7-1/8	806-006
7/32	0.2188	4-3/4	7-1/8	806-007
15/64	0.2344	5-1/8	7-1/2	806-008
1/4	0.2500	5-1/8	7-1/2	806-009
17/64	0.2656	5-1/2	7-7/8	806-010
9/32	0.2812	5-1/2	7-7/8	806-011
19/64	0.2969	5-7/8	8-1/4	806-012
5/16	0.3125	5-7/8	8-1/4	806-013

DIAMETER (IN.)	DECIMAL (IN.)	FLUTE LENGTH (IN.)	OAL (IN.)	PART NUMBER
21/64	0.3281	6-1/4	8-5/8	806-014
11/32	0.3438	6-1/4	8-5/8	806-015
23/64	0.3594	6-3/8	8-7/8	806-016
3/8	0.3750	6-3/8	8-7/8	806-017
25/64	0.3906	6-5/8	9-1/4	806-018
13/32	0.4062	6-5/8	9-1/4	806-019
27/64	0.4219	7	9-5/8	806-020
7/16	0.4375	7	9-5/8	806-021
29/64	0.4531	7-3/8	10	806-022
15/32	0.4688	7-3/8	10	806-023
31/64	0.4844	7-1/2	10-1/4	806-024
1/2	0.5000	7-1/2	10-1/4	806-025

• For coolant entry specifications, see page 18.

TAPER LENGTH • METRIC • HIGH SPEED • STRAIGHT SHANK

SERIES M804 • COOLANT-FED



SERIES: M804

SIZES

3.0 - 13.0
MM

General purpose metric drill for use in soft to medium hard materials. Suitable for both horizontal and vertical applications. Higher helix assists chip flow in the vertical position. Notch point provides good chip formation when the proper speeds and feeds are applied

MATERIAL	BRIGHT	DARK	TN
HSS	●		●
SPECIFICATIONS			
Helix: 34° Fast			
Point: 118° Notch			
Web: Standard			

DIAMETER (MM)	DECIMAL (IN.)	FLUTE LENGTH (MM)	OAL (MM)	PART NUMBER
3.0	0.1181	66	100	M804-0030
3.3	0.1299	69	106	M804-0033
3.5	0.1378	73	112	M804-0035
4.0	0.1575	78	119	M804-0040
4.2	0.1654	78	119	M804-0042
4.5	0.1772	82	126	M804-0045
5.0	0.1968	87	132	M804-0050
5.5	0.2165	91	139	M804-0055
6.0	0.2362	91	139	M804-0060
6.5	0.2559	97	148	M804-0065
6.8	0.2677	102	156	M804-0068
7.0	0.2756	102	156	M804-0070

DIAMETER (MM)	DECIMAL (IN.)	FLUTE LENGTH (MM)	OAL (MM)	PART NUMBER
7.5	0.2953	102	156	M804-0075
8.0	0.3150	109	165	M804-0080
8.5	0.3346	109	165	M804-0085
9.0	0.3543	115	175	M804-0090
9.5	0.3740	115	175	M804-0095
10.0	0.3937	121	184	M804-0100
10.2	0.4016	121	184	M804-0102
10.5	0.4134	121	184	M804-0105
11.0	0.4331	128	195	M804-0110
11.5	0.4528	128	195	M804-0115
12.0	0.4724	134	205	M804-0120
13.0	0.5118	134	205	M804-0130

- Meets DIN 34 Specifications
- Specify finish when ordering where applicable



LONG LENGTH • SMALL DIAMETER • COBALT • STRAIGHT SHANK

SERIES 602 • COOLANT-FED



SERIES: 602

SIZES

1/8"-1/2"
INCH

Heavy duty cobalt drill designed for use in abrasive or hard materials where speed is not the primary consideration. Heavy web thickness makes this drill extremely sturdy in these tough materials. Does not work well in aluminum or soft steels. Split point design is self centering and provides accurate hole locations.

MATERIAL	BRIGHT	DARK	TIN
HSCO	●		●
SPECIFICATIONS			
Helix: 22° -24° Standard			
Point: 135° Split			
Web: Heavy			

DIAMETER INCH	DECIMAL (IN.)	FLUTE LGTH. (IN.)	OAL (IN.)	OLD PART NUMBER	PART NUMBER	DIAMETER (IN.)	DECIMAL (IN.)	FLUTE LGTH. (IN.)	OAL (IN.)	OLD PART NUMBER	PART NUMBER
1/8	0.1250	3-5/8	6	C806-001	602-01250	21/64	0.3281	6-1/4	8-5/8	C806-014	602-03281
9/64	0.1406	4	6-3/8	C806-002	602-01406	11/32	0.3438	6-1/4	8-5/8	C806-015	602-03438
5/32	0.1562	4	6-3/8	C806-003	602-01562	23/64	0.3594	6-3/8	8-7/8	C806-016	602-03594
11/64	0.1719	4-3/8	6-3/4	C806-004	602-01719	3/8	0.3750	6-3/8	8-7/8	C806-017	602-03750
3/16	0.1875	4-3/8	6-3/4	C806-005	602-01875	25/64	0.3906	6-5/8	9-1/4	C806-018	602-03906
13/64	0.2031	4-3/4	7-1/8	C806-006	602-02031	13/32	0.4062	6-5/8	9-1/4	C806-019	602-04062
7/32	0.2188	4-3/4	7-1/8	C806-007	602-02188	27/64	0.4219	7	9-5/8	C806-020	602-04219
15/64	0.2344	5-1/8	7-1/2	C806-008	602-02344	7/16	0.4375	7	9-5/8	C806-021	602-04375
1/4	0.2500	5-1/8	7-1/2	C806-009	602-02500	29/64	0.4531	7-3/8	10	C806-022	602-04531
17/64	0.2656	5-1/2	7-7/8	C806-010	602-02656	15/32	0.4688	7-3/8	10	C806-023	602-04688
9/32	0.2812	5-1/2	7-7/8	C806-011	602-02812	31/64	0.4844	7-1/2	10-1/4	C806-024	602-04844
19/64	0.2969	5-7/8	8-1/4	C806-012	602-02969	1/2	0.5000	7-1/2	10-1/4	C806-025	602-05000
5/16	0.3125	5-7/8	8-1/4	C806-013	602-03125						

• For coolant entry specifications, see page 18.

EXTRA LENGTH • 7" FLUTE • PARABOLIC • HIGH SPEED • STRAIGHT SHANK

SERIES 307 • COOLANT-FED

EXPANDED



SERIES: 307

SIZES

1/8" - 3/4"
INCH

Parabolic style drill performs exceptionally well in aluminum and in most other materials. The 32° helix has excellent shearing action. Higher helix also assists chip flow in the vertical position. Parabolic design gives maximum chip room and lift in deep hole drilling. Split point design is self centering and provides accurate hole locations. For tough machining applications Ultra-Bronze coating is available.

MATERIAL	BRIGHT	ULTRA-BRONZE	TIN
HSS	●	●	●
SPECIFICATIONS			
Helix: 32° Parabolic			
Point: 118° Split			
Web: Standard			

TOOL DIAMETER INCH	DECIMAL	SHANK DIA.	FLUTE LENGTH	OAL	PART NUMBER	TOOL DIAMETER INCH	DECIMAL	SHANK DIA.	FLUTE LENGTH	OAL	PART NUMBER
*1/8	0.1250	0.1250	7	10	307-001	7/16	0.4375	0.4375	7	10	307-021
*9/64	0.1406	0.1406	7	10	307-002	29/64	0.4531	0.4531	7	10	307-022
*5/32	0.1563	0.1563	7	10	307-003	15/32	0.4688	0.4688	7	10	307-023
*11/64	0.1719	0.1719	7	10	307-004	31/64	0.4844	0.4688	7	10	307-024
*3/16	0.1875	0.1875	7	10	307-005	1/2	0.5000	0.5000	7	10	307-025
*13/64	0.2031	0.2031	7	10	307-006	33/64	0.5156	0.5156	7	10	307-026
*7/32	0.2188	0.2188	7	10	307-007	17/32	0.5312	0.5312	7	10	307-027
*15/64	0.2344	0.2344	7	10	307-008	35/64	0.5469	0.5469	7	10	307-028
1/4	0.2500	0.2500	7	10	307-009	9/16	0.5625	0.5625	7	10	307-029
17/64	0.2656	0.2656	7	10	307-010	37/64	0.5781	0.5781	7	10	307-030
9/32	0.2812	0.2812	7	10	307-011	19/32	0.5937	0.5937	7	10	307-031
19/64	0.2969	0.2969	7	10	307-012	39/64	0.6094	0.6094	7	10	307-032
5/16	0.3125	0.3125	7	10	307-013	5/8	0.6250	0.6250	7	10	307-033
21/64	0.3281	0.3281	7	10	307-014	41/64	0.6406	0.6406	7	10	307-034
11/32	0.3437	0.3437	7	10	307-015	21/32	0.6562	0.6562	7	10	307-035
23/64	0.3594	0.3594	7	10	307-016	43/64	0.6719	0.6719	7	10	307-036
3/8	0.3750	0.3750	7	10	307-017	11/16	0.6875	0.6875	7	10	307-037
25/64	0.3906	0.3906	7	10	307-018	45/64	0.7031	0.7031	7	10	307-038
13/32	0.4062	0.4062	7-3/4	10-3/4	307-019S	23/32	0.7188	0.7188	7	10	307-039
27/64	0.4219	0.4219	7	10	307-020	47/64	0.7344	0.7344	7	10	307-040
						3/4	0.7500	0.7500	7	10	307-041

*Expanded Offering

• Specify finish when ordering where applicable



For hole concentricity we recommend using **Series 605 Spotting Drill**, see page 14.



EXTRA LENGTH • 9" FLUTE • HIGH SPEED • STRAIGHT SHANK

SERIES 808 • COOLANT-FED



MATERIAL	BRIGHT	DARK	TIN
HSS	●	●	●
SPECIFICATIONS			
Helix: 22° -24° Standard			
Point: 118° Notch			
Web: Standard			

SERIES: 808

SIZES

3/16" - 1-1/16"
INCH

General purpose drill works well in materials ranging from soft to medium hard. Suitable for both horizontal and vertical drilling. Notched point provides good chip formation when the proper speeds and feeds are applied. The 22° to 24° helix has constant web thickness with rolled heel providing maximum chip clearance.

DIAMETER INCH	DECIMAL (IN.)	FLUTE LENGTH (IN.)	OAL (IN.)	PART NUMBER	DIAMETER (IN.)	DECIMAL (IN.)	FLUTE LENGTH (IN.)	OAL (IN.)	PART NUMBER
3/16	0.1875	9	12	808-006	5/8	0.6250	9	12	808-034
13/64	0.2031	9	12	808-007	41/64	0.6406	9	12	808-035
7/32	0.2188	9	12	808-008	21/32	0.6562	9	12	808-036
15/64	0.2344	9	12	808-009	43/64	0.6719	9	12	808-037
1/4	0.2500	9	12	808-010	11/16	0.6875	9	12	808-038
17/64	0.2656	9	12	808-011	45/64	0.7031	9	12	808-039
9/32	0.2812	9	12	808-012	23/32	0.7188	9	12	808-040
19/64	0.2969	9	12	808-013	47/64	0.7344	9	12	808-041
5/16	0.3125	9	12	808-014	3/4	0.7500	9	12	808-042
21/64	0.3281	9	12	808-015	49/64	0.7656	9	12	808-043
11/32	0.3438	9	12	808-016	25/32	0.7812	9	12	808-044
23/64	0.3594	9	12	808-017	51/64	0.7969	9	12	808-045
3/8	0.3750	9	12	808-018	13/16	0.8125	9	12	808-046
25/64	0.3906	9	12	808-019	53/64	0.8281	9	12	808-047
13/32	0.4062	9	12	808-020	27/32	0.8438	9	12	808-048
27/64	0.4219	9	12	808-021	55/64	0.8594	9	12	808-049
7/16	0.4375	9	12	808-022	7/8	0.8750	9	12	808-050
29/64	0.4531	9	12	808-023	57/64	0.8906	9	12	808-051
15/32	0.4688	9	12	808-024	29/32	0.9062	9	12	808-052
31/64	0.4844	9	12	808-025	59/64	0.9219	9	12	808-053
1/2	0.5000	9	12	808-026	15/16	0.9375	9	12	808-054
33/64	0.5156	9	12	808-027	61/64	0.9531	9	12	808-055
17/32	0.5312	9	12	808-028	31/32	0.9688	9	12	808-056
35/64	0.5469	9	12	808-029	63/64	0.9844	9	12	808-057
9/16	0.5625	9	12	808-030	1	1.0000	9	12	808-059
37/64	0.5781	9	12	808-031	1-1/32	1.0313	9	12	808-060
19/32	0.5938	9	12	808-032	1-1/16	1.0625	9	12	808-061
39/64	0.6094	9	12	808-033					

- For coolant entry specifications, see page 18.
- Specify finish when ordering where applicable



For hole concentricity we recommend using **Series 605 Spotting Drill**, see page 14.

TECHNICAL TIPS



We offer drill resharpener and reconditioning for all of our Drills. We also offer a variety of specialized drill points for specific applications. Please contact us for further information.



Visit our website at www.coolantfedtooling.com for technical information and our latest product offerings.



EXTRA LENGTH • 9" FLUTE • COBALT • STRAIGHT SHANK

SERIES 603 • COOLANT-FED



SERIES: 603
SIZES
5/16" - 1-1/16" INCH

Heavy duty cobalt drill designed for use in abrasive or hard materials where speed is not the primary consideration. Heavy web thickness makes this drill extremely sturdy in these tough materials. Does not work well in aluminum or soft steels. Split point design is self centering and provides accurate hole locations.

MATERIAL	BRIGHT	DARK	TIN
HSCO	●		●
SPECIFICATIONS			
Helix: 22° -24° Standard			
Point: 135° Split			
Web: Heavy			

DIAMETER INCH	DECIMAL (IN.)	FLUTE LGTH. (IN.)	OAL (IN.)	OLD PART NO.	PART NUMBER	DIAMETER INCH	DECIMAL (IN.)	FLUTE LGTH. (IN.)	OAL (IN.)	OLD PART NO.	PART NUMBER
5/16	0.3125	9	12	C808-014	603-03125	11/16	0.6875	9	12	C808-038	603-06875
21/64	0.3281	9	12	C808-015	603-03281	45/64	0.7031	9	12	C808-039	603-07031
11/32	0.3437	9	12	C808-016	603-03437	23/32	0.7188	9	12	C808-040	603-07188
23/64	0.3593	9	12	C808-017	603-03593	47/64	0.7344	9	12	C808-041	603-07344
3/8	0.3750	9	12	C808-018	603-03750	3/4	0.7500	9	12	C808-042	603-07500
25/64	0.3906	9	12	C808-019	603-03906	49/64	0.7656	9	12	C808-043	603-07656
13/32	0.4062	9	12	C808-020	603-04062	25/32	0.7812	9	12	C808-044	603-07812
27/64	0.4219	9	12	C808-021	603-04219	51/64	0.7968	9	12	C808-045	603-07968
7/16	0.4375	9	12	C808-022	603-04375	13/16	0.8125	9	12	C808-046	603-08125
29/64	0.4531	9	12	C808-023	603-04531	53/64	0.8281	9	12	C808-047	603-08281
15/32	0.4688	9	12	C808-024	603-04688	27/32	0.8437	9	12	C808-048	603-08437
31/64	0.4844	9	12	C808-025	603-04844	55/64	0.8593	9	12	C808-049	603-08593
1/2	0.5000	9	12	C808-026	603-05000	7/8	0.8750	9	12	C808-050	603-08750
33/64	0.5156	9	12	C808-027	603-05156	57/64	0.8906	9	12	C808-051	603-08906
17/32	0.5312	9	12	C808-028	603-05312	29/32	0.9062	9	12	C808-052	603-09062
35/64	0.5469	9	12	C808-029	603-05469	59/64	0.9218	9	12	C808-053	603-09218
9/16	0.5625	9	12	C808-030	603-05625	15/16	0.9375	9	12	C808-054	603-09375
37/64	0.5781	9	12	C808-031	603-05781	61/64	0.9531	9	12	C808-055	603-09531
19/32	0.5938	9	12	C808-032	603-05938	31/32	0.9687	9	12	C808-056	603-09687
39/64	0.6094	9	12	C808-033	603-06094	63/64	0.9843	9	12	C808-057	603-09843
5/8	0.6250	9	12	C808-034	603-06250	1	1.0000	9	12	C808-059	603-10000
41/64	0.6406	9	12	C808-035	603-06406	1-1/32	1.0312	9	12	C808-060	603-10312
21/32	0.6562	9	12	C808-036	603-06562	1-1/16	1.0625	9	12	C808-061	603-10625
43/64	0.6719	9	12	C808-037	603-06719						

- For coolant entry specifications, see page 18.
- Specify finish when ordering where applicable



For hole concentricity we recommend using **Series 605 Spotting Drill**, see page 14.



Visit our website at www.coolantfedtooling.com for technical information and our latest product offerings.



EXTRA LENGTH • 10" FLUTE • HIGH SPEED • STRAIGHT SHANK

SERIES 710 • COOLANT-FED



SERIES: 710
SIZES
5/16" - 1-3/8"
INCH

General purpose drill works well in materials ranging from soft to medium hard. Suitable for both horizontal and vertical drilling. Notched point provides good chip formation when the proper speeds and feeds are applied. The 22° to 24° helix has constant web thickness with rolled heel providing maximum chip clearance.

MATERIAL	BRIGHT	DARK	TIN
HSS	●	●	●
SPECIFICATIONS			
Helix: 22° -24° Standard			
Point: 118° Notch			
Web: Standard			

DIAMETER INCH	DECIMAL (IN.)	FLUTE LENGTH (IN.)	OAL (IN.)	PART NUMBER	DIAMETER (IN.)	DECIMAL (IN.)	FLUTE LENGTH (IN.)	OAL (IN.)	PART NUMBER
5/16	0.3125	10	13-1/2	710-014A	49/64	0.7656	10	13-1/2	710-043A
21/64	0.3281	10	13-1/2	710-015A	25/32	0.7812	10	13-1/2	710-044A
11/32	0.3438	10	13-1/2	710-016A	51/64	0.7969	10	13-1/2	710-045A
23/64	0.3594	10	13-1/2	710-017A	13/16	0.8125	10	13-1/2	710-046A
3/8	0.3750	10	13-1/2	710-018A	53/64	0.8281	10	13-1/2	710-047A
25/64	0.3906	10	13-1/2	710-019A	27/32	0.8438	10	13-1/2	710-048A
13/32	0.4062	10	13-1/2	710-020A	55/64	0.8594	10	13-1/2	710-049A
27/64	0.4219	10	13-1/2	710-021A	7/8	0.8750	10	13-1/2	710-050A
7/16	0.4375	10	13-1/2	710-022A	57/64	0.8906	10	13-1/2	710-051A
29/64	0.4531	10	13-1/2	710-023A	29/32	0.9062	10	13-1/2	710-052A
15/32	0.4688	10	13-1/2	710-024A	59/64	0.9219	10	13-1/2	710-053A
31/64	0.4844	10	13-1/2	710-025A	15/16	0.9375	10	13-1/2	710-054A
1/2	0.5000	10	13-1/2	710-026A	61/64	0.9531	10	13-1/2	710-055A
33/64	0.5156	10	13-1/2	710-027A	31/32	0.9688	10	13-1/2	710-056A
17/32	0.5312	10	13-1/2	710-028A	63/64	0.9844	10	13-1/2	710-057A
35/64	0.5469	10	13-1/2	710-029A	1	1.0000	10	13-1/2	710-059A
9/16	0.5625	10	13-1/2	710-030A	1-1/32	1.0313	10	13-1/2	710-060A
37/64	0.5781	10	13-1/2	710-031A	1-1/16	1.0625	10	13-1/2	710-061A
19/32	0.5938	10	13-1/2	710-032A	1-3/32	1.0938	10	15	710-062A
39/64	0.6094	10	13-1/2	710-033A	1-1/8	1.1250	10	15	710-063A
5/8	0.6250	10	13-1/2	710-034A	1-5/32	1.1562	10	15	710-064A
41/64	0.6406	10	13-1/2	710-035A	1-3/16	1.1875	10	15	710-065A
21/32	0.6562	10	13-1/2	710-036A	1-7/32	1.2188	10	15	710-066A
43/64	0.6719	10	13-1/2	710-037A	1-1/4	1.2500	10	15	710-067A
11/16	0.6875	10	13-1/2	710-038A	1-9/32	1.2812	10	15	710-068A
45/64	0.7031	10	13-1/2	710-039A	1-5/16	1.3125	10	15	710-069A
23/32	0.7188	10	13-1/2	710-040A	1-11/32	1.3438	10	15	710-070A
47/64	0.7344	10	13-1/2	710-041A	1-3/8	1.3750	10	15	710-071A
3/4	0.7500	10	13-1/2	710-042A					

• For coolant entry specifications, see page 18.

Note: Drill bushing or starter hole recommended when drilling under 3/8 diameter

- Specify finish when ordering where applicable
- Where coatings are not shown by each product, we offer the following coatings: TiN, TiAlN, TiCN, HARDLUBE, ULTRAGOLD and ULTRA-BRONZE.



For hole concentricity we recommend using **Series 605 Spotting Drill**, see page 14.



EXTRA LENGTH • 12" FLUTE • HIGH SPEED • STRAIGHT SHANK

SERIES 712 • COOLANT-FED



SERIES: 712

SIZES

5/16" - 1-3/8"
INCH

General purpose drill works well in materials ranging from soft to medium hard. Suitable for both horizontal and vertical drilling. Notched point provides good chip formation when the proper speeds and feeds are applied. The 22° to 24° helix has constant web thickness with rolled heel providing maximum chip clearance.

MATERIAL	BRIGHT	DARK	TIN
HSS	●	●	●
SPECIFICATIONS			
Helix: 22° -24° Standard			
Point: 118° Notch			
Web: Standard			

DIAMETER INCH	DECIMAL (IN.)	FLUTE LENGTH (IN.)	OAL (IN.)	PART NUMBER	DIAMETER (IN.)	DECIMAL (IN.)	FLUTE LENGTH (IN.)	OAL (IN.)	PART NUMBER
5/16	0.3125	12	16	712-014	45/64	0.7031	12	16	712-039
21/64	0.3281	12	16	712-015	23/32	0.7188	12	16	712-040
11/32	0.3438	12	16	712-016	47/64	0.7344	12	16	712-041
23/64	0.3594	12	16	712-017	3/4	0.7500	12	16	712-042
3/8	0.3750	12	16	712-018	25/32	0.7812	12	16	712-044
25/64	0.3906	12	16	712-019	13/16	0.8125	12	16	712-046
13/32	0.4062	12	16	712-020	27/32	0.8438	12	16	712-048
27/64	0.4219	12	16	712-021	55/64	0.8594	12	16	712-049
7/16	0.4375	12	16	712-022	7/8	0.8750	12	16	712-050
29/64	0.4531	12	16	712-023	29/32	0.9062	12	16	712-052
15/32	0.4688	12	16	712-024	15/16	0.9375	12	16	712-054
31/64	0.4844	12	16	712-025	31/32	0.9688	12	16	712-056
1/2	0.5000	12	16	712-026	1	1.0000	12	16	712-059
33/64	0.5156	12	16	712-027	1-1/32	1.0313	12	16	712-060
17/32	0.5312	12	16	712-028	1-1/16	1.0625	12	16	712-061
35/64	0.5469	12	16	712-029	1-3/32	1.0938	12	18	712-062
9/16	0.5625	12	16	712-030	1-1/8	1.1250	12	18	712-063
37/64	0.5781	12	16	712-031	1-5/32	1.1562	12	18	712-064
19/32	0.5938	12	16	712-032	1-3/16	1.1875	12	18	712-065
39/64	0.6094	12	16	712-033	1-7/32	1.2188	12	18	712-066
5/8	0.6250	12	16	712-034	1-1/4	1.2500	12	18	712-067
41/64	0.6406	12	16	712-035	1-9/32	1.2812	12	18	712-068
21/32	0.6562	12	16	712-036	1-5/16	1.3125	12	18	712-069
43/64	0.6719	12	16	712-037	1-11/32	1.3438	12	18	712-070
11/16	0.6875	12	16	712-038	1-3/8	1.3750	12	18	712-071

- For coolant entry specifications, see page 18.
- Specify finish when ordering where applicable

Note : Drill bushing or starter hole recommended when drilling under 3/8" diameter



For hole concentricity we recommend using **Series 605 Spotting Drill**, see page 14.

TECHNICAL TIPS



We offer drill resharpener and reconditioning for all of our Drills. We also offer a variety of specialized drill points for specific applications. Please contact us for further information.



Visit our website at www.coolantfedtooling.com for technical information and our latest product offerings.



EXTRA LENGTH • 18" FLUTE • HIGH SPEED • STRAIGHT SHANK

SERIES 718 • COOLANT-FED



SERIES: 718

SIZES

5/16"-1"
INCH

General purpose drill works well in materials ranging from soft to medium hard. Suitable for both horizontal and vertical drilling. Notched point provides good chip formation when the proper speeds and feeds are applied. The 22° to 24° helix has constant web thickness with rolled heel providing maximum chip clearance.

MATERIAL	BRIGHT	DARK	TIN
HSS	●	●	●
SPECIFICATIONS			
Helix: 22° - 24° Standard			
Point: 118° Notch			
Web: Standard			

DIAMETER (IN.)	DECIMAL (IN.)	FLUTE LENGTH (IN.)	OAL (IN.)	PART NUMBER	DIAMETER (IN.)	DECIMAL (IN.)	FLUTE LENGTH (IN.)	OAL (IN.)	PART NUMBER
* 5/16	0.3125	18	21	718-014	39/64	0.6094	18	21	718-033
* 21/64	0.3281	18	21	718-015	5/8	0.6250	18	21	718-034
* 11/32	0.3438	18	21	718-016	41/64	0.6406	18	21	718-035
* 23/64	0.3594	18	21	718-017	21/32	0.6562	18	21	718-036
3/8	0.3750	18	21	718-018	43/64	0.6719	18	21	718-037
* 25/64	0.3906	18	21	718-019	11/16	0.6875	18	21	718-038
* 13/32	0.4062	18	21	718-020	45/64	0.7031	18	21	718-039
* 27/64	0.4219	18	21	718-021	23/32	0.7188	18	21	718-040
7/16	0.4375	18	21	718-022	47/64	0.7344	18	21	718-041
29/64	0.4531	18	21	718-023	3/4	0.7500	18	21	718-042
15/32	0.4688	18	21	718-024	25/32	0.7812	18	21	718-044
31/64	0.4844	18	21	718-025	13/16	0.8125	18	21	718-046
1/2	0.5000	18	21	718-026	27/32	0.8438	18	21	718-048
33/64	0.5156	18	21	718-027	7/8	0.8750	18	21	718-050
17/32	0.5312	18	21	718-028	29/32	0.9062	18	21	718-052
35/64	0.5469	18	21	718-029	15/16	0.9375	18	21	718-054
9/16	0.5625	18	21	718-030	31/32	0.9688	18	21	718-056
37/64	0.5781	18	21	718-031	1	1.0000	18	21	718-059
19/32	0.5938	18	21	718-032					

* **Outgoing Items**

• For coolant entry specifications, see page 18.

Note : Drill bushing or starter hole recommended when drilling under 3/8" diameter

EXTRA LENGTH • 21" FLUTE • HIGH SPEED • STRAIGHT SHANK

SERIES 721 • COOLANT-FED



SERIES: 721

SIZES

5/16"- 47/64"
INCH

General purpose drill works well in materials ranging from soft to medium hard. Suitable for both horizontal and vertical drilling. Notched point provides good chip formation when the proper speeds and feeds are applied. The 22° to 24° helix has constant web thickness with rolled heel providing maximum chip clearance.

MATERIAL	BRIGHT	DARK	TIN
HSS	●	●	●
SPECIFICATIONS			
Helix: 22° - 24° Standard			
Point: 118° Notch			
Web: Standard			

DIAMETER (IN.)	DECIMAL (IN.)	FLUTE LENGTH (IN.)	OAL (IN.)	PART NUMBER	DIAMETER (IN.)	DECIMAL (IN.)	FLUTE LENGTH (IN.)	OAL (IN.)	PART NUMBER
* 5/16	0.3125	21	24	721-014	* 9/16	0.5625	21	24	721-030
* 21/64	0.3281	21	24	721-015	* 37/64	0.5781	21	24	721-031
* 11/32	0.3438	21	24	721-016	* 19/32	0.5938	21	24	721-032
* 23/64	0.3594	21	24	721-017	* 39/64	0.6094	21	24	721-033
* 3/8	0.3750	21	24	721-018	* 5/8	0.6250	21	24	721-034
* 25/64	0.3906	21	24	721-019	* 41/64	0.6406	21	24	721-035
* 13/32	0.4062	21	24	721-020	* 21/32	0.6562	21	24	721-036
* 27/64	0.4219	21	24	721-021	* 43/64	0.6719	21	24	721-037
* 7/16	0.4375	21	24	721-022	* 11/16	0.6875	21	24	721-038
* 29/64	0.4531	21	24	721-023	* 45/64	0.7031	21	24	721-039
* 15/32	0.4688	21	24	721-024	* 23/32	0.7188	21	24	721-040
* 31/64	0.4844	21	24	721-025	* 47/64	0.7344	21	24	721-041

* **Outgoing Items**

• For coolant entry specifications, see page 18.

• Specify finish when ordering where applicable

Note : Drill bushing or starter hole recommended when drilling under 3/8" diameter

* **Outgoing Items**



For hole concentricity we recommend using **Series 605 Spotting Drill**, see page 14.



STUB LENGTH • CARBIDE TIPPED • PARABOLIC • STRAIGHT SHANK

SERIES 903 • COOLANT-FED



SERIES: 903
SIZES
5/16"-1" INCH

Parabolic style carbide tipped drill that works well in non-ferrous materials and some steel and stainless steel applications. Helical point gives it a self centering start. Carbide is C2 micrograin for top performance. Constant web with rolled heel provides maximum chip clearance.

MATERIAL	BRIGHT	DARK	TIN
C2 MICROGRAIN	●		●
SPECIFICATIONS			
Helix: 22° -24° Parabolic			
Point: 135° Helical			
Web: Standard			

DIAMETER (IN.)	DECIMAL (IN.)	FLUTE LENGTH (IN.)	OAL (IN.)	PART NUMBER
5/16	0.3125	2-1/2	4-1/2	903-013
21/64	0.3281	2-1/2	4-1/2	903-014
11/32	0.3438	2-1/2	4-1/2	903-015
23/64	0.3594	2-1/2	4-1/2	903-016
3/8	0.3750	2-1/2	4-1/2	903-017
25/64	0.3906	3	5	903-018
13/32	0.4062	3	5	903-019
27/64	0.4219	3	5	903-020
7/16	0.4375	3	5	903-021
29/64	0.4531	3-1/2	5-1/2	903-022
15/32	0.4688	3-1/2	5-1/2	903-023
31/64	0.4844	3-1/2	5-1/2	903-024
1/2	0.5000	3-1/2	5-1/2	903-025
33/64	0.5156	4	6	903-026

DIAMETER (IN.)	DECIMAL (IN.)	FLUTE LENGTH (IN.)	OAL (IN.)	PART NUMBER
17/32	0.5312	4	6	903-027
35/64	0.5469	4	6	903-028
9/16	0.5625	4	6	903-029
37/64	0.5781	4-1/2	6-1/2	903-030
19/32	0.5938	4-1/2	6-1/2	903-031
39/64	0.6094	4-1/2	6-1/2	903-032
5/8	0.6250	4-1/2	6-1/2	903-033
* 41/64	0.6406	5	7	903-034
* 21/32	0.6562	5	7	903-035
* 47/64	0.7344	5	7	903-040
* 3/4	0.7500	5	7	903-041
* 13/16	0.8125	5	7	903-045
* 15/16	0.9375	5	7	903-053
* 1	1.0000	5	7	903-057

*** Outgoing Items**

• For coolant entry specifications, see page 18.

STUB • TAPER LENGTH • EXTRA LENGTH • METRIC • CARBIDE TIP • STRAIGHT SHANK

SERIES: M903
SERIES: M905
SERIES: M908
SIZES
9.5 - 24.5 MM



Carbide tipped drill designed for non-ferrous materials such as aluminum and cast iron. Can be used in other materials such as steel but in steel applications performance may not be consistent. Double angle point increases the margin life. Carbide is C2 micrograin for top performance. Constant web with rolled heel provides maximum chip clearance. For coolant entry specifications, see page 18.

MATERIAL	BRIGHT	DARK	TIN
C2 MICROGRAIN	●		●
SPECIFICATIONS			
Helix: 22° -24° Standard			
Point: 118°/90° Double Angle			
Web: Standard			

SERIES M905 • TAPER LENGTH • METRIC

DIAMETER (MM)	DECIMAL (IN.)	FLUTE LENGTH (IN.)	OAL (IN.)	PART NUMBER
10.2	0.4016	4-3/8	7	M905-115
10.5	0.4134	4-5/8	7-1/4	M905-125
12.2	0.4803	5	7-3/4	M905-135
13.8	0.5433	5-3/8	8-1/4	M905-155
*14.2	0.5591	5-3/8	8-1/4	M905-165
*17.0	0.6693	6	9-1/4	M905-175
*19.0	0.7480	6-3/8	9-3/4	M905-185
*24.0	0.9449	7-1/8	10-7/8	M905-195

*** Outgoing Items**

SERIES M903 • STUB LENGTH • METRIC

DIAMETER (MM)	DECIMAL (IN.)	FLUTE LENGTH (IN.)	OAL (IN.)	PART NUMBER
13.8	0.5433	4-3/8	7-1/4	M903-110
16.7	0.6575	3-3/4	6-1/2	M903-115

SERIES M908 • EXTRA LENGTH • METRIC

DIAMETER (MM)	DECIMAL (IN.)	FLUTE LENGTH (MM)	OAL (MM)	PART NUMBER
9.5	0.3740	8	10-1/2	M908-105
9.5	0.3740	9-1/2	11-1/2	M908-110
9.5	0.3740	12-1/2	14-1/2	M908-115
11.5	0.4528	8	11	M908-120
12.2	0.4803	7	10-1/2	M908-125
13.8	0.5433	8-1/2	11-1/2	M908-130
16.0	0.6299	9-1/4	12	M908-135
16.8	0.6614	9	12	M908-140
17.0	0.6693	9-1/2	12-3/4	M908-145
19.0	0.7480	9	12	M908-150
24.5	0.9646	9	12	M908-155

• Specify finish when ordering where applicable



TAPER LENGTH • CARBIDE TIP • STRAIGHT SHANK

SERIES 905 • COOLANT-FED



SERIES: 905

SIZES

5/16" - 1"
INCH

Carbide tipped drill designed for non-ferrous materials such as aluminum and cast iron. Can be used in other materials such as steel but in steel applications performance may not be consistent. Double angle point increases the margin life. Carbide is C2 micrograin for top performance. Constant web with rolled heel provides maximum chip clearance.

MATERIAL	BRIGHT	DARK	TIN
C2 MICROGRAIN	●		●
SPECIFICATIONS			
Helix: 22° -24° Standard			
Point: 118°/90° Double Angle			
Web: Standard			

DIAMETER INCH	DECIMAL (IN.)	FLUTE LENGTH (IN.)	OAL (IN.)	PART NUMBER
5/16	0.3125	3-7/8	6-1/4	905-013
21/64	0.3281	4-1/8	6-1/2	905-014
11/32	0.3438	4-1/8	6-1/2	905-015
23/64	0.3594	4-1/4	6-3/4	905-016
3/8	0.3750	4-1/4	6-3/4	905-017
25/64	0.3906	4-3/8	7	905-018
13/32	0.4062	4-3/8	7	905-019
27/64	0.4219	4-5/8	7-1/4	905-020
7/16	0.4375	4-5/8	7-1/4	905-021
29/64	0.4531	4-7/8	7-1/2	905-022
15/32	0.4688	4-7/8	7-1/2	905-023
31/64	0.4844	5	7-3/4	905-024
1/2	0.5000	5	7-3/4	905-025
33/64	0.5156	5-1/4	8	905-026
17/32	0.5312	5-1/4	8	905-027
35/64	0.5469	5-3/8	8-1/4	905-028
9/16	0.5625	5-3/8	8-1/4	905-029
37/64	0.5781	5-5/8	8-1/2	905-030
19/32	0.5938	5-5/8	8-1/2	905-031
39/64	0.6094	5-3/4	8-3/4	905-032
5/8	0.6250	5-3/4	8-3/4	905-033
41/64	0.6406	5-7/8	9	905-034
21/32	0.6562	5-7/8	9	905-035

DIAMETER (IN.)	DECIMAL (IN.)	FLUTE LENGTH (IN.)	OAL (IN.)	PART NUMBER
43/64	0.6719	6	9-1/4	905-036
11/16	0.6875	6	9-1/4	905-037
45/64	0.7031	6-3/16	9-1/2	905-038
23/32	0.7188	6-3/16	9-1/2	905-039
47/64	0.7344	6-3/8	9-3/4	905-040
3/4	0.7500	6-3/8	9-3/4	905-041
*49/64	0.7656	6-1/2	9-7/8	905-042
*25/32	0.7812	6-1/2	9-7/8	905-043
*51/64	0.7969	6-5/8	10	905-044
*13/16	0.8125	6-5/8	10	905-045
*53/64	0.8281	6-3/4	10-1/4	905-046
*27/32	0.8438	6-3/4	10-1/4	905-047
*55/64	0.8594	7	10-1/2	905-048
*7/8	0.8750	7	10-1/2	905-049
* 57/64	0.8906	7	10-5/8	905-050
* 29/32	0.9062	7	10-5/8	905-051
* 1	1.0000	7-3/16	11	905-057

* Outgoing Items

- For coolant entry specifications, see page 18.

EXTRA LENGTH • CARBIDE TIP • 9" FLUTE • STRAIGHT SHANK

SERIES 908 • COOLANT-FED



SERIES: 908

SIZES

5/8" - 1"
INCH

Carbide tipped drill designed for non-ferrous materials such as aluminum and cast iron. Can be used in other materials such as steel but in steel applications performance may not be consistent. Double angle point increases the margin life. Carbide is C2 micrograin for top performance. Constant web with rolled heel provides maximum chip clearance.

MATERIAL	BRIGHT	DARK	TIN
C2 MICROGRAIN	●		●
SPECIFICATIONS			
Helix: 22° -24° Standard			
Point: 118°/90° Double Angle			
Web: Standard			

DIAMETER INCH	DECIMAL (IN.)	FLUTE LENGTH (IN.)	OAL (IN.)	PART NUMBER
* 5/8	0.6250	9	12	908-034
* 41/64	0.6406	9	12	908-035
* 21/32	0.6562	9	12	908-036
* 47/64	0.7344	9	12	908-041
* 3/4	0.7500	9	12	908-042

* Outgoing Items

DIAMETER (IN.)	DECIMAL (IN.)	FLUTE LENGTH (IN.)	OAL (IN.)	PART NUMBER
* 25/32	0.7812	9	12	908-044
* 13/16	0.8125	9	12	908-046
* 7/8	0.8750	9	12	908-050
* 61/64	0.9531	9	12	908-055
* 1	1.0000	9	12	908-058

* Outgoing Items

- For coolant entry specifications, see page 18.
- Specify finish when ordering where applicable



STANDARD LENGTH • HIGH SPEED • TAPER SHANK

SERIES 802 • COOLANT-FED



SERIES: 802

SIZES

3/16" - 2" INCH

General purpose drill works well in most all materials. Suitable for both horizontal and vertical drilling. Taper shank allows the tool to quickly adapt to drill presses or special drilling machines. Notched point provides good chip formation when the proper speeds and feeds are applied. Constant web thickness with rolled heel provides maximum chip clearance.

MATERIAL	BRIGHT	DARK	TIN
HSS	●	●	●

SPECIFICATIONS

Helix: 32° - 34° Spiral
Point: 118° Notch
Web: Standard

DIAMETER INCH	DECIMAL (IN.)	FLUTE LGTH. (IN.)	OAL (IN.)	M.T.	PART NUMBER
3/16	0.1875	2-1/2	5-3/4	1	802-101
13/64	0.2031	2-3/4	6	1	802-102
7/32	0.2188	2-3/4	6	1	802-103
15/64	0.2344	2-7/8	6-1/8	1	802-104
1/4	0.2500	3-3/8	6-5/8	1	802-001
17/64	0.2656	3-5/8	6-7/8	1	802-002
9/32	0.2812	3-5/8	6-7/8	1	802-003
19/64	0.2969	3-7/8	7-1/8	1	802-004
5/16	0.3125	3-7/8	7-1/8	1	802-005
5/16	0.3125	3-7/8	7-3/4	2	802-005A
21/64	0.3281	4-1/8	8	2	802-006
21/64	0.3281	4-1/8	8-3/4	3	802-006A
11/32	0.3438	4-1/8	8	2	802-007
11/32	0.3438	4-1/8	8-3/4	3	802-007A
23/64	0.3594	4-1/4	8-1/8	2	802-008
23/64	0.3594	4-1/4	8-7/8	3	802-008A
3/8	0.3750	4-1/4	8-1/8	2	802-009
3/8	0.3750	4-1/4	8-7/8	3	802-009A
25/64	0.3906	4-3/8	8-1/4	2	802-010
25/64	0.3906	4-3/8	9	3	802-010A
13/32	0.4062	4-3/8	8-1/4	2	802-011
13/32	0.4062	4-3/8	9	3	802-011A
27/64	0.4219	4-5/8	8-1/2	2	802-012
27/64	0.4219	4-5/8	9-1/4	3	802-012A
7/16	0.4375	4-5/8	8-1/2	2	802-013
7/16	0.4375	4-5/8	9-1/4	3	802-013A
29/64	0.4531	4-7/8	8-3/4	2	802-014
29/64	0.4531	4-7/8	9-1/2	3	802-014A
15/32	0.4688	4-7/8	8-3/4	2	802-015
15/32	0.4688	4-7/8	9-1/2	3	802-015A
31/64	0.4844	4-3/8	9	2	802-016
31/64	0.4844	4-3/8	9	3	802-016A
1/2	0.5000	4-3/8	9	3	802-017
1/2	0.5000	4-3/8	9	2	802-017A
33/64	0.5156	4-5/8	9-1/4	3	802-018
33/64	0.5156	4-5/8	8-5/8	2	802-018A
17/32	0.5312	4-5/8	9-1/4	3	802-019
35/64	0.5469	4-7/8	9-1/2	3	802-020
9/16	0.5625	4-7/8	9-1/2	3	802-021
37/64	0.5781	4-7/8	9-1/2	3	802-022
19/32	0.5938	4-7/8	9-1/2	3	802-023
39/64	0.6094	4-7/8	9-1/2	3	802-024
5/8	0.6250	4-7/8	9-1/2	3	802-025
41/64	0.6406	5-1/8	9-3/4	3	802-026
21/32	0.6562	5-1/8	9-3/4	3	802-027
43/64	0.6719	5-3/8	10	3	802-028
11/16	0.6875	5-3/8	10	3	802-029
45/64	0.7031	5-3/8	10-1/4	3	802-030
23/32	0.7188	5-5/8	10-1/4	3	802-031
47/64	0.7344	5-7/8	10-1/2	3	802-032
*47/64	0.7344	5-7/8	9-5/8	2	802-032A
3/4	0.7500	5-7/8	10-1/2	3	802-033
49/64	0.7656	6	10-5/8	3	802-034
25/32	0.7812	6	10-5/8	3	802-035
51/64	0.7969	6-1/8	10-3/4	3	802-036
13/16	0.8125	6-1/8	10-3/4	3	802-037
53/64	0.8281	6-1/8	10-3/4	3	802-137
27/32	0.8438	6-1/8	10-3/4	3	802-138
55/64	0.8594	6-1/8	10-3/4	3	802-139

* Outgoing Items

- For coolant entry specifications, see page 18.
- Specify finish when ordering where applicable

DIAMETER INCH	DECIMAL (IN.)	FLUTE LGTH. (IN.)	OAL (IN.)	M.T.	PART NUMBER
7/8	0.8750	6-1/8	10-3/4	3	802-038
57/64	0.8906	6-1/8	10-3/4	3	802-039
29/32	0.9062	6-1/8	10-3/4	3	802-040
59/64	0.9219	6-1/8	10-3/4	3	802-041
15/16	0.9375	6-1/8	10-3/4	3	802-042
61/64	0.9531	6-3/8	11	3	802-043
31/32	0.9688	6-3/8	11	3	802-044
63/64	0.9844	6-3/8	11	3	802-045
1	1.0000	6-3/8	11	3	802-046
1-1/32	1.0313	6-1/2	11-1/8	3	802-047
1-1/16	1.0625	6-5/8	11-1/4	3	802-048
1-1/16	1.0625	6-5/8	12-1/4	4	802-048A
1-3/32	1.0938	6-7/8	12-1/2	4	802-049
1-1/8	1.1250	7-1/8	12-3/4	4	802-050
1-5/32	1.1562	7-1/4	12-7/8	4	802-051
1-3/16	1.1875	7-3/8	13	4	802-052
1-7/32	1.2188	7-1/2	13-1/8	4	802-053
1-1/4	1.2500	7-7/8	13-1/2	4	802-054
1-9/32	1.2812	8-1/2	14-1/8	4	802-055
1-5/16	1.3125	8-5/8	14-1/4	4	802-056
1-11/32	1.3438	8-3/4	14-3/8	4	802-057
1-3/8	1.3750	8-7/8	14-1/2	4	802-058
1-13/32	1.4062	9	14-5/8	4	802-059
1-7/16	1.4375	9-1/8	14-3/4	4	802-060
1-15/32	1.4688	9-1/4	14-7/8	4	802-061
1-1/2	1.5000	9-3/8	15	4	802-062
1-9/16	1.5625	9-5/8	15-1/4	4	802-063
1-5/8	1.6250	10	15-5/8	4	802-064
1-11/16	1.6875	10-1/8	15-3/4	4	802-065
1-3/4	1.7500	10-1/8	16	4	802-066
1-13/16	1.8125	10-1/8	17-1/8	5	802-067
1-7/8	1.8750	10-3/8	17-3/8	5	802-068
1-15/16	1.9375	10-3/8	17-3/8	5	802-069
2	2.0000	10-3/8	17-3/8	5	802-070

LARGE DIAMETER

DIAMETER INCH	DECIMAL (IN.)	FLUTE LGTH. (IN.)	OAL (IN.)	M.T.	PART NUMBER
* 2-1/32	2.0312	10-1/4	17-3/8	5	802-090
* 2-1/16	2.0625	10-1/4	17-3/8	5	802-091
* 2-1/8	2.1250	10-1/4	17-3/8	5	802-092
* 2-3/16	2.1875	10-1/4	17-3/8	5	802-093
* 2-1/4	1.2500	10-1/8	17-3/8	5	802-094
* 2-5/16	2.3125	10-1/8	17-3/8	5	802-095
* 2-3/8	2.3750	10-1/8	17-3/8	5	802-096
* 2-7/16	2.4375	11-1/4	18-3/4	5	802-097
* 2-1/2	2.5000	11-1/4	18-3/4	5	802-098
* 2-9/16	2.5625	11-7/8	19-1/2	5	802-099
* 2-5/8	2.6250	11-7/8	19-1/2	5	802-100
* 2-11/16	2.6875	12-3/4	20-3/8	5	802-201
* 2-3/4	2.7500	12-3/4	20-3/8	5	802-202
* 2-13/16	2.8125	13-3/8	21-1/8	5	802-203
* 2-7/8	2.8750	13-3/8	21-1/8	5	802-204
* 2-15/16	2.9375	14	21-3/4	5	802-205
* 3	3.0000	14	21-3/4	5	802-206
* 3-1/16	3.0625	14-5/8	24-1/2	5	802-207
* 3-1/8	3.1250	14-5/8	24-1/2	5	802-208

* Outgoing Items



EXTRA LENGTH • 7" FLUTE • HIGH SPEED • TAPER SHANK

SERIES 807 • COOLANT-FED



SERIES: 807

SIZES

1/4" - 3/4"
INCH

General purpose drill works well in most all materials. Suitable for both horizontal and vertical drilling. Taper shank allows the tool to quickly adapt to drill presses or special drilling machines. Notched point provides good chip formation when the proper speeds and feeds are applied. Constant web thickness with rolled heel provides maximum chip clearance.

MATERIAL	BRIGHT	DARK	TIN
HSS	●	●	●
SPECIFICATIONS			
Helix: 32° -34° Spiral			
Point: 118° Notch			
Web: Standard			

DIAMETER INCH	DECIMAL (IN.)	FLUTE LGTH. (IN.)	OAL (IN.)	M.T.	PART NUMBER
1/4	0.2500	7	10-7/8	2	807-001
1/4	0.2500	7	11-5/8	3	807-001A
17/64	0.2656	7	10-7/8	2	807-002
17/64	0.2656	7	11-5/8	3	807-002A
9/32	0.2812	7	10-7/8	2	807-003
9/32	0.2812	7	11-5/8	3	807-003A
19/64	0.2969	7	10-7/8	2	807-004
19/64	0.2969	7	11-5/8	3	807-004A
5/16	0.3125	7	10-7/8	2	807-005
5/16	0.3125	7	11-5/8	3	807-005A
21/64	0.3281	7	10-7/8	2	807-006
21/64	0.3281	7	11-5/8	3	807-006A
11/32	0.3438	7	10-7/8	2	807-506
11/32	0.3438	7	11-5/8	3	807-506A
23/64	0.3594	7	10-7/8	2	807-007
23/64	0.3594	7	11-5/8	3	807-007A
3/8	0.3750	7	10-7/8	2	807-008
3/8	0.3750	7	11-5/8	3	807-008A
25/64	0.3906	7	10-7/8	2	807-009
25/64	0.3906	7	11-5/8	3	807-009A
13/32	0.4062	7	10-7/8	2	807-010
13/32	0.4062	7	11-5/8	3	807-010A
27/64	0.4219	7	10-7/8	2	807-011
27/64	0.4219	7	11-5/8	3	807-011A
7/16	0.4375	7	10-7/8	2	807-012
7/16	0.4375	7	11-5/8	3	807-012A

DIAMETER INCH	DECIMAL (IN.)	FLUTE LGTH. (IN.)	OAL (IN.)	M.T.	PART NUMBER
29/64	0.4531	7	10-7/8	2	807-013
29/64	0.4531	7	11-5/8	3	807-013A
15/32	0.4688	7	10-7/8	2	807-014
15/32	0.4688	7	11-5/8	3	807-014A
31/64	0.4844	7	11-5/8	3	807-015
1/2	0.5000	7	11-5/8	3	807-016
33/64	0.5156	7	11-5/8	3	807-017
17/32	0.5312	7	11-5/8	3	807-018
35/64	0.5469	7	11-5/8	3	807-019
9/16	0.5625	7	11-5/8	3	807-020
37/64	0.5781	7	11-5/8	3	807-021
19/32	0.5938	7	11-5/8	3	807-022
39/64	0.6094	7	11-5/8	3	807-023
5/8	0.6250	7	11-5/8	3	807-024
41/64	0.6406	7	11-5/8	3	807-025
21/32	0.6562	7	11-5/8	3	807-026
43/64	0.6719	7	11-5/8	3	807-027
11/16	0.6875	7	11-5/8	3	807-028
45/64	0.7031	7	11-5/8	3	807-029
23/32	0.7188	7	11-5/8	3	807-030
*23/32	0.7188	7	10-7/8	2	807-030A
47/64	0.7344	7	11-5/8	3	807-031
3/4	0.7500	7	11-5/8	3	807-032

*** Outgoing Items**

- For coolant entry specifications, see page 18.
- Specify finish when ordering where applicable

Note : Drill bushing or starter hole recommended when drilling under 3/8 diameter

TECHNICAL TIPS



We offer drill resharpening and reconditioning for all of our Drills. We also offer a variety of specialized drill points for specific applications. Please contact us for further information.



Visit our website at www.coolantfedtooling.com for technical information and our latest product offerings.



EXTRA LENGTH • 9" FLUTE • HIGH SPEED • TAPER SHANK

SERIES 809 • COOLANT-FED



SERIES: 809

SIZES

25/64" - 1-1/16"
INCH

General purpose drill works well in most all materials. Suitable for both horizontal and vertical drilling. Taper shank allows the tool to quickly adapt to drill presses or special drilling machines. Notched point provides good chip formation when the proper speeds and feeds are applied. Constant web thickness with rolled heel provides maximum chip clearance.

MATERIAL	BRIGHT	DARK	TIN
	HSS	●	●
SPECIFICATIONS			
Helix: 32° -34° Spiral			
Point: 118° Notch			
Web: Standard			

DIAMETER (IN.)	DECIMAL (IN.)	FLUTE LGTH. (IN.)	OAL (IN.)	M.T.	PART NUMBER	DIAMETER (IN.)	DECIMAL (IN.)	FLUTE LGTH (IN.)	OAL (IN.)	M.T.	PART NUMBER
25/64	0.3906	9	12-7/8	2	809-009	5/8	0.6250	9	13-5/8	3	809-024
25/64	0.3906	9	13-5/8	3	809-009A	41/64	0.6406	9	13-5/8	3	809-025
13/32	0.4062	9	12-7/8	2	809-010	21/32	0.6562	9	13-5/8	3	809-026
13/32	0.4062	9	13-5/8	3	809-010A	43/64	0.6719	9	13-5/8	3	809-027
27/64	0.4219	9	12-7/8	2	809-011	11/16	0.6875	9	13-5/8	3	809-028
27/64	0.4219	9	13-5/8	3	809-011A	45/64	0.7031	9	13-5/8	3	809-029
7/16	0.4375	9	12-7/8	2	809-012	23/32	0.7188	9	13-5/8	3	809-030
7/16	0.4375	9	13-5/8	3	809-012A	47/64	0.7344	9	13-5/8	3	809-031
29/64	0.4531	9	12-7/8	2	809-013	3/4	0.7500	9	13-5/8	3	809-032
29/64	0.4531	9	13-5/8	3	809-013A	49/64	0.7656	9	13-5/8	3	809-033
15/32	0.4688	9	12-7/8	2	809-014	25/32	0.7812	9	13-5/8	3	809-034
15/32	0.4688	9	13-5/8	3	809-014A	13/16	0.8125	9	13-5/8	3	809-035
31/64	0.4844	9	13-5/8	3	809-015	27/32	0.8438	9	13-5/8	3	809-036
1/2	0.5000	9	13-5/8	3	809-016	7/8	0.8750	9	13-5/8	3	809-037
33/64	0.5156	9	13-5/8	3	809-017	29/32	0.9062	9	13-5/8	3	809-038
17/32	0.5312	9	13-5/8	3	809-018	15/16	0.9375	9	13-5/8	3	809-039
35/64	0.5469	9	13-5/8	3	809-019	31/32	0.9688	9	13-5/8	3	809-040
9/16	0.5625	9	13-5/8	3	809-020	1	1.0000	9	13-5/8	3	809-041
37/64	0.5781	9	13-5/8	3	809-021	1-1/32	1.0313	9	13-5/8	3	809-042
19/32	0.5938	9	13-5/8	3	809-022	1-1/16	1.0625	9	13-5/8	3	809-043
39/64	0.6094	9	13-5/8	3	809-023						

- For coolant entry specifications, see page 18.
- Specify finish when ordering where applicable



For hole concentricity we recommend using **Series 605 Spotting Drill**, see page 14.

COMMON MACHINING EQUATIONS

SFM =	RPM X Dia. / 3.82
RPM =	3.82 x SFM / Dia.
IPM =	IPT x No. Teeth x RPM
IPT =	IPM / (No. Teeth x RPM)
IPR =	IPM / RPM

- SFM:** SURFACE FEET PER MINUTE
- RPM:** REVOLUTIONS PER MINUTE
- IPM:** INCHES PER MINUTE
- IPT:** INCHES PER TOOTH
- IPR:** INCHES PER REVOLUTION



Visit our website at www.coolantfedtooling.com for technical information and our latest product offerings.



EXTRA LENGTH • 10" FLUTE • HIGH SPEED • TAPER SHANK

SERIES 810 • COOLANT-FED



SERIES: 810

SIZES

25/64" - 1-1/4"
INCH

General purpose drill works well in most all materials. Suitable for both horizontal and vertical drilling. Taper shank allows the tool to quickly adapt to drill presses or special drilling machines. Notched point provides good chip formation when the proper speeds and feeds are applied. Constant web thickness with rolled heel provides maximum chip clearance.

MATERIAL	BRIGHT	DARK	TiN
HSS	●	●	●
SPECIFICATIONS			
Helix: 32° -34° Spiral			
Point: 118° Notch			
Web: Standard			

DIAMETER INCH	DECIMAL (IN.)	FLUTE LGTH (IN.)	OAL (IN.)	M.T.	PART NUMBER	DIAMETER INCH	DECIMAL (IN.)	FLUTE LGTH (IN.)	OAL (IN.)	M.T.	PART NUMBER
25/64	0.3906	10	13-7/8	2	810-009	43/64	0.6719	10	14-5/8	3	810-027
25/64	0.3906	10	14-5/8	3	810-009A	11/16	0.6875	10	14-5/8	3	810-028
13/32	0.4062	10	13-7/8	2	810-010	45/64	0.7031	10	14-5/8	3	810-029
13/32	0.4062	10	14-5/8	3	810-010A	23/32	0.7188	10	14-5/8	3	810-030
27/64	0.4219	10	13-7/8	2	810-011	47/64	0.7344	10	14-5/8	3	810-031
27/64	0.4219	10	14-5/8	3	810-011A	3/4	0.7500	10	14-5/8	3	810-032
7/16	0.4375	10	13-7/8	2	810-012	49/64	0.7656	10	14-5/8	3	810-033
7/16	0.4375	10	14-5/8	3	810-012A	25/32	0.7812	10	14-5/8	3	810-034
29/64	0.4531	10	13-7/8	2	810-013	13/16	0.7968	10	14-5/8	3	810-035
29/64	0.4531	10	14-5/8	3	810-013A	27/32	0.8438	10	14-5/8	3	810-036
15/32	0.4688	10	13-7/8	2	810-014	7/8	0.8750	10	14-5/8	3	810-037
15/32	0.4688	10	14-5/8	3	810-014A	29/32	0.9062	10	14-5/8	3	810-038
31/64	0.4844	10	14-5/8	3	810-015	15/16	0.9375	10	14-5/8	3	810-039
1/2	0.5000	10	14-5/8	3	810-016	31/32	0.9688	10	14-5/8	3	810-040
33/64	0.5156	10	14-5/8	3	810-017	1	1.0000	10	14-5/8	3	810-041
17/32	0.5312	10	14-5/8	3	810-018	1-1/32	1.0313	10	14-5/8	3	810-042
35/64	0.5469	10	14-5/8	3	810-019	1-1/16	1.0625	10	14-5/8	3	810-043
9/16	0.5625	10	14-5/8	3	810-020	1-1/16	1.0625	10	15-7/8	4	810-043A
37/64	0.5781	10	14-5/8	3	810-021	1-3/32	1.0938	10	15-7/8	4	810-044
19/32	0.5938	10	14-5/8	3	810-022	1-1/8	1.1250	10	15-7/8	4	810-045
39/64	0.6094	10	14-5/8	3	810-023	1-5/32	1.1562	10	15-7/8	4	810-046
5/8	0.6250	10	14-5/8	3	810-024	1-3/16	1.1875	10	15-7/8	4	810-047
41/64	0.6406	10	14-5/8	3	810-025	1-7/32	1.2188	10	15-7/8	4	810-048
21/32	0.6562	10	14-5/8	3	810-026	1-1/4	1.2500	10	15-7/8	4	810-049

- For coolant entry specifications, see page 18.
- Specify finish when ordering where applicable



For hole concentricity we recommend using **Series 605 Spotting Drill**, see page 14.

TECHNICAL TIPS

REQUIRED FOR SPEED AND FEED INFORMATION:

- Material being drilled
- Rockwell (Rc) or Brinell (Bhn) Hardness
- Diameter and Depth of hole
- Vertical or Horizontal Orientation
- Coolant Pressure of the Machine Tools Coolant Pump
- Type of Tool Holders being used (i.e., Collet Chuck)



Visit our website at www.coolantfedtooling.com for technical information and our latest product offerings.



EXTRA LENGTH • 12" FLUTE • HIGH SPEED • TAPER SHANK

SERIES 812 • COOLANT-FED



SERIES: 812

SIZES

25/64" - 2"
INCH

General purpose drill works well in most all materials. Suitable for both horizontal and vertical drilling. Taper shank allows the tool to quickly adapt to drill presses or special drilling machines. Notched point provides good chip formation when the proper speeds and feeds are applied. Constant web thickness with rolled heel provides maximum chip clearance.

MATERIAL	BRIGHT	DARK	TIN
HSS	●	●	●
SPECIFICATIONS			
Helix: 32° -34° Spiral			
Point: 118° Notch			
Web: Standard			

DIAMETER (IN.)	DECIMAL (IN.)	FLUTE LGTH. (IN.)	OAL (IN.)	M.T.	PART NUMBER	DIAMETER (IN.)	DECIMAL (IN.)	FLUTE LGTH. (IN.)	OAL (IN.)	M.T.	PART NUMBER
25/64	0.3906	12	15-7/8	2	812-009	13/16	0.8125	12	16-5/8	3	812-035
25/64	0.3906	12	16-5/8	3	812-009A	27/32	0.8438	12	16-5/8	3	812-036
13/32	0.4062	12	15-7/8	2	812-010	7/8	0.8750	12	16-5/8	3	812-037
13/32	0.4062	12	16-5/8	3	812-010A	29/32	0.9062	12	16-5/8	3	812-038
27/64	0.4219	12	15-7/8	2	812-011	15/16	0.9375	12	16-5/8	3	812-039
27/64	0.4219	12	16-5/8	3	812-011A	31/32	0.9688	12	16-5/8	3	812-040
7/16	0.4375	12	15-7/8	2	812-012	1	1.0000	12	16-5/8	3	812-041
7/16	0.4375	12	16-5/8	3	812-012A	1-1/32	1.0313	12	16-5/8	3	812-042
29/64	0.4531	12	15-7/8	2	812-013	1-1/16	1.0625	12	16-5/8	3	812-043
29/64	0.4531	12	16-5/8	3	812-013A	1-3/32	1.0938	12	16-5/8	4	812-044
15/32	0.4688	12	15-7/8	2	812-014	1-1/8	1.1250	12	17-7/8	4	812-045
15/32	0.4688	12	16-5/8	3	812-014A	1-5/32	1.1562	12	17-7/8	4	812-046
31/64	0.4844	12	16-5/8	3	812-015	1-3/16	1.1875	12	17-7/8	4	812-047
1/2	0.5000	12	16-5/8	3	812-016	1-7/32	1.2188	12	17-7/8	4	812-048
33/64	0.5156	12	16-5/8	3	812-017	1-1/4	1.2500	12	17-7/8	4	812-049
17/32	0.5312	12	16-5/8	3	812-018	1-9/32	1.2812	12	17-7/8	4	812-050
35/64	0.5469	12	16-5/8	3	812-019	1-5/16	1.3125	12	17-7/8	4	812-051
9/16	0.5625	12	16-5/8	3	812-020	1-11/32	1.3438	12	17-7/8	4	812-052
37/64	0.5781	12	16-5/8	3	812-021	1-3/8	1.3750	12	17-7/8	4	812-053
19/32	0.5938	12	16-5/8	3	812-022	1-13/32	1.4062	12	17-7/8	4	812-054
39/64	0.6094	12	16-5/8	3	812-023	1-7/16	1.4375	12	17-7/8	4	812-055
5/8	0.6250	12	16-5/8	3	812-024	1-15/32	1.4687	12	17-7/8	4	812-056
41/64	0.6406	12	16-5/8	3	812-025	1-1/2	1.5000	12	17-7/8	4	812-057
21/32	0.6562	12	16-5/8	3	812-026	1-9/16	1.5625	12	19	4	812-058
43/64	0.6719	12	16-5/8	3	812-027	1-5/8	1.6250	12	19	4	812-059
11/16	0.6875	12	16-5/8	3	812-028	1-11/16	1.6875	12	19	4	812-060
45/64	0.7031	12	16-5/8	3	812-029	1-3/4	1.7500	12	19	4	812-061
23/32	0.7188	12	16-5/8	3	812-030	1-13/16	1.8125	12	19	5	812-085
47/64	0.7344	12	16-5/8	3	812-031	1-7/8	1.8750	12	19	5	812-086
3/4	0.7500	12	16-5/8	3	812-032	1-15/16	1.9375	12	19	5	812-087
49/64	0.7656	12	16-5/8	3	812-033	2	2.0000	12	19	5	812-062
25/32	0.7812	12	16-5/8	3	812-034						

- For coolant entry specifications, see page 18.
- Specify finish when ordering where applicable.



For hole concentricity we recommend using **Series 605 Spotting Drill**, see page 14.



EXTRA LENGTH • 14" FLUTE • HIGH SPEED • TAPER SHANK

SERIES 814 • COOLANT-FED



MATERIAL	BRIGHT	DARK	TIN
HSS	●	●	●
SPECIFICATIONS			
Helix: 32° -34° Spiral			
Point: 118° Notch			
Web: Standard			

SERIES: 814
SIZES
27/64" - 2" INCH

General purpose drill works well in most all materials. Suitable for both horizontal and vertical drilling. Taper shank allows the tool to quickly adapt to drill presses or special drilling machines. Notched point provides good chip formation when the proper speeds and feeds are applied. Constant web thickness with rolled heel provides maximum chip clearance.

DIAMETER INCH	DECIMAL (IN.)	FLUTE LGTH. (IN.)	OAL (IN.)	M.T.	PART NUMBER	DIAMETER (IN.)	DECIMAL (IN.)	FLUTE LGTH. (IN.)	OAL (IN.)	M.T.	PART NUMBER
27/64	0.4219	14	17-7/8	2	814-011	7/8	0.8750	14	18-5/8	3	814-037
7/16	0.4375	14	17-7/8	2	814-012	29/32	0.9062	14	18-5/8	3	814-038
7/16	0.4375	14	18-5/8	3	814-012A	15/16	0.9375	14	18-5/8	3	814-039
29/64	0.4531	14	17-7/8	2	814-013	31/32	0.9688	14	18-5/8	3	814-040
29/64	0.4531	14	18-5/8	3	814-013A	1	1.0000	14	18-5/8	3	814-041
15/32	0.4688	14	17-7/8	2	814-014	1-1/32	1.0313	14	18-5/8	3	814-042
15/32	0.4688	14	18-5/8	3	814-014A	1-1/16	1.0625	14	18-5/8	3	814-043
31/64	0.4844	14	18-5/8	3	814-015	1-3/32	1.0938	14	19-7/8	4	814-044
1/2	0.5000	14	18-5/8	3	814-016	1-1/8	1.1250	14	19-7/8	4	814-045
33/64	0.5156	14	18-5/8	3	814-017	1-5/32	1.1562	14	19-7/8	4	814-046
17/32	0.5312	14	18-5/8	3	814-018	1-3/16	1.1875	14	19-7/8	4	814-047
35/64	0.5469	14	18-5/8	3	814-019	1-7/32	1.2188	14	19-7/8	4	814-048
9/16	0.5625	14	18-5/8	3	814-020	1-1/4	1.2500	14	19-7/8	4	814-049
37/64	0.5781	14	18-5/8	3	814-021	1-9/32	1.2812	14	19-7/8	4	814-050
19/32	0.5938	14	18-5/8	3	814-022	1-5/16	1.3125	14	19-7/8	4	814-051
39/64	0.6094	14	18-5/8	3	814-023	1-11/32	1.3438	14	19-7/8	4	814-052
5/8	0.6250	14	18-5/8	3	814-024	1-3/8	1.3750	14	19-7/8	4	814-053
41/64	0.6406	14	18-5/8	3	814-025	1-13/32	1.4062	14	19-7/8	4	814-054
21/32	0.6562	14	18-5/8	3	814-026	1-7/16	1.4375	14	19-7/8	4	814-055
43/64	0.6719	14	18-5/8	3	814-027	1-15/32	1.4687	14	19-7/8	4	814-056
11/16	0.6875	14	18-5/8	3	814-028	1-1/2	1.5000	14	19-7/8	4	814-057
45/64	0.7031	14	18-5/8	3	814-029	1-9/16	1.5625	14	21	4	814-058
23/32	0.7188	14	18-5/8	3	814-030	1-5/8	1.6250	14	21	4	814-059
47/64	0.7344	14	18-5/8	3	814-031	1-11/16	1.6875	14	21	4	814-060
3/4	0.7500	14	18-5/8	3	814-032	1-3/4	1.7500	14	21	4	814-061
49/64	0.7656	14	18-5/8	3	814-033	1-13/16	1.8125	14	21	5	814-085
25/32	0.7812	14	18-5/8	3	814-034	1-7/8	1.8750	14	21	5	814-086
13/16	0.8125	14	18-5/8	3	814-035	1-15/16	1.9375	14	20-1/2	5	814-087
27/32	0.8438	14	18-5/8	3	814-036	2	2.0000	14	21	5	814-062

- For coolant entry specifications, see page 18.
- Specify finish when ordering where applicable



For hole concentricity we recommend using **Series 605 Spotting Drill**, see page 14.

TECHNICAL TIPS



We offer drill resharpener and reconditioning for all of our Drills. We also offer a variety of specialized drill points for specific applications. Please contact us for further information.



Visit our website at www.coolantfedtooling.com for technical information and our latest product offerings.



EXTRA LENGTH • 17" FLUTE • HIGH SPEED • TAPER SHANK

SERIES 817 • COOLANT-FED



SERIES: 817

SIZES

7/16" - 2"
INCH

General purpose drill works well in most all materials. Suitable for both horizontal and vertical drilling. Taper shank allows the tool to quickly adapt to drill presses or special drilling machines. Notched point provides good chip formation when the proper speeds and feeds are applied. Constant web thickness with rolled heel provides maximum chip clearance.

MATERIAL	BRIGHT	DARK	TIN
HSS	●	●	●
SPECIFICATIONS			
Helix: 32° -34° Spiral			
Point: 118° Notch			
Web: Standard			

DIAMETER INCH	DECIMAL (IN.)	FLUTE LGTH. (IN.)	OAL (IN.)	M.T.	PART NUMBER	DIAMETER (IN.)	DECIMAL (IN.)	FLUTE LGTH. (IN.)	OAL (IN.)	M.T.	PART NUMBER
7/16	0.4375	17	20-7/8	2	817-012	29/32	0.9062	17	21-5/8	3	817-038
7/16	0.4375	17	21-5/8	3	817-012A	15/16	0.9375	17	21-5/8	3	817-039
29/64	0.4531	17	20-7/8	2	817-013	31/32	0.9688	17	21-5/8	3	817-040
29/64	0.4531	17	21-5/8	3	817-013A	1	1.0000	17	21-5/8	3	817-041
15/32	0.4688	17	20-7/8	2	817-014	1-1/32	1.0313	17	21-5/8	3	817-042
15/32	0.4688	17	21-5/8	3	817-014A	1-1/16	1.0625	17	21-5/8	3	817-043
31/64	0.4844	17	21-5/8	3	817-015	1-1/16	1.0625	17	22-7/8	4	817-043A
1/2	0.5000	17	21-5/8	3	817-016	1-3/32	1.0938	17	22-7/8	4	817-044
33/64	0.5156	17	21-5/8	3	817-017	1-1/8	1.1250	17	22-7/8	4	817-045
17/32	0.5312	17	21-5/8	3	817-018	1-5/32	1.1562	17	22-7/8	4	817-046
35/64	0.5469	17	21-5/8	3	817-019	1-3/16	1.1875	17	22-7/8	4	817-047
9/16	0.5625	17	21-5/8	3	817-020	1-7/32	1.2188	17	22-7/8	4	817-048
37/64	0.5781	17	21-5/8	3	817-021	1-1/4	1.2500	17	22-7/8	4	817-049
19/32	0.5938	17	21-5/8	3	817-022	1-9/32	1.2812	17	22-7/8	4	817-050
39/64	0.6094	17	21-5/8	3	817-023	1-5/16	1.3125	17	22-7/8	4	817-051
5/8	0.6250	17	21-5/8	3	817-024	1-11/32	1.3438	17	22-7/8	4	817-052
41/64	0.6406	17	21-5/8	3	817-025	1-3/8	1.3750	17	22-7/8	4	817-053
21/32	0.6562	17	21-5/8	3	817-026	1-13/32	1.4062	17	22-7/8	4	817-054
43/64	0.6719	17	21-5/8	3	817-027	1-7/16	1.4375	17	22-7/8	4	817-055
11/16	0.6875	17	21-5/8	3	817-028	1-15/32	1.4687	17	22-7/8	4	817-056
45/64	0.7031	17	21-5/8	3	817-029	1-1/2	1.5000	17	22-7/8	4	817-057
23/32	0.7188	17	21-5/8	3	817-030	1-9/16	1.5625	17	24	4	817-058
47/64	0.7344	17	21-5/8	3	817-031	1-5/8	1.6250	17	24	4	817-059
3/4	0.7500	17	21-5/8	3	817-032	1-11/16	1.6875	17	24	4	817-060
49/64	0.7656	17	21-5/8	3	817-033	1-3/4	1.7500	17	24	4	817-061
25/32	0.7812	17	21-5/8	3	817-034	1-13/16	1.8125	17	24	5	817-085
13/16	0.8125	17	21-5/8	3	817-035	1-15/16	1.9375	17	24	5	817-087
27/32	0.8438	17	21-5/8	3	817-036	2	2.0000	17	24	5	817-062
7/8	0.8750	17	21-5/8	3	817-037						

- For coolant entry specifications, see page 18.
- Specify finish when ordering where applicable



For hole concentricity we recommend using **Series 605 Spotting Drill**, see page 14.

TECHNICAL TIPS



We offer drill sharpening and reconditioning for all of our Drills. We also offer a variety of specialized drill points for specific applications. Please contact us for further information.



Visit our website at www.coolantfedtooling.com for technical information and our latest product offerings.



EXTRA LENGTH • 19" FLUTE • HIGH SPEED • TAPER SHANK

SERIES 819 • COOLANT-FED



SERIES: 819

SIZES

7/16"-2"

INCH

General purpose drill works well in most all materials. Suitable for both horizontal and vertical drilling. Taper shank allows the tool to quickly adapt to drill presses or special drilling machines. Notched point provides good chip formation when the proper speeds and feeds are applied. Constant web thickness with rolled heel provides maximum chip clearance.

MATERIAL	BRIGHT	DARK	TIN
HSS	●	●	

SPECIFICATIONS

Helix: 32° -34° Spiral

Point: 118° Notch

Web: Standard

DIAMETER (IN.)	DECIMAL (IN.)	FLUTE LGTH. (IN.)	OAL (IN.)	M.T.	PART NUMBER	DIAMETER (IN.)	DECIMAL (IN.)	FLUTE LGTH. (IN.)	OAL (IN.)	M.T.	PART NUMBER
* 7/16	0.4375	19	22-7/8	2	819-012	* 47/64	0.7344	19	23-5/8	3	819-031
* 7/16	0.4375	19	23-5/8	3	819-012A	* 3/4	0.7500	19	23-5/8	3	819-032
* 29/64	0.4531	19	22-7/8	2	819-013	* 49/64	0.7656	19	23-5/8	3	819-033
* 29/64	0.4531	19	23-5/8	3	819-013A	* 25/32	0.7812	19	23-5/8	3	819-034
* 15/32	0.4688	19	22-7/8	2	819-014	* 13/16	0.8125	19	23-5/8	3	819-035
* 15/32	0.4688	19	23-5/8	3	819-014A	* 7/8	0.8750	19	23-5/8	3	819-037
* 31/64	0.4844	19	23-5/8	3	819-015	* 29/32	0.9062	19	23-5/8	3	819-038
* 1/2	0.5000	19	23-5/8	3	819-016	* 31/32	0.9688	19	23-5/8	3	819-040
* 35/64	0.5469	19	23-5/8	3	819-019	* 1-5/32	1.1562	19	24-7/8	4	819-046
* 37/64	0.5781	19	23-5/8	3	819-021	* 1-1/4	1.2500	19	24-7/8	4	819-049
* 19/32	0.5938	19	23-5/8	3	819-022	* 1-15/32	1.4688	19	24-7/8	4	819-056
* 39/64	0.6094	19	23-5/8	3	819-023	* 1-9/16	1.5625	19	26	4	819-058
* 43/64	0.6719	19	23-5/8	3	819-027	* 1-5/8	1.6250	19	26	4	819-059
* 45/64	0.7031	19	23-5/8	3	819-029	* 1-3/4	1.7500	19	26	4	819-061
* 23/32	0.7188	19	23-5/8	3	819-030	* 2	2.0000	19	26	5	819-062

* **Outgoing Items**



For hole concentricity we recommend using **Series 605 Spotting Drill**, see page 14.

SUPER LENGTH • HIGH SPEED • TAPER SHANK

SERIES 822 • COOLANT-FED • 22" FLUTE



SERIES: 822

SIZES

3/4"-1-1/8"

INCH

General purpose drill works well in most all materials. Suitable for both horizontal and vertical drilling. Taper shank allows the tool to quickly adapt to drill presses or special drilling machines. Notched point provides good chip formation when the proper speeds and feeds are applied. Constant web thickness with rolled heel provides maximum chip clearance.

MATERIAL	BRIGHT	DARK	TIN
HSS	●	●	

SPECIFICATIONS

Helix: 32° -34° Spiral

Point: 118° Notch

Web: Standard

DIAMETER (IN.)	DECIMAL (IN.)	FLUTE LGTH. (IN.)	OAL (IN.)	M.T.	PART NUMBER
* 3/4	0.7500	22	26-5/8	3	822-032
* 7/8	0.8750	22	26-5/8	3	822-037
* 1-1/8	1.1250	22	27-5/8	4	822-045

* **Outgoing Items**

SUPER LENGTH • HIGH SPEED • TAPER SHANK

SERIES 724 • COOLANT-FED • 24" Flute



SERIES: 724

SIZES

11/16"-1-15/16"

INCH

General purpose drill works well in most all materials. Suitable for both horizontal and vertical drilling. Taper shank allows the tool to quickly adapt to drill presses or special drilling machines. Notched point provides good chip formation when the proper speeds and feeds are applied. Constant web thickness with rolled heel provides maximum chip clearance.

MATERIAL	BRIGHT	DARK	TIN
HSS	●	●	

SPECIFICATIONS

Helix: 32° -34° Spiral

Point: 118° Notch

Web: Standard

DIAMETER (IN.)	DECIMAL (IN.)	FLUTE LGTH. (IN.)	OAL (IN.)	M.T.	PART NUMBER	DIAMETER (IN.)	DECIMAL (IN.)	FLUTE LGTH. (IN.)	OAL (IN.)	M.T.	PART NUMBER
* 11/16	0.6875	24	28-3/4	3	724-028	* 1-1/2	1.5000	24	29-5/8	4	724-057
* 3/4	0.7500	24	28-5/8	3	724-032	* 1-15/16	1.9375	24	31	5	724-087
* 7/8	0.8750	24	28-5/8	3	724-037	* Outgoing Items					

* **Outgoing Items**

• For coolant entry specifications, see page 18. • Specify finish when ordering where applicable.



HIGH PERFORMANCE END MILL • THREE FLUTE/SOLID CARBIDE/ULTRA GOLD COATING • STRAIGHT SHANK

SERIES 921 CORNER RADIUS ROUGHER • COOLANT-FED



- 35° helix
- Suitable for most materials
- Designed for profiling, slotting and end cutting



SERIES 922 FINISHER • COOLANT-FED



- 35° helix
- Suitable for most materials
- Designed for slotting, pocketing and finishing



PART NUMBER	TOOL DIAMETER		SHANK DIA. (IN.)	FLUTE LENGTH (IN.)	OAL (IN.)	CORNER RADIUS
	INCH	DECIMAL				
921-02500	1/4	0.2500	0.2500	3/4	2-1/2	0.015-0.020
921-03750	3/8	0.3750	0.3750	1	2-1/2	0.015-0.020
921-05000	1/2	0.5000	0.5000	1	3	0.030-0.035
921-07500	3/4	0.7500	0.7500	1-1/2	4	0.030-0.035

PART NUMBER	TOOL DIAMETER		SHANK DIA. (IN.)	FLUTE LENGTH (IN.)	OAL (IN.)
	INCH	DECIMAL			
922-02500	1/4	0.2500	0.2500	3/4	2-1/2
922-03750	3/8	0.3750	0.3750	1	2-1/2
922-05000	1/2	0.5000	0.5000	1-1/4	3
922-07500	3/4	0.7500	0.7500	1-5/8	4

HIGH PERFORMANCE END MILL • FOUR INDIVIDUAL FLUTES • SOLID CARBIDE • PROPRIETARY SIX COAT FINISH

HURRICANE™ SERIES 923 CORNER RADIUS • COOLANT-FED



- 35° to 38° helix
- Synchronized cutting action eliminates vibration
- Recommended for stainless steels, high temperature alloys, cast iron, low carbon steels as well as tool & die steels.



HURRICANE™ SERIES 924 SQUARE CORNER • COOLANT-FED



- 35° to 38° helix
- Synchronized cutting action eliminates vibration
- Recommended for stainless steels, high temperature alloys, cast iron, low carbon steels as well as tool & die steels.



PART NUMBER	TOOL DIAMETER		SHANK DIA. (IN.)	FLUTE LENGTH (IN.)	OAL (IN.)	CORNER RADIUS
	INCH	DECIMAL				
923-02500	1/4	0.2500	0.2500	3/4	2-1/2	0.015-0.020
923-03750	3/8	0.3750	0.3750	1	2-1/2	0.015-0.020
923-05000	1/2	0.5000	0.5000	1	3	0.015-0.020
923-06250	5/8	0.6250	0.6250	1-1/2	4	0.025-0.030
923-07500	3/4	0.7500	0.7500	1-1/2	4	0.030-0.035

PART NUMBER	TOOL DIAMETER		SHANK DIA. (IN.)	FLUTE LENGTH (IN.)	OAL (IN.)
	INCH	DECIMAL			
924-02500	1/4	0.2500	0.2500	3/4	2-1/2
924-03750	3/8	0.3750	0.3750	1	2-1/2
924-05000	1/2	0.5000	0.5000	1	3
924-06250	5/8	0.6250	0.6250	1-1/2	4
924-07500	3/4	0.7500	0.7500	1-1/2	4

• For coolant thru milling chuck holders see our holder section, page 37.



Visit our website at www.coolantfedtooling.com for technical information and our latest product offerings.



PRECISION MILLING CHUCKS

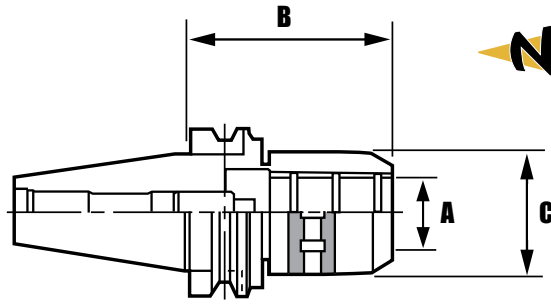

NEW

**COOLANT-FED
END MILLS**

SERIES PMC • COOLANT-FED

- Radial and axial groove gripping ensure accuracy and have 5-6 times more grip torque than ER and/or TG systems
- Complete with coolant sealing depth adjustment screw
- Available in CAT, BT and HSK style flanges
- Metric and inch size straight reducing collets available
- Excellent choice for tough roughing as well as fine finishing
- Symmetrically balanced for speeds up to 10,000 RPM
- 0.0002 TIR at 4x Diameter
- Meets AT3 Taper Specification

Coolant-Fed Milling Chucks

The George Whalley Company precision milling chucks provide maximum performance for solid carbide, carbide tipped and indexable tools. All chucks are sealed with an adjustment screw at the back end of the toolholder eliminating the need for sealed collets. The combination of radial and axial grooves provides the best grip in the marketplace, 0.0002 TIR accuracy. These chucks are great for roughing or fine finishing applications and are available in CAT V holders, BT holders and HSK holders.

SHANK	A		MM	B		C	PART NUMBER
	DECIMAL	INCH		DECIMAL	DECIMAL		
CAT40	0.750	3/4	85	3.350	2.090	C40-PMC-0.750-085 *	
CAT40	1.250	1-1/4	90	3.540	2.760	C40-PMC-1.250-090	
CAT50	0.750	3/4	105	4.130	2.090	C50-PMC-0.750-105	
CAT50	1.250	1-1/4	90	3.540	2.910	C50-PMC-1.250-090	
CAT50	1.250	1-1/4	105	4.130	2.910	C50-PMC-1.250-105	
BT40	0.750	3/4	75	2.950	2.090	B40-PMC-0.750-075	
BT40	1.250	1-1/4	85	3.350	2.760	B40-PMC-1.250-085	
HSK63A	0.750	3/4	95	3.740	2.090	H63-PMC-0.750-095	
HSK63A	1.250	1-1/4	100	3.940	2.760	H63-PMC-1.250-100	

* CFT C40-PMC 0.750-085 #904 short projection milling chuck does not meet ANSI specifications

REDUCING COLLETS		REDUCING COLLETS	
3/4" MILL CHUCKS	SIZE	1-1/4" MILL CHUCKS	SIZE
PMC 0.750-0125	1/8"	PMC 1.250-0125	1/8"
PMC 0.750-0187	3/16"	PMC 1.250-0187	3/16"
PMC 0.750-0250	1/4"	PMC 1.250-0250	1/4"
PMC 0.750-0312	5/16"	PMC 1.250-0312	5/16"
PMC 0.750-0375	3/8"	PMC 1.250-0375	3/8"
PMC 0.750-0437	7/16"	PMC 1.250-0437	7/16"
PMC 0.750-0500	1/2"	PMC 1.250-0500	1/2"
PMC 0.750-0625	5/8"	PMC 1.250-0625	5/8"
PMC 0.750-06MM	6.00MM	PMC 1.250-0750	3/4"
PMC 0.750-06MM	8.00MM	PMC 1.250-0812	13/16"
PMC 0.750-10MM	10.00MM	PMC 1.250-0875	7/8"
PMC 0.750-12MM	12.00MM	PMC 1.250-0937	15/16"
PMC 0.750-14MM	14.00MM	PMC 1.250-1000	1"
PMC 0.750-16MM	16.00MM	PMC 1.250-06MM	6.00MM
		PMC 1.250-08MM	8.00MM
		PMC 1.250-10MM	10.00MM
		PMC 1.250-12MM	12.00MM
		PMC 1.250-14MM	14.00MM
		PMC 1.250-16MM	16.00MM

- STOP SCREWS: All chucks are supplied with PMC-CSC - standard length stop screw complete with an extension kit for use with our reducing collets listed above
- Order part number PMC-CSC-XL if a longer length stop screw is required
- Coolant through the spindle machining centers that use HSK holders require part number PMC-HSK-Coolant tube.



CHUCKING REAMERS • M42 COBALT STEEL • STRAIGHT SHANK

SERIES 607 • COOLANT-FED



SERIES: 607

- One Coolant Hole Per Flute
- Staggered Coolant Holes for Maximum Strength
- For Thru or Blind Holes

- M42 Cobalt High Speed Steel
- Straight Flute
- R.H. Cut

TOLERANCES

5/16" - 1/2" dia.	17/32" - 5/8" dia.	21/32" - 1" dia.
+ .0002"/-.0000"	+ .0003"/-.0000"	+ .0005"/-.0000"

SIZES
5/16"-1" INCH

DIA. INCH	DECIMAL (IN.)	NO. OF FLUTES	FLUTE (IN.)	OAL (IN.)	SHANK DIA. (IN.)	PART NUMBER
* 5/16	0.3125	6	1-1/2	6	0.2792	607-013
* 11/32	0.3438	6	1-1/2	6	0.2792	607-015
* 3/8	0.3750	6	1-3/4	7	0.3105	607-017
* 13/32	0.4062	6	1-3/4	7	0.3105	607-019
* 7/16	0.4375	6	1-3/4	7	0.3750	607-021
* 15/32	0.4688	6	1-3/4	7	0.3750	607-023
* 1/2	0.5000	6	2	8	0.4355	607-025
* 17/32	0.5312	6	2	8	0.4355	607-027
* 9/16	0.5625	6	2	8	0.4355	607-029
* 19/32	0.5938	6	2	8	0.4355	607-031
* 5/8	0.6250	6	2-1/4	9	0.5620	607-033
* 21/32	0.6562	8	2-1/4	9	0.6520	607-035

* **Outgoing Items**

DIA. (IN.)	DECIMAL (IN.)	NO. OF FLUTES	FLUTE (IN.)	OAL (IN.)	SHANK DIA. (IN.)	PART NUMBER
* 11/16	0.6875	8	2-1/4	9	0.5620	607-037
* 23/32	0.7188	8	2-1/4	9	0.5620	607-039
* 3/4	0.7500	8	2-1/2	9-1/2	0.6245	607-041
* 25/32	0.7812	8	2-1/2	9-1/2	0.6245	607-043
* 13/16	0.8125	8	2-1/2	9-1/2	0.6245	607-045
* 27/32	0.8438	8	2-1/2	9-1/2	0.6245	607-047
* 7/8	0.8750	8	2-5/8	10	0.7495	607-049
* 29/32	0.9062	8	2-5/8	10	0.7495	607-051
* 15/16	0.9375	8	2-5/8	10	0.7495	607-053
* 31/32	0.9688	8	2-5/8	10	0.7495	607-055
* 1	1.0000	8	2-3/4	10-1/2	0.8745	607-057

* **Outgoing Items**

CHUCKING REAMERS • SPECIAL DECIMAL SIZE • M42 COBALT STEEL • STRAIGHT SHANK

SERIES S607 • COOLANT-FED



SERIES: S607

- M42 Cobalt High Speed Steel
- Staggered Coolant Holes for Maximum Strength
- One Coolant Hole Per Flute

- Straight Flute
- For Thru or Blind Holes
- R.H. Cut

TOLERANCES

.2969"-.4999" dia.	.5001"-.6249" dia.	.6251"-.999" dia.
+ .0002"/-.0000"	+ .0003"/-.0000"	+ .0005"/-.0000"

SIZES
0.2969"-0.9999" INCH

DECIMAL RANGE (IN.)	NO. OF FLUTES	FLUTE (IN.)	OAL (IN.)	SHANK DIA. (IN.)	PART NUMBER
* 0.2969-0.3125	6	1-1/2	6	0.2792	S607-*-01
* 0.3126-0.3437	6	1-1/2	6	0.2792	S607-*-02
* 0.3439-0.3749	6	1-3/4	7	0.3105	S607-*-03
* 0.3751-0.4061	6	1-3/4	7	0.3105	S607-*-04
* 0.4063-0.4374	6	1-3/4	7	0.3730	S607-*-05
* 0.4376-0.4687	6	1-3/4	7	0.3750	S607-*-06
* 0.4689-0.4999	6	2	8	0.4355	S607-*-07
* 0.5001-0.5311	6	2	8	0.4355	S607-*-08
* 0.5313-0.5624	6	2	8	0.4355	S607-*-09
* 0.5626-0.5937	6	2	8	0.4355	S607-*-10
* 0.5938-0.6249	6	2-1/4	9	0.5620	S607-*-11
* 0.6251-0.6561	8	2-1/4	9	0.5620	S607-*-12

* **Outgoing Items**

DECIMAL RANGE (IN.)	NO. OF FLUTES	FLUTE (IN.)	OAL (IN.)	SHANK DIA. (IN.)	PART NUMBER
* 0.6563-0.6874	8	2-1/4	9	0.5620	S607-*-13
* 0.6876-0.7187	8	2-1/4	9	0.5620	S607-*-14
* 0.7189-0.7499	8	2-1/2	9-1/2	0.6245	S607-*-15
* 0.7501-0.7811	8	2-1/2	9-1/2	0.6245	S607-*-16
* 0.7813-0.8124	8	2-1/2	9-1/2	0.6245	S607-*-17
* 0.8126-0.8437	8	2-1/2	9-1/2	0.6245	S607-*-18
* 0.8439-0.8749	8	2-5/8	10	0.7495	S607-*-19
* 0.8751-0.9061	8	2-5/8	10	0.7495	S607-*-20
* 0.9062-0.9374	8	2-5/8	10	0.7495	S607-*-21
* 0.9376-0.9687	8	2-5/8	10	0.7495	S607-*-22
* 0.9689-0.9999	8	2-3/4	10-1/2	0.8745	S607-*-23

* **Outgoing Items**

Note : When ordering Series S607 reamers, specify the exact decimal size required in the place where the asterisk is shown.

For example, to order a 0.6820 diameter reamer use S607-6820-13.

Additional Specifications for SERIES 607 & S607 - End Entry Feeds:

0.2969" to 0.6249" , Cupped End Coolant Entry • 0.6251" to 0.7187", 1/8 NPT Tapped Coolant Entry • 0.7501" to 0.9999", 1/4 NPT Tapped Coolant Entry



CHUCKING REAMERS • C-2 CARBIDE TIPPED • STRAIGHT SHANK

SERIES 606 • COOLANT-FED



SERIES: 606

SIZES

9/16"-1-1/16"
INCH

- One Coolant Hole Per Flute
- Staggered Coolant Holes for Maximum Strength

- Straight Flute
- R.H. Cut

• TOLERANCES •

9/16" - 5/8" dia.

11/16" - 1" dia.

+ .0003"/-.0000"

+ .0005"/-.0000"

DIA. (IN.)	DECIMAL (IN.)	NO. OF FLUTES	FLUTE (IN.)	OAL (IN.)	SHANK DIA. (IN.)	PART NUMBER	DIA. (IN.)	DECIMAL (IN.)	NO. OF FLUTES	FLUTE (IN.)	OAL (IN.)	SHANK DIA. (IN.)	PART NUMBER
9/16	0.5625	6	2	8	7/16	606-029	13/16	0.8125	6	2-1/2	9-1/2	5/8	606-045
19/32	0.5938	6	2	8	7/16	606-031	27/32	0.8438	6	2-1/2	9-1/2	5/8	606-047
5/8	0.6250	6	2-1/4	9	9/16	606-033	7/8	0.8750	6	2-5/8	10	3/4	606-049
21/32	0.6562	6	2-1/4	9	9/16	606-035	29/32	0.9062	6	2-5/8	10	3/4	606-051
11/16	0.6875	6	2-1/4	9	9/16	606-037	15/16	0.9375	8	2-5/8	10	3/4	606-053
23/32	0.7188	6	2-1/4	9	9/16	606-039	31/32	0.9688	8	2-5/8	10	3/4	606-055
3/4	0.7500	6	2-1/2	9-1/2	5/8	606-041	1	1.0000	8	2-3/4	10-1/2	7/8	606-057
25/32	0.7812	6	2-1/2	9-1/2	5/8	606-043	1-1/16	1.0625	8	2-3/4	10-1/2	7/8	606-059

COOLANT-FED REAMERS AND T-SLOT CUTTERS

CHUCKING REAMERS • SPECIAL DECIMAL SIZE • C-2 CARBIDE TIPPED • STRAIGHT SHANK

SERIES S606 • COOLANT-FED



SERIES: S606

SIZES

0.5469"-1.0625"
INCH

- One Coolant Hole Per Flute
- Staggered Coolant Holes for Maximum Strength

- Straight Flute
- R.H. Cut

• TOLERANCES •

.5469" - .6562" dia.

.6563" - 1.0625" dia.

+ .0003"/-.0000"

+ .0005"/-.0000"

DECIMAL RANGE (IN.)	NO. OF FLUTES	FLUTE (IN.)	OAL (IN.)	SHANK DIA. (IN.)	PART NUMBER	DECIMAL RANGE (IN.)	NO. OF FLUTES	FLUTE (IN.)	OAL (IN.)	SHANK DIA. (IN.)	PART NUMBER
0.5469-0.5625	6	2	8	7/16	S606-*-01	0.7813-0.8125	6	2-1/2	9-1/2	5/8	S606-*-09
0.5626-0.5938	6	2	8	7/16	S606-*-02	0.8126-0.8438	6	2-1/2	9-1/2	5/8	S606-*-10
0.5939-0.6250	6	2-1/4	9	9/16	S606-*-03	0.8439-0.8750	6	2-5/8	10	3/4	S606-*-11
0.6251-0.6562	6	2-1/4	9	9/16	S606-*-04	0.8751-0.9062	6	2-5/8	10	3/4	S606-*-12
0.6563-0.6875	6	2-1/4	9	9/16	S606-*-05	0.9063-0.9375	8	2-5/8	10	3/4	S606-*-13
0.6876-0.7188	6	2-1/4	9	9/16	S606-*-06	0.9376-0.9688	8	2-5/8	10	3/4	S606-*-14
0.7189-0.7500	6	2-1/2	9-1/2	5/8	S606-*-07	0.9689-1.0000	8	2-3/4	10-1/2	7/8	S606-*-15
0.7501-0.7812	6	2-1/2	9-1/2	5/8	S606-*-08	1.0001-1.0625	8	2-3/4	10-1/2	7/8	S606-*-16

Note : When ordering Series S606 reamers, specify the exact decimal size required in the place where the asterisk is shown.

For example, to order a 0.5470 diameter reamer use S606-5470-01.

Additional Specifications for SERIES 606 & S606 - End Entry Feeds:

0.5469" to 0.6249" , Cupped End Coolant Entry • 0.6251" to 0.7187" , 1/8 NPT Tapped Coolant Entry • 0.7501" to 1.0625" , 1/4 NPT Tapped Coolant Entry



HEAT EXCHANGER REAMERS • M42 COBALT STEEL • TAPER SHANK

SERIES 608 • COOLANT-FED



SERIES: 608

SIZES
9/16"-1-1/16"
INCH

- Staggered coolant holes for maximum strength
- Dual Coolant Entry : Removable tang end plug or side entry morse taper
- Left hand spiral flutes for ease of chip ejection & excellent finish
- Designed for deep hole applications

- M42 Cobalt High Speed
- 15° Left-Hand Spiral
- R.H.Cut
- Two coolant holes per flute

• TOLERANCES •

9/16" - 5/8" dia.	21/32" - 1" dia.	1-1/16" dia.
+ .0003"/-.0001"	+ .0005"/-.0000"	+ .0006"/-.0002"

DIA. (IN.)	DECIMAL (IN.)	NO. OF FLUTES	FLUTE (IN.)	OAL (IN.)	SHANK	PART NUMBER	DIA. (IN.)	DECIMAL (IN.)	NO. OF FLUTES	FLUTE (IN.)	OAL (IN.)	SHANK	PART NUMBER
9/16	0.5625	6	6	14	3MT	608-021	13/16	0.8125	8	6	14	3MT	608-037
19/32	0.5938	6	6	14	3MT	608-023	27/32	0.8438	8	6	14	3MT	608-039
5/8	0.6250	6	6	14	3MT	608-025	7/8	0.8750	8	6	14	3MT	608-041
21/32	0.6562	8	6	14	3MT	608-027	29/32	0.9062	8	6	14	3MT	608-043
11/16	0.6875	8	6	14	3MT	608-029	15/16	0.9375	8	6	14	3MT	608-045
23/32	0.7188	8	6	14	3MT	608-031	31/32	0.9688	8	6	14	3MT	608-047
3/4	0.7500	8	6	14	3MT	608-033	1	1.0000	8	6	14	3MT	608-049
25/32	0.7812	8	6	14	3MT	608-035	1-1/16	1.0625	8	6	14	3MT	608-051

HEAT EXCHANGER REAMERS • SPECIAL DECIMAL SIZE • M42 COBALT STEEL • TAPER SHANK

SERIES S608 • COOLANT-FED



SERIES: S608

SIZES
0.5469"-1.0625"
INCH

- Dual Coolant Entry : Removable tang end plug or side entry morse taper
- Left hand spiral flutes for ease of chip ejection & excellent finish
- Designed for deep hole applications
- Staggered coolant holes for maximum strength

- M42 Cobalt High Speed
- 15° Left-Hand Spiral
- R.H.Cut
- Two coolant holes per flute

• TOLERANCES •

.5469"-.6562" dia.	.6563"-1.0000 dia.	1.001"-1.0625" dia.
+ .0003"/-.0001"	+ .0005"/-.0000"	+ .0006"/-.0002"

DECIMAL RANGE (IN.)	NO. OF FLUTES	FLUTE (IN.)	OAL (IN.)	SHANK	PART NUMBER	DECIMAL RANGE (IN.)	NO. OF FLUTES	FLUTE (IN.)	OAL (IN.)	SHANK	PART NUMBER
0.5469-0.5625	6	6	14	3MT	S608-*-01	0.7813-0.8125	8	6	14	3MT	S608-*-09
0.5626-0.5938	6	6	14	3MT	S608-*-02	0.8126-0.8438	8	6	14	3MT	S608-*-10
0.5939-0.6250	6	6	14	3MT	S608-*-03	0.8439-0.8750	8	6	14	3MT	S608-*-11
0.6251-0.6562	8	6	14	3MT	S608-*-04	0.8751-0.9062	8	6	14	3MT	S608-*-12
0.6563-0.6875	8	6	14	3MT	S608-*-05	0.9063-0.9375	8	6	14	3MT	S608-*-13
0.6876-0.7188	8	6	14	3MT	S608-*-06	0.9376-0.9688	8	6	14	3MT	S608-*-14
0.7189-0.7500	8	6	14	3MT	S608-*-07	0.9689-1.0000	8	6	14	3MT	S608-*-15
0.7501-0.7812	8	6	14	3MT	S608-*-08	1.0001-1.0625	8	6	14	3MT	S608-*-16

Note : When ordering Series S608 reamers, specify the exact decimal size required in the place where the asterisk is shown.
For example, to order a 0.5469 diameter reamer use S608-5469-01.



T-SLOT CUTTERS • SUPER COBALT STEEL

SERIES 810



Patent No. 3,597,817

SERIES: 810

SIZES

3/8"-1-1/2"
INCH

Because of the greater speed and feed capabilities, production rates when cutting T-slots are improved from 2 to 5 times.

The coolant pressure forces chips ahead of the cutter. Since the cutter need not be backed out to remove impact chips, a T-slot can be cut in one pass.

With coolant brought right to the cutting edge, the tool is kept cool at all times, extending its life. This also lubricates the cutting edge to eliminate galling, to minimize recutting chips and to facilitate chip removal.

The final result is a T-slot with a better finish and closer tolerances, produced more quickly with less wear on the tool.

COOLANT-FED
REAMERS AND
T-SLOT CUTTERS

PART NUMBER	OLD PART NUMBER	BOLT SIZE (IN.)	DIAMETER OF CUTTER (IN.)	THICKNESS OF CUTTER (IN.)	DIAMETER OF NECK (IN.)	OVERALL LENGTH (IN.)	SHANK DIA. (IN.)	UNDERCUT LENGTH (IN.)	NO. FLUTES
* 810-001	OTC-3	3/8	25/32	21/64	13/32	3-1/4	3/4	55/64	6
* 810-002	OTC-4	1/2	31/32	25/64	17/32	3-7/16	3/4	63/64	6
* 810-003	OTC-5	5/8	1-1/4	31/64	21/32	3-15/16	1	1-9/64	6
* 810-004	OTC-6	3/4	1-15/32	5/8	25/32	4-7/16	1	1-1/2	8
* 810-005	OTC-7	1	1-27/32	53/64	1-1/32	4-13/16	1-1/4	1-43/64	8
* 810-006	OTC-8	1-1/4	2-7/32	1-3/32	1-7/32	5-3/8	1-1/4	1-31/32	8
* 810-007	OTC-9	1-1/2	2-21/32	1-11/32	1-17/32	5-29/32	1-1/4	2-1/8	10

* **Outgoing Items**

SPECIAL COOLANT-FED CUTTING TOOLS

Our experienced tooling engineers will provide quotes on special tooling per your specifications. Some of the more popular materials and special tools are listed below. Fax your special tooling requests to us at (216) 481-9966 or e-mail them to: sales@coolantfedtooling.com.

MATERIALS

- High Speed
- Cobalt
- Solid Carbide
- Carbide Tipped

SPECIAL TOOLS

- Porting Tools
- Combination Tools
- Step Drills
- Fluted Milling Tools
- Forming Tools
- Dovetail Cutters
- Conventional & Special Shanks





COOLANT-FED TAPS FOR THRU HOLE • MEDIUM HOOK • SPIRAL POINT PLUG

Medium Hook for the following material groups:

Medium & Low Carbon Steel to 23 Rc, Ductile Iron, Brass, Bronze, & Thermo Plastic

Note: Standard Thru Hole Application Taps are designed to flush chips from the work hole per angled coolant holes along the tap flutes. This flushing / cooling action removes chips from the lead thread of the tap keeping chips from hindering the cutting action of the tap.



Thru Hole - Spiral Point

Note : Other surface treatments available upon request.

SIZE	THREAD LIMIT	NO. OF FLUTES	PART NO. PLUG CHAMFER
1/4-20 NC	H-3	3	325-025M
1/4-28 NF	H-3	3	325-045M
5/16-18 NC	H-3	3	331-025M
5/16-24 NF	H-3	3	331-045M
3/8-16 NC	H-3	3	337-025M
3/8-24 NF	H-3	3	337-045M
7/16-14 NC	H-3	4	343-025M
7/16-20 NF	H-3	4	343-045M
1/2-13 NC	H-3	4	350-025M
1/2-20 NF	H-3	4	350-045M

SIZE	THREAD LIMIT	NO. OF FLUTES	PART NO. PLUG CHAMFER
9/16-12 NC	H-3	4	356-025M
9/16-18 NF	H-3	4	356-045M
5/8-11 NC	H-3	4	362-025M
5/8-18 NF	H-3	4	362-045M
3/4-10 NC	H-3	4	375-025M
3/4-16 NF	H-3	4	375-045M
7/8-9 NC	H-4	4	387-025M
7/8-14 NF	H-4	4	387-045M
1"-8 NC	H-4	4	399-025M
1"-12 NF	H-4	4	399-045M

• Premium High Speed Steel - Bright Finish • See Tapping Systems beginning on page 148 for Tap Holders & Adapters

COOLANT-FED TAPS FOR THRU HOLE • HIGH HOOK • SPIRAL POINT PLUG

High Hook for the following material groups:

Stainless, Titanium, Monel, Aluminum Alloys, Copper, Manganese Bronze, Magnesium, & Zinc

Note: Standard Thru Hole Application Taps are designed to flush chips from the work hole per angled coolant holes along the tap flutes. This flushing / cooling action removes chips from the lead thread of the tap keeping chips from hindering the cutting action of the tap.



Thru Hole - Spiral Point

Note : Other surface treatments available upon request.

SIZE	THREAD LIMIT	NO. OF FLUTES	PART NO. PLUG CHAMFER
1/4-20 NC	H-3	3	325-025H
1/4-28 NF	H-3	3	325-045H
5/16-18 NC	H-3	3	331-025H
5/16-24 NF	H-3	3	331-045H
3/8-16 NC	H-3	3	337-025H
3/8-24 NF	H-3	3	337-045H
7/16-14 NC	H-3	4	343-025H
7/16-20 NF	H-3	4	343-045H
1/2-13 NC	H-3	4	350-025H
1/2-20 NF	H-3	4	350-045H

SIZE	THREAD LIMIT	NO. OF FLUTES	PART NO. PLUG CHAMFER
9/16-12 NC	H-3	4	356-025H
9/16-18 NF	H-3	4	356-045H
5/8-11 NC	H-3	4	362-025H
5/8-18 NF	H-3	4	362-045H
3/4-10 NC	H-3	4	375-025H
3/4-16 NF	H-3	4	375-045H
7/8-9 NC	H-4	4	387-025H
7/8-14 NF	H-4	4	387-045H
1"-8 NC	H-4	4	399-025H
1"-12 NF	H-4	4	399-045H

• Premium High Speed Steel - Bright Finish • See Tapping Systems beginning on page 148 for Tap Holders & Adapters



COOLANT-FED TAPS FOR BLIND HOLE • MEDIUM HOOK • 4 FLUTE BOTTOM

Medium Hook for the following material groups:

Medium & Low Carbon Steel to 23 Rc, Ductile Iron, Brass, Bronze, & Thermo Plastic

Note: Standard Blind Hole Application Taps are designed to evacuate chips along the flutes from the blind hole. These taps have a thru hole in the center, where the coolant forces the chips out through the flutes of the tap in order to keep chips from hindering the cutting action of the tap.

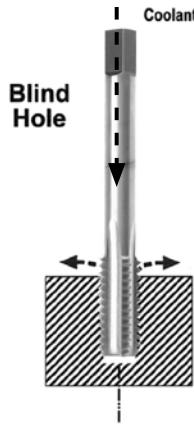

Blind Hole - 4 Flute

Note : Other surface treatments available upon request.

SIZE	THREAD LIMIT	PART NO. PLUG CHAMFER	PART NO. BOTTOM CHAMFER	SIZE	THREAD LIMIT	PART NO. PLUG CHAMFER	PART NO. BOTTOM CHAMFER
1/4-20 NC	H-3	325-125M	325-120M	9/16-12 NC	H-3	356-125M	356-120M
1/4-28 NF	H-3	325-145M	325-140M	9/16-18 NF	H-3	356-145M	356-140M
5/16-18 NC	H-3	331-125M	331-120M	5/8-11 NC	H-3	362-125M	362-120M
5/16-24 NF	H-3	331-145M	331-140M	5/8-18 NF	H-3	362-145M	362-140M
3/8-16 NC	H-3	337-125M	337-120M	3/4-10 NC	H-3	375-125M	375-120M
3/8-24 NF	H-3	337-145M	337-140M	3/4-16 NF	H-3	375-145M	375-140M
7/16-14 NC	H-3	343-125M	343-120M	7/8-9 NC	H-4	387-125M	387-120M
7/16-20 NF	H-3	343-145M	343-140M	7/8-14 NF	H-4	387-145M	387-140M
1/2-13 NC	H-3	350-125M	350-120M	1"-8 NC	H-4	399-125M	399-120M
1/2-20 NF	H-3	350-145M	350-140M	1"-12 NF	H-4	399-145M	399-140M

• Premium High Speed Steel - Bright Finish • See Tapping Systems beginning on page 148 for Tap Holders & Adapters

COOLANT-FED TAPS

COOLANT-FED TAPS FOR BLIND HOLES • HIGH HOOK • 4 FLUTE BOTTOM

High Hook for the following material groups:

Stainless, Titanium, Monel, Aluminum Alloys, Copper, Manganese Bronze, Magnesium, & Zinc

Note: Standard Blind Hole Application Taps are designed to evacuate chips along the flutes from the blind hole. These taps have a thru hole in the center, where the coolant forces the chips out through the flutes of the tap in order to keep chips from hindering the cutting action of the tap.

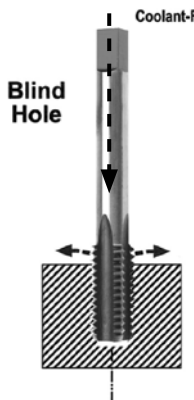

Blind Hole - 4 Flute

Note : Other surface treatments available upon request.

SIZE	THREAD LIMIT	PART NO. PLUG CHAMFER	PART NO. BOTTOM CHAMFER	SIZE	THREAD LIMIT	PART NO. PLUG CHAMFER	PART NO. BOTTOM CHAMFER
1/4-20 NC	H-3	325-125H	325-120H	9/16-12 NC	H-3	356-125H	356-120H
1/4-28 NF	H-3	325-145H	325-140H	9/16-18 NF	H-3	356-145H	356-140H
5/16-18 NC	H-3	331-125H	331-120H	5/8-11 NC	H-3	362-125H	362-120H
5/16-24 NF	H-3	331-145H	331-140H	5/8-18 NF	H-3	362-145H	362-140H
3/8-16 NC	H-3	337-125H	337-120H	3/4-10 NC	H-3	375-125H	375-120H
3/8-24 NF	H-3	337-145H	337-140H	3/4-16 NF	H-3	375-145H	375-140H
7/16-14 NC	H-3	343-125H	343-120H	7/8-9 NC	H-4	387-125H	387-120H
7/16-20 NF	H-3	343-145H	343-140H	7/8-14 NF	H-4	387-145H	387-140H
1/2-13 NC	H-3	350-125H	350-120H	1"-8 NC	H-4	399-125H	399-120H
1/2-20 NF	H-3	350-145H	350-140H	1"-12 NF	H-4	399-145H	399-140H

• Premium High Speed Steel - Bright Finish • See Tapping Systems beginning on page 148 for Tap Holders & Adapters



STANDARD PLUG & BOTTOM TAP DIMENSIONS

SIZE (IN.)	METRIC SIZE	OVERALL LENGTH (IN.)	THREAD LENGTH (IN.)	SQUARE LENGTH (IN.)	SHANK DIA. (IN.)	OIL HOLE (IN.)
1/4	M6	2-1/2	5/8	5/16	0.255	0.040
5/16	M8	2-23/32	11/16	3/8	0.318	0.052
3/8	M10	2-15/16	3/4	7/16	0.381	0.063
7/16	-	3-5/32	7/8	13/32	0.323	0.070
1/2	M12	3-3/8	15/16	7/16	0.367	0.081
9/16	-	3-19/32	1	1/2	0.429	0.094
5/8	-	3-13/16	1-3/32	9/16	0.480	0.102
3/4	-	4-1/4	1-7/32	11/16	0.590	0.126
7/8	-	4-11/16	1-11/32	3/4	0.697	0.141
1	-	5-1/8	1-1/2	13/16	0.800	0.161

The George Whalley Co.

can provide a full range of special coolant-fed taps to meet your tapping requirements.

OUR CAPABILITIES INCLUDE:

- SPECIAL PREMIUM STEEL
- SPECIAL DIAMETER & PITCHES
- METRICS
- RIGHT & LEFT HAND
- STRAIGHT FLUTE
- PIPE TAPS
- EXTENSION TAPS
- PULLEY TAPS
- BLUE PRINT SPECIALS
- FULL RANGE OF SURFACE TREATMENTS

PLEASE SPECIFY:

1. NOMINAL DIAMETER (inch or metric)

2. NUMBER OF THREADS PER INCH (or metric pitch)

3. CLASS OF FIT OR PITCH DIAMETER TOLERANCE

4. DIRECTION OF CUT (right or left hand)

5. TYPE OF TAP (straight flute)

6. STYLE (taper, plug or bottoming)

7. COOLANT PASSAGE (thru center of tap)

8. MATERIAL TO BE TAPPED



Visit our website at www.coolantfedtooling.com for technical information and our latest product offerings.

Please Note: For many special application coolant-fed taps we can best serve you when provided with a sample part, blue print and a sample of the tap you are currently using.



TAP DRILL SIZE CHART - STOCK SIZE DRILLS

TAP	TAP DRILL	DECIMAL EQUIVALENT OF TAP DRILL	THEORETICAL % OF THREAD	TAP	TAP DRILL	DECIMAL EQUIVALENT OF TAP DRILL	THEORETICAL % OF THREAD
1/4-20	9	0.1960	83	7/16-20	W	0.3860	79
	8	0.1990	79		25/64	0.3906	72
	7	0.2010	75		X	0.3970	62
1/4-28	13/64	0.2031	72.5	1/2-13	27/64	0.4219	78
	6	0.2040	71	7/16	0.4375	63	
	5	0.2055	69	1/2-20	29/64	0.4531	72
	4	0.2090	63	9/16-12	15/32	0.4688	87
	3	0.2130	80	31/64	0.4844	72	
5/16-18	7/32	0.2188	67	9/16-18	1/2	0.5000	87
	2	0.2210	63	33/64	0.5156	65	
	F	0.2570	77	5/8-11	17/32	0.5312	79
	G	0.2610	71	35/64	0.5469	66	
5/16-24	17/64	0.2656	65	5/8-18	9/16	0.5625	87
	H	0.2660	64	37/64	0.5781	65	
	H	0.2660	86	3/4-10	41/64	0.6406	84
	I	0.2720	75	21/32	0.6562	72	
	J	0.2770	66	3/4-16	11/16	0.6875	77
3/8-16	5/16	0.3125	77	7/8-9	49/64	0.7656	76
	O	0.3160	73	25/32	0.7812	65	
	P	0.3230	64	7/8-14	51/64	0.7969	84
3/8-24	21/64	0.3281	87	13/16	0.8125	67	
	Q	0.3320	79	1"-8	55/64	0.8594	87
	R	0.3390	67	7/8	0.8750	77	
	7/16-14	T	0.3580	86	57/64	0.8906	67
23/64		0.3594	84	29/32	0.9062	58	
U		0.3680	75	1"-12	29/32	0.9062	87
3/8		0.3750	67	59/64	0.9219	72	
V		0.3770	65	15/16	0.9375	58	

COOLANT-FED TAPS

TAP DRILL SIZE FORMULAS

$$\text{DRILLED HOLE SIZE} = \text{MAJOR DIAMETER OF THREAD} - \frac{(.01299 \times \text{AMOUNT OF \% OF FULL THREAD})}{(\text{THREADS PER INCH})}$$

$$\% \text{ of FULL THREAD} = \text{THREADS PER INCH} \times \frac{(\text{MAJOR DIA OF THREAD} - \text{TAP DRILL DIAMETER})}{0.01299}$$

SUGGESTED PROCESS FOR TAPPING DIFFICULT TO MACHINE MATERIALS

When tapping difficult to machine materials (such as Inconel, 17-4 pH Stainless, and Hastelloy), the following processing has been used to insure consistency of the final threads and longer tap life:

1. Drill the hole using a slightly undersized tap drill.
2. Bore the hole to the largest allowable diameter to achieve specified percentage of thread, using a 2 flute end mill
3. Tap the hole.

While this adds an extra step to the process, this has been used successfully and may be a viable option. Be sure to check our website at www.coolantfedtooling.com for more technical information



Visit our website at www.coolantfedtooling.com for technical information and our latest product offerings.



THE GEORGE WHALLEY COMPANY

Everything Coolant-Fed

COATED THROW-AWAY SPADE DRILL INSERTS AND HOLDERS



ULTRA HIGH PERFORMANCE COATINGS



IMPROVED PRODUCTIVITY



BROADER RANGE OF APPLICATIONS



COOLANT THRU HOLDERS

Discover our new line of Coated Throw-Away Spade Drill Inserts and Holders. Our inserts are manufactured with ultra high performance coatings which allow for higher speeds & feeds, longer tool life, reduced machining time and improved productivity. Our combination of materials and multi-layered coatings provide for a broader range of applications subsequently reducing your inventory. All of our inserts and holders are competitively priced. We have a large inventory of products in stock now and available for immediate delivery.



SERIES & SIZES

SPADE DRILL INSERT AVAILABILITY

SERIES	DIAMETER SIZES			HIGH SPEED STEEL			SUPER COBALT		PREMIUM COBALT		CARBIDE	
	INCH	METRIC	DECIMAL	M04			T15		M48		K20	
				TiN	TiAlN	TiCN	Ultra-TiN	Life-Coat	Ultra-TiN	Life-Coat	Ultra-TiN	Life-Coat
Y	3/8"-27/64"		0.374 - 0.433				•	•	•	•	•	•
		9.5MM - 11MM					•	•				
Z	7/16"-1/2"		0.437 - 0.500				•	•	•	•	•	•
		11.5MM - 12.5MM					•	•				
0	33/64"-11/16"		0.511 - 0.689				•	•	•	•	•	•
		13MM - 17.5MM					•	•				
1	45/64"-15/16"		0.703 - 0.944	•	•	•	•	•	•	•	•	•
		18MM - 24MM					•	•				
2	31/32"-1-3/8"		0.968 - 1.378	•	•	•	•	•			•	•
		26MM - 35MM					•	•				
3	1-13/32"-1-7/8"		1.406 - 1.875	•	•	•	•	•				
		36MM - 47MM					•	•				
4	1-29/32"-2-9/16"		1.889 - 2.562	•	•	•	•	•				
		48MM - 65MM										
5	2-1/2"-3"		2.500 - 3.000	•	•	•						
		64MM - 76MM										
6	3-1/32"-3-1/2"		3.031 - 3.500	•	•	•						
		78MM - 88MM										
7	3-17/32"-4"		3.531 - 4.000	•	•	•						
		90MM - 100MM										
8	4-1/64"-4-1/2"		4.015 - 4.500	•	•	•						
		106MM - 114MM										

SPADE BLADES & HOLDERS

SPADE DRILL HOLDER AVAILABILITY

INSERT SERIES	A SIZE RANGE	B OVERALL LENGTH	C MAX DEPTH	D FLUTE LENGTH	E SHANK DIA.	F SHANK LENGTH	G PIPE TAP
SHORT LENGTH - STRAIGHT SHANK HOLDERS - STRAIGHT FLUTE							
Y TO 3	0.375" - 1.875"	4-13/32" - 10"	1-1/4" - 4-3/4"	2-1/32" - 6"	3/4" - 1-1/2"	2-3/8" - 4"	1/8" - 1/4"
STANDARD LENGTH - STRAIGHT SHANK HOLDERS - STRAIGHT FLUTE							
Y TO 0.5	0.375" - 0.687"	5-17/32" - 5-11/16"	2-3/8" - 2-1/2"	3-5/32" - 3-5/16"	3/4"	2-3/8"	1/8"
INTERMEDIATE LENGTH - STRAIGHT SHANK HOLDERS - STRAIGHT FLUTE							
1 TO 3	0.703" - 1.875"	8-7/8" - 11-3/4"	4-5/8" - 6-1/2"	5-7/8" - 7-3/4"	1" - 1-1/2"	3" - 4"	1/8"-1/4"

COATING CODES & APPLICATIONS

TiN	ST	Titanium Nitride	Color - Yellow / Gold	Effective Abrasion Wear and Good Lubricity.
TiAlN	SA	Titanium Aluminum Nitride	Color - Violet Gray	High Temperature and Outstanding Wear Resistance.
TiCN	SC	Titanium Carbo Nitride	Color - Blue Gray	Outstanding Wear Resistance.
Ultra-TiN	SU	Ultra-TiN	Color - Deep Gold	High Lubricity, High Temperature and Outstanding Wear Resistance.
Life-Coat	SL	Life-Coat	Color - Violet Gray	Phenomenal Lubricity, High Temperature and Outstanding Wear Resistance.



SPADE DRILL INSERTS • SERIES Y

SERIES SUMMARY	DIAMETER SIZES			HIGH SPEED STEEL			SUPER COBALT		PREMIUM COBALT		CARBIDE	
				M04			T15		M48		K20	
	INCH	METRIC	DECIMAL	TiN	TiAlN	TiCN	Ultra-TiN	Life-Coat	Ultra-TiN	Life-Coat	Ultra-TiN	Life-Coat
Y	3/8"-27/64"		0.3740 - 0.4331				•	•	•	•	•	•
		9.5MM - 11MM					•	•				

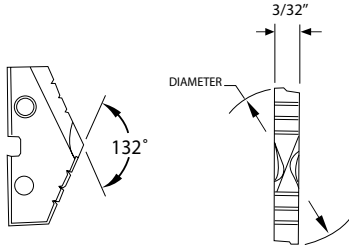

NEW

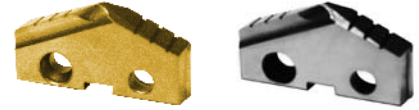

SERIES	DIAMETER SIZES			HIGH SPEED STEEL			SUPER COBALT		PREMIUM COBALT		CARBIDE	
				M04			T15		M48		K20	
	INCH	METRIC	DECIMAL	TiN	TiAlN	TiCN	Ultra-TiN	Life-Coat	Ultra-TiN	Life-Coat	Ultra-TiN	Life-Coat
Y		9.5MM	0.3740				SU001	SL001				
	3/8"		0.3750				SU002	SL002	SU043	SL043	SU462	SL462
		9.8MM	0.3858				SU003	SL003				
	25/64"		0.3906				SU004	SL004	SU045	SL045	SU464	SL464
		10MM	0.3937				SU005	SL005				
		10.2MM	0.4016				SU006	SL006				
	13/32"		0.4063				SU007	SL007	SU048	SL048	SU467	SL467
		10.5MM	0.4134				SU008	SL008				
	27/64"		0.4219				SU009	SL009	SU050	SL050	SU469	SL469
		10.8MM	0.4252				SU010	SL010				
		11MM	0.4331				SU011	SL011				

• Special diameters and alternative coatings available upon request

SPADE DRILL INSERTS • SERIES Z

SERIES SUMMARY	DIAMETER SIZES			HIGH SPEED STEEL			SUPER COBALT		PREMIUM COBALT		CARBIDE	
				M04			T15		M48		K20	
	INCH	METRIC	DECIMAL	TiN	TiAlN	TiCN	Ultra-TiN	Life-Coat	Ultra-TiN	Life-Coat	Ultra-TiN	Life-Coat
Z	7/16"-1/2"		0.4375 - 0.5000				•	•	•	•	•	•
		11.5MM - 12.5MM					•	•				

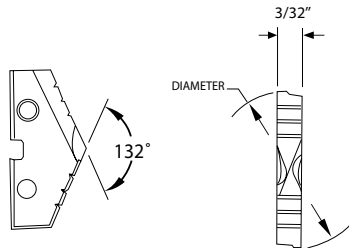

NEW

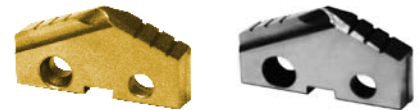

SERIES	DIAMETER SIZES			HIGH SPEED STEEL			SUPER COBALT		PREMIUM COBALT		CARBIDE	
				M04			T15		M48		K20	
	INCH	METRIC	DECIMAL	TiN	TiAlN	TiCN	Ultra-TiN	Life-Coat	Ultra-TiN	Life-Coat	Ultra-TiN	Life-Coat
Z	7/16"		0.4375				SU012	SL012	SU053	SL053	SU472	SL472
		11.5MM	0.4528				SU013	SL013				
	29/64"		0.4531				SU014	SL014	SU055	SL055	SU474	SL474
	15/32"		0.4688				SU015	SL015	SU056	SL056	SU475	SL475
		12MM	0.4724				SU016	SL016				
	31/64"		0.4844				SU017	SL017	SU058	SL058	SU477	SL477
		12.5MM	0.4921				SU018	SL018				
	1/2"		0.5000				SU019	SL019	SU060	SL060	SU479	SL479

• Special diameters and alternative coatings available upon request



SPADE DRILL INSERTS • SERIES 0

SERIES SUMMARY	DIAMETER SIZES			HIGH SPEED STEEL			SUPER COBALT		PREMIUM COBALT		CARBIDE	
				M04			T15		M48		K20	
	INCH	METRIC	DECIMAL	TiN	TiAlN	TiCN	Ultra-TiN	Life-Coat	Ultra-TiN	Life-Coat	Ultra-TiN	Life-Coat
0	33/64"-11/16"		0.5118 - 0.6890				•	•	•	•	•	•
		13MM - 17.5MM					•	•				

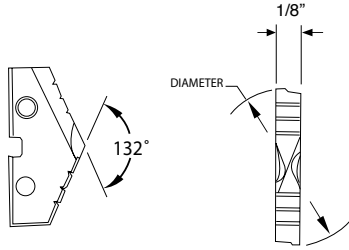

NEW



SERIES	DIAMETER SIZES			HIGH SPEED STEEL			SUPER COBALT		PREMIUM COBALT		CARBIDE	
				M04			T15		M48		K20	
	INCH	METRIC	DECIMAL	TiN	TiAlN	TiCN	Ultra-TiN	Life-Coat	Ultra-TiN	Life-Coat	Ultra-TiN	Life-Coat
0		13MM	0.5118				SU020	SL020				
	33/64"		0.5156				SU021	SL021	SU062	SL062	SU481	SL481
	17/32"		0.5313				SU022	SL022	SU063	SL063	SU482	SL482
		13.5MM	0.5315				SU023	SL023				
	35/64"		0.5469				SU024	SL024	SU065	SL065	SU484	SL484
		14MM	0.5512				SU025	SL025				
	9/16"		0.5625				SU026	SL026	SU067	SL067	SU486	SL486
		14.5MM	0.5709				SU027	SL027				
	37/64"		0.5781				SU028	SL028	SU069	SL069	SU488	SL488
		15MM	0.5906				SU029	SL029				
	19/32"		0.5938				SU030	SL030	SU071	SL071	SU490	SL490
	39/64"		0.6094				SU031	SL031	SU072	SL072	SU491	SL491
		15.5MM	0.6102				SU032	SL032				
	5/8"		0.6250				SU033	SL033	SU074	SL074	SU493	SL493
		16MM	0.6299				SU034	SL034				
	41/64"		0.6406				SU035	SL035	SU076	SL076	SU495	SL495
		16.5MM	0.6496				SU036	SL036				
	21/32"		0.6563				SU037	SL037	SU078	SL078	SU497	SL497
		17MM	0.6693				SU038	SL038				
	43/64"		0.6719				SU039	SL039	SU080	SL080	SU499	SL499
11/16"		0.6875				SU040	SL040	SU081	SL081	SU500	SL500	
	17.5MM	0.6890				SU041	SL041					

SPADE BLADES & HOLDERS

• Special diameters and alternative coatings available upon request



SPADE DRILL INSERTS - SERIES 1

SERIES SUMMARY	DIAMETER SIZES			HIGH SPEED STEEL			SUPER COBALT		PREMIUM COBALT		CARBIDE	
				M04			T15		M48		K20	
	INCH	METRIC	DECIMAL	TiN	TiAlN	TiCN	Ultra-TiN	Life-Coat	Ultra-TiN	Life-Coat	Ultra-TiN	Life-Coat
1	45/64"-15/16"		0.7031 - 0.9449	•	•	•	•	•	•	•	•	•
		18MM - 24MM					•	•				

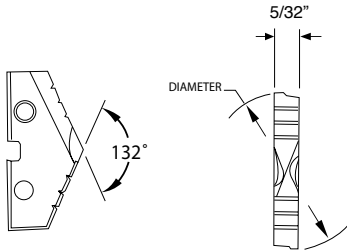

NEW



SERIES	DIAMETER SIZES			HIGH SPEED STEEL			SUPER COBALT		PREMIUM COBALT		CARBIDE	
				M04			T15		M48		K20	
	INCH	METRIC	DECIMAL	TiN	TiAlN	TiCN	Ultra-TiN	Life-Coat	Ultra-TiN	Life-Coat	Ultra-TiN	Life-Coat
1	45/64"		0.7031				SU136	SL136	SU189	SL189	SU502	SL502
		18MM	0.7087				SU137	SL137				
	23/32"		0.7188				SU138	SL138	SU191	SL191	SU504	SL504
		18.5MM	0.7283				SU139	SL139				
	47/64"		0.7344				SU140	SL140	SU193	SL193	SU506	SL506
		19MM	0.7480				SU141	SL141				
	3/4"		0.7500	ST089	SA089	SC089	SU142	SL142	SU195	SL195	SU508	SL508
	49/64"		0.7656	ST090	SA090	SC090	SU143	SL143			SU509	SL509
		19.5M	0.7677				SU144	SL144				
	25/32"		0.7813	ST092	SA092	SC092	SU145	SL145			SU511	SL511
		20MM	0.7874				SU146	SL146				
	51/64"		0.7969	ST094	SA094	SC094	SU147	SL147			SU513	SL513
		20.5MM	0.8071				SU148	SL148				
	13/16"		0.8125	ST096	SA096	SC096	SU149	SL149			SU515	SL515
		21MM	0.8268				SU150	SL150				
	27/32"		0.8438	ST098	SA098	SC098	SU151	SL151			SU517	SL517
	55/64"		0.8594	ST099	SA099	SC099	SU152	SL152			SU518	SL518
		22MM	0.8661				SU153	SL153				
	7/8"		0.8750	ST101	SA101	SC101	SU154	SL154			SU520	SL520
	57/64"		0.8906	ST102	SA102	SC102	SU155	SL155			SU521	SL521
	23MM	0.9055				SU156	SL156					
29/32"		0.9063	ST104	SA104	SC104	SU157	SL157			SU523	SL523	
59/64"		0.9219	ST105	SA105	SC105	SU158	SL158			SU524	SL524	
15/16"		0.9375	ST106	SA106	SC106	SU159	SL159			SU525	SL525	
	24MM	0.9449				SU160	SL160					

• Special diameters and alternative coatings available upon request



SPADE DRILL INSERTS • SERIES 2

SERIES SUMMARY	DIAMETER SIZES			HIGH SPEED STEEL			SUPER COBALT		PREMIUM COBALT		CARBIDE	
				M04			T15		M48		K20	
	INCH	METRIC	DECIMAL	TiN	TiAlN	TiCN	Ultra-TiN	Life-Coat	Ultra-TiN	Life-Coat	Ultra-TiN	Life-Coat
2	31/32"-1-3/8"		0.9688 - 1.3780	•	•	•	•	•			•	•
		26MM - 35MM					•	•				

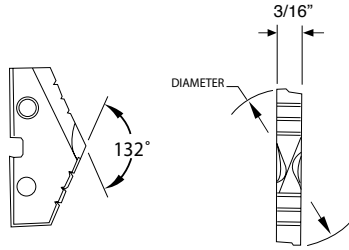

NEW

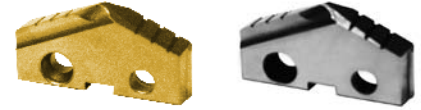

SERIES	DIAMETER SIZES			HIGH SPEED STEEL			SUPER COBALT		PREMIUM COBALT		CARBIDE	
				M04			T15		M48		K20	
	INCH	METRIC	DECIMAL	TiN	TiAlN	TiCN	Ultra-TiN	Life-Coat	Ultra-TiN	Life-Coat	Ultra-TiN	Life-Coat
2	31/32"		0.9688	ST108	SA108	SC108	SU161	SL161			SU527	SL527
	63/64"		0.9844				SU162	SL162			SU528	SL528
	1"		1.0000	ST110	SA110	SC110	SU163	SL163			SU529	SL529
	1-1/64"		1.0156	ST111	SA111	SC111	SU164	SL164			SU530	SL530
		26MM	1.0236				SU165	SL165				
	1-1/32"		1.0313	ST113	SA113	SC113	SU166	SL166			SU532	SL532
	1-3/64"		1.0469	ST114	SA114	SC114	SU167	SL167			SU533	SL533
	1-1/16"		1.0625	ST115	SA115	SC115	SU168	SL168			SU534	SL534
		27MM	1.0630				SU169	SL169				
	1-3/32"		1.0938	ST117	SA117	SC117	SU170	SL170			SU536	SL536
		28MM	1.1024				SU171	SL171				
	1-7/64"		1.1094	ST119	SA119	SC119	SU172	SL172			SU538	SL538
	1-1/8"		1.1250	ST120	SA120	SC120	SU173	SL173			SU539	SL539
		29MM	1.1417				SU174	SL174				
	1-5/32"		1.1563	ST122	SA122	SC122	SU175	SL175			SU541	SL541
		30MM	1.1811				SU176	SL176				
	1-3/16"		1.1875	ST124	SA124	SC124	SU177	SL177			SU543	SL543
	1-7/32"		1.2188	ST125	SA125	SC125	SU178	SL178			SU544	SL544
		31MM	1.2205				SU179	SL179				
	1-1/4"		1.2500	ST127	SA127	SC127	SU180	SL180			SU546	SL546
	32MM	1.2598				SU181	SL181					
1-9/32"		1.2813	ST129	SA129	SC129	SU182	SL182			SU548	SL548	
	33MM	1.2992				SU183	SL183					
1-5/16"		1.3125	ST131	SA131	SC131	SU184	SL184			SU550	SL550	
	34MM	1.3386				SU185	SL185					
1-11/32"		1.3438	ST133	SA133	SC133	SU186	SL186			SU552	SL552	
1-3/8"		1.3750	ST134	SA134	SC134	SU187	SL187			SU553	SL553	
	35MM	1.3780				SU188	SL188					

SPADE BLADES & HOLDERS

• Special diameters and alternative coatings available upon request



SPADE DRILL INSERTS - SERIES 3

SERIES SUMMARY	DIAMETER SIZES			HIGH SPEED STEEL			SUPER COBALT		PREMIUM COBALT		CARBIDE	
				M04			T15		M48		K20	
	INCH	METRIC	DECIMAL	TiN	TiAlN	TiCN	Ultra-TiN	Life-Coat	Ultra-TiN	Life-Coat	Ultra-TiN	Life-Coat
3	1-13/32"-1-7/8"		1.4063- 1.8750	•	•	•	•	•				
		36MM - 47MM					•	•				

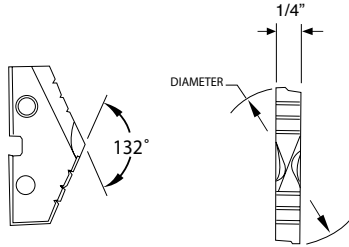

NEW



SERIES	DIAMETER SIZES			HIGH SPEED STEEL			SUPER COBALT		PREMIUM COBALT		CARBIDE	
				M04			T15		M48		K20	
	INCH	METRIC	DECIMAL	TiN	TiAlN	TiCN	Ultra-TiN	Life-Coat	Ultra-TiN	Life-Coat	Ultra-TiN	Life-Coat
3	1-13/32"		1.4063	ST242	SA242	SC242	SU310	SL310				
		36MM	1.4173				SU311	SL311				
	1-7/16"		1.4375	ST244	SA244	SC244	SU312	SL312				
		37MM	1.4567				SU313	SL313				
	1-15/32"		1.4688	ST246	SA246	SC246	SU314	SL314				
		38MM	1.4961				SU315	SL315				
	1-1/2"		1.5000	ST248	SA248	SC248	SU316	SL316				
	1-17/32"		1.5313	ST249	SA249	SC249	SU317	SL317				
		39MM	1.5354				SU318	SL318				
	1-9/16"		1.5625	ST251	SA251	SC251	SU319	SL319				
		40MM	1.5748									
	1-19/32"		1.5938	ST253	SA253	SC253	SU321	SL321				
		41MM	1.6142									
	1-5/8"		1.6250	ST255	SA255	SC255	SU323	SL323				
		42MM	1.6535									
	1-21/32"		1.6563	ST257	SA257	SC257	SU325	SL325				
	1-11/16"		1.6875	ST258	SA258	SC258	SU326	SL326				
		43MM	1.6929									
	1-23/32"		1.7188	ST260	SA260	SC260	SU328	SL328				
		44MM	1.7323									
1-3/4"		1.7500	ST262	SA262	SC262	SU330	SL330					
	45MM	1.7717										
1-25/32"		1.7813	ST264	SA264	SC264	SU332	SL332					
	46MM	1.8110										
1-13/16"		1.8125	ST266	SA266	SC266	SU334	SL334					
1-27/32"		1.8438	ST267	SA267	SC267	SU335	SL335					
	47MM	1.8504										
1-7/8"		1.8750	ST269	SA269	SC269	SU337	SL337					

• Special diameters and alternative coatings available upon request



SPADE DRILL INSERTS • SERIES 4

SERIES SUMMARY	DIAMETER SIZES			HIGH SPEED STEEL			SUPER COBALT		PREMIUM COBALT		CARBIDE	
				M04			T15		M48		K20	
	INCH	METRIC	DECIMAL	TiN	TiAlN	TiCN	Ultra-TiN	Life-Coat	Ultra-TiN	Life-Coat	Ultra-TiN	Life-Coat
4	1-29/32"-2-9/16"		1.8898-2.5625	•	•	•	•	•				
		48MM - 65MM										

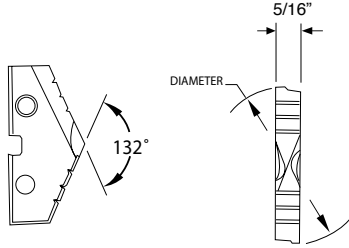

NEW



SERIES	DIAMETER SIZES			HIGH SPEED STEEL			SUPER COBALT		PREMIUM COBALT		CARBIDE	
				M04			T15		M48		K20	
	INCH	METRIC	DECIMAL	TiN	TiAlN	TiCN	Ultra-TiN	Life-Coat	Ultra-TiN	Life-Coat	Ultra-TiN	Life-Coat
4		48MM	1.8898									
	1-29/32"		1.9063	ST271	SA271	SC271	SU339	SL339				
		49MM	1.9291									
	1-15/16"		1.9375	ST273	SA273	SC273	SU341	SL341				
		50MM	1.9685									
	1-31/32"		1.9688	ST275	SA275	SC275	SU343	SL343				
	2"		2.0000	ST276	SA276	SC276	SU344	SL344				
		51MM	2.0079									
	2-1/32"		1.0313	ST278	SA278	SC278	SU346	SL346				
	2-3/64"		2.0469	ST279	SA279	SC279	SU347	SL347				
	2-1/16"		2.0625	ST280	SA280	SC280	SU348	SL348				
		53MM	2.0866									
	2-3/32"		2.0938	ST282	SA282	SC282	SU350	SL350				
	2-1/8"		2.1250	ST283	SA283	SC283	SU351	SL351				
		54MM	2.1260									
	2-5/32"		2.1563	ST285	SA285	SC285	SU353	SL353				
		55MM	2.1654									
	2-3/16"		2.1875	ST287	SA287	SC287	SU355	SL355				
		56MM	2.2047									
	2-7/32"		2.2188	ST289	SA289	SC289	SU357	SL357				
		57MM	2.2441									
	2-1/4"		2.2500	ST291	SA291	SC291	SU359	SL359				
	2-9/32"		2.2813	ST292	SA292	SC292	SU360	SL360				
		58MM	2.2835									
	2-5/16"		2.3125	ST294	SA294	SC294	SU362	SL362				
		59MM	2.3228									
	2-11/32"		2.3438	ST296	SA296	SC296	SU364	SL364				
		60MM	2.3622									
	2-3/8"		2.3750	ST298	SA298	SC298	SU366	SL366				
		61MM	2.4016									
	2-13/32"		2.4063	ST300	SA300	SC300	SU368	SL368				
	2-7/16"		2.4375	ST301	SA301	SC301	SU369	SL369				
	62MM	2.4409										
2-15/32"		2.4688	ST303	SA303	SC303	SU371	SL371					
	63MM	2.4803										
2-1/2"		2.5000	ST305	SA305	SC305	SU373	SL373					
	64MM	2.5197										
2-17/32"		2.5313	ST307	SA307	SC307	SU375	SL375					
	65MM	2.5591										
2-9/16"		2.5625	ST309	SA309	SC309	SU377	SL377					

• Special diameters and alternative coatings available upon request

SPADE BLADES & HOLDERS



SPADE DRILL INSERTS • SERIES 5

SERIES SUMMARY	DIAMETER SIZES			HIGH SPEED STEEL			SUPER COBALT		PREMIUM COBALT		CARBIDE	
				M04			T15		M48		K20	
	INCH	METRIC	DECIMAL	TiN	TiAlN	TiCN	Ultra-TiN	Life-Coat	Ultra-TiN	Life-Coat	Ultra-TiN	Life-Coat
5	2-1/2"-3"		2.5000 - 3.0000	•	•	•						
		64MM - 76MM										

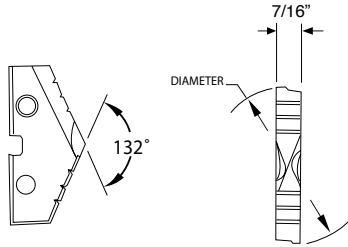

NEW



SERIES	DIAMETER SIZES			HIGH SPEED STEEL			SUPER COBALT		PREMIUM COBALT		CARBIDE	
				M04			T15		M48		K20	
	INCH	METRIC	DECIMAL	TiN	TiAlN	TiCN	Ultra-TiN	Life-Coat	Ultra-TiN	Life-Coat	Ultra-TiN	Life-Coat
5	2-1/2"		2.5000	ST378	SA378	SC378						
		64MM	2.5197									
	2-17/32"		2.5313	ST380	SA380	SC380						
	2-9/16"		2.5625	ST381	SA381	SC381						
	2-19/32"		2.5938	ST382	SA382	SC382						
		66MM	2.5984									
	2-5/8"		2.6250	ST384	SA384	SC384						
	2-21/32"		2.6563	ST385	SA385	SC385						
		68MM	2.6772									
	2-11/16"		2.6875	ST387	SA387	SC387						
	2-23/32"		2.7188	ST388	SA388	SC388						
	2-3/4"		2.7500	ST389	SA389	SC389						
		70MM	2.7559									
	2-25/32"		2.7813	ST391	SA391	SC391						
	2-13/16"		2.8125	ST392	SA392	SC392						
		72MM	2.8346									
	2-27/32"		2.8438	ST394	SA394	SC394						
	2-7/8"		2.8750	ST395	SA395	SC395						
	2-29/32"		2.9063	ST396	SA396	SC396						
		74MM	2.9134									
2-15/16"		2.9375	ST398	SA398	SC398							
2-31/32"		2.9688	ST399	SA399	SC399							
	76MM	2.9921										
3"		3.0000	ST401	SA401	SC401							

• Special diameters and alternative coatings available upon request



SPADE DRILL INSERTS • SERIES 6

SERIES SUMMARY	DIAMETER SIZES			HIGH SPEED STEEL			SUPER COBALT		PREMIUM COBALT		CARBIDE	
				M04			T15		M48		K20	
	INCH	METRIC	DECIMAL	TiN	TiAlN	TiCN	Ultra-TiN	Life-Coat	Ultra-TiN	Life-Coat	Ultra-TiN	Life-Coat
6	3-1/32"-3-1/2"		3.0313 - 3.5000	•	•	•						
		78MM - 88MM										

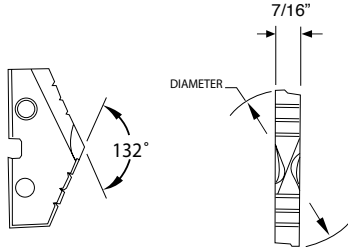

NEW



SERIES	DIAMETER SIZES			HIGH SPEED STEEL			SUPER COBALT		PREMIUM COBALT		CARBIDE	
				M04			T15		M48		K20	
	INCH	METRIC	DECIMAL	TiN	TiAlN	TiCN	Ultra-TiN	Life-Coat	Ultra-TiN	Life-Coat	Ultra-TiN	Life-Coat
6	3-1/32"		3.0313	ST402	SA402	SC402						
	3-1/16"		3.0625	ST403	SA403	SC403						
		78MM	3.0709									
	3-3/32"		3.0938	ST405	SA405	SC405						
	3-1/8"		3.1250	ST406	SA406	SC406						
		80MM	3.1496									
	3-5/32"		3.1563	ST408	SA408	SC408						
	3-3/16"		3.1875	ST409	SA409	SC409						
	3-7/32"		3.2188	ST410	SA410	SC410						
		82MM	3.2283									
	3-1/4"		3.2500	ST412	SA412	SC412						
	3-9/32"		3.2813	ST413	SA413	SC413						
		84MM	3.3071									
	3-5/16"		3.3125	ST415	SA415	SC415						
	3-11/32"		3.3438	ST416	SA416	SC416						
	3-3/8"		3.3750	ST417	SA417	SC417						
		86MM	3.3858									
	3-13/32"		3.4063	ST419	SA419	SC419						
	3-7/16"		3.4375	ST420	SA420	SC420						
		88MM	3.4646									
3-15/32"		3.4688	ST422	SA422	SC422							
3-1/2"		3.5000	ST423	SA423	SC423							

SPADE BLADES & HOLDERS

• Special diameters and alternative coatings available upon request



SPADE DRILL INSERTS • SERIES 7

SERIES SUMMARY	DIAMETER SIZES			HIGH SPEED STEEL			SUPER COBALT		PREMIUM COBALT		CARBIDE	
				M04			T15		M48		K20	
	INCH	METRIC	DECIMAL	TiN	TiAlN	TiCN	Ultra-TiN	Life-Coat	Ultra-TiN	Life-Coat	Ultra-TiN	Life-Coat
7	3-17/32"-4"		3.5313 - 4.0000	•	•	•						
		90MM - 100MM										

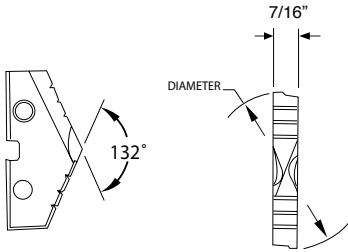

NEW

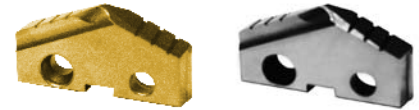

SERIES	DIAMETER SIZES			HIGH SPEED STEEL			SUPER COBALT		PREMIUM COBALT		CARBIDE	
				M04			T15		M48		K20	
	INCH	METRIC	DECIMAL	TiN	TiAlN	TiCN	Ultra-TiN	Life-Coat	Ultra-TiN	Life-Coat	Ultra-TiN	Life-Coat
7	3-17/32"		3.5313	ST424	SA424	SC424						
		90MM	3.5433									
	3-9/16"		3.5625	ST426	SA426	SC426						
	3-19/32"		3.5938	ST427	SA427	SC427						
		92MM	3.6220									
	3-5/8"		3.6250	ST429	SA429	SC429						
	3-21/32"		3.6563	ST430	SA430	SC430						
	3-11/16"		3.6875	ST431	SA431	SC431						
		94MM	3.7008									
	3-23/32"		3.7188	ST433	SA433	SC433						
	3-3/4"		3.7500	ST434	SA434	SC434						
		96MM	3.7795									
	3-25/32"		3.7813	ST436	SA436	SC436						
	3-13/16"		3.8125	ST437	SA437	SC437						
	3-27/32"		3.8438	ST438	SA438	SC438						
		98MM	3.8583									
	3-7/8"		3.8750	ST440	SA440	SC440						
	3-29/32"		3.9063	ST441	SA441	SC441						
	100MM	3.9370										
3-15/16"		3.9375	ST443	SA443	SC443							
3-31/32"		3.9688	ST444	SA444	SC444							
4"		4.0000	ST445	SA445	SC445							

• Special diameters and alternative coatings available upon request



SPADE DRILL INSERTS • SERIES 8

SERIES SUMMARY	DIAMETER SIZES			HIGH SPEED STEEL			SUPER COBALT		PREMIUM COBALT		CARBIDE	
				M04			T15		M48		K20	
	INCH	METRIC	DECIMAL	TiN	TiAlN	TiCN	Ultra-TiN	Life-Coat	Ultra-TiN	Life-Coat	Ultra-TiN	Life-Coat
8	4-1/64"-4-1/2"		4.0156 - 4.5000	•	•	•						
		106MM - 114MM										

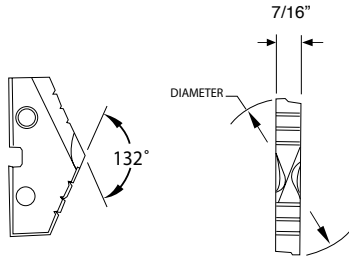

NEW



SERIES	DIAMETER SIZES			HIGH SPEED STEEL			SUPER COBALT		PREMIUM COBALT		CARBIDE	
				M04			T15		M48		K20	
	INCH	METRIC	DECIMAL	TiN	TiAlN	TiCN	Ultra-TiN	Life-Coat	Ultra-TiN	Life-Coat	Ultra-TiN	Life-Coat
8	4-1/64"		4.0156	ST446	SA446	SC446						
	4-1/16"		4.0625	ST447	SA447	SC447						
	4-3/32"		4.0938	ST448	SA448	SC448						
	4-1/8"		4.1250	ST449	SA449	SC449						
		106MM	4.1732									
	4-3/16"		4.1875	ST451	SA451	SC451						
	4-1/4"		4.2500	ST452	SA452	SC452						
		108MM	4.2520									
	4-5/16"		4.3125	ST454	SA454	SC454						
		110MM	4.3307									
	4-3/8"		4.3750	ST456	SA456	SC456						
		112MM	4.4094									
	4-7/16"		4.4375	ST458	SA458	SC458						
		114MM	4.4882									
4-1/2"		4.5000	ST460	SA460	SC460							

SPADE BLADES & HOLDERS

• Special diameters and alternative coatings available upon request



SHORT LENGTH - STRAIGHT SHANK HOLDERS - STRAIGHT FLUTE

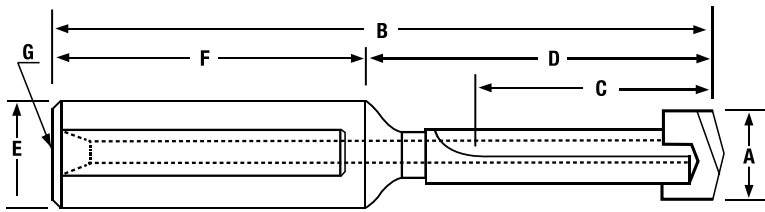

NEW



INSERT SERIES	PART NUMBER	A SIZE RANGE	B OVERALL LENGTH	C MAX. DEPTH	D PROJECTION	E SHANK DIAMETER	F SHANK LENGTH	G PIPE TAP
Y	SH-220Y0S-075L	0.375" - 0.421"	4-13/32"	1-1/4"	2-1/32"	3/4"	2-3/8"	1/8"
Z	SH-220Z0S-075L	0.437" - 0.500"	4-13/32"	1-1/4"	2-1/32"	3/4"	2-3/8"	1/8"
0	SH-22000S-075L	0.515" - 0.687"	4-9/16"	1-3/8"	2-3/16"	3/4"	2-3/8"	1/8"
0.5	SH-22005S-075L	0.609" - 0.687"	4-9/16"	1-3/8"	2-3/16"	3/4"	2-3/8"	1/8"
1	SH-22010S-075L	0.703" - 0.937"	6-7/8"	2-5/8"	3-7/8"	3/4"	3"	1/8"
1	SH-22010S-100L	0.703" - 0.937"	6-7/8"	2-5/8"	3-7/8"	1"	3"	1/8"
1.5	SH-22015S-075L	0.859" - 0.937"	6-7/8"	2-5/8"	3-7/8"	3/4"	3"	1/8"
1.5	SH-22015S-100L	0.859" - 0.937"	6-7/8"	2-5/8"	3-7/8"	1"	3"	1/8"
2	SH-22020S-100L	0.968" - 1.375"	8"	3-3/8"	4-1/2"	1"	3-1/2"	1/8"
2	SH-22020S-125L	0.968" - 1.375"	8"	3-3/8"	4-1/2"	1-1/4"	3-1/2"	1/8"
2.5	SH-22025S-100L	1.187" - 1.375"	8"	3-3/8"	4-1/2"	1"	3-1/2"	1/8"
2.5	SH-22025S-125L	1.187" - 1.375"	8"	3-3/8"	4-1/2"	1-1/4"	3-1/2"	1/8"
3	SH-22030S-125L	1.406" - 1.875"	10"	4-3/4"	6"	1-1/4"	4"	1/4"
3	SH-22030S-150L	1.406" - 1.875"	10"	4-3/4"	6"	1-1/2"	4"	1/4"

STANDARD LENGTH - STRAIGHT SHANK HOLDERS - STRAIGHT FLUTE

INSERT SERIES	PART NUMBER	A SIZE RANGE	B OVERALL LENGTH	C MAX. DEPTH	D PROJECTION	E SHANK DIAMETER	F SHANK LENGTH	G PIPE TAP
Y	SH-240Y0S-075L	0.375" - 0.421"	5-17/32"	2-3/8"	3-5/32"	3/4"	2-3/8"	1/8"
Z	SH-240Z0S-075L	0.437" - 0.500"	5-17/32"	2-3/8"	3-5/32"	3/4"	2-3/8"	1/8"
0	SH-24000S-075L	0.515" - 0.687"	5-11/16"	2-1/2"	3-5/16"	3/4"	2-3/8"	1/8"
0.5	SH-24005S-075L	0.609" - 0.687"	5-11/16"	2-1/2"	3-5/16"	3/4"	2-3/8"	1/8"

INTERMEDIATE LENGTH - STRAIGHT SHANK HOLDERS - STRAIGHT FLUTE

INSERT SERIES	PART NUMBER	A SIZE RANGE	B OVERALL LENGTH	C MAX. DEPTH	D PROJECTION	E SHANK DIAMETER	F SHANK LENGTH	G PIPE TAP
1	SH-23010S-100L	0.703" - 0.937"	8-7/8"	4-5/8"	5-7/8"	1"	3"	1/8"
1.5	SH-23015S-100L	0.859" - 0.937"	8-7/8"	4-5/8"	5-7/8"	1"	3"	1/8"
2	SH-23020S-125L	0.968" - 1.375"	10"	5-3/8"	6-1/2"	1-1/4"	3-1/2"	1/8"
2.5	SH-23025S-125L	1.187" - 1.375"	10"	5-3/8"	6-1/2"	1-1/4"	3-1/2"	1/8"
3	SH-23030S-150L	1.406" - 1.875"	11-3/4"	6-1/2"	7-3/4"	1-1/2"	4"	1/4"



COATING CODES AND APPLICATIONS

TiN	ST	Titanium Nitride	Color - Yellow / Gold	Effective Abrasion Wear and Good Lubricity.
TiAlN	SA	Titanium Aluminum Nitride	Color - Violet Grey	High Temperature and Outstanding Wear Resistance.
TiCN	SC	Titanium Carbo Nitride	Color - Blue Grey	Outstanding Wear Resistance.
Ultra-Tin	SU	Ultra-Tin	Color - Deep Gold	High Lubricity, High Temperature, and Outstanding Wear Resistance.
Life-Coat	SL	Life-Coat	Color - Violet Grey	Phenomenal Lubricity, High Temperature, and Outstanding Wear Resistance.

INTERCHANGEABILITY

GEORGE WHALLEY COMPANY COATINGS			INSERT SUBSTRATE	INTERCHANGES
TiN	ST	Titanium Nitride	M4	TiN
TiAlN	SA	Titanium Aluminum Nitride	M4	TiAlN
TiCN	SC	Titanium Carbo Nitride	M4	TiCN
Ultra-Tin	SU	Ultra-Tin	T15 / M48 / K20	TiN, TiAlN, TiCN
Life-Coat	SL	Life-Coat	T15 / M48 / K20	TiN, TiAlN, TiCN, AM200™

SPADE BLADES & HOLDERS

• The performance of George Whalley Company coatings listed, should meet or exceed those coatings listed as interchanges

• AM200™ is a trademark of Allied Machine & Engineering Corp.

HOLDER CODING

Example:

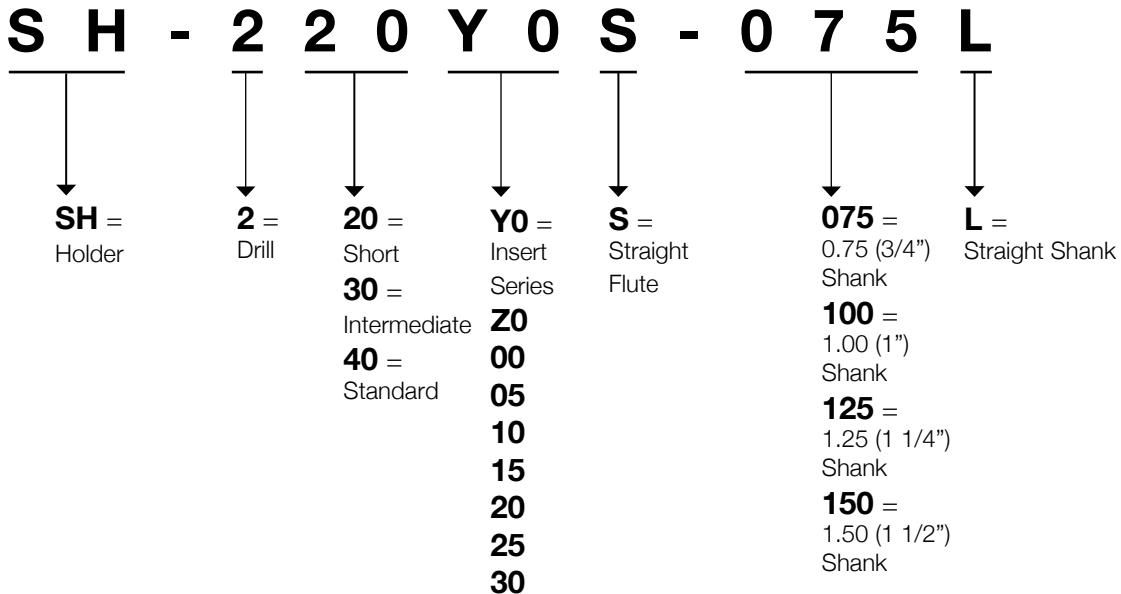



COATED THROW-AWAY SPADE DRILL INSERT SPEED & FEED GUIDELINE

Material	Material Hardness BHN	Insert Substrate	HIGH SPEED STEEL											
			SFM					Feed						
			Coatings					0.375 to 0.500	0.501 to 0.687	0.688 to 0.937	0.938 to 1.375	1.376 to 1.875	1.876 to 2.562	2.563 to 4.500
			M4			T15, M48								
TiN	TiCN	TiAlN	Ultra-TiN	Life-Coat										
Free Machining Steel 1117, 1215, 12L14, etc.	100 - 150	M4 & T15	200	260	280	290	320	0.007	0.010	0.013	0.016	0.020	0.023	0.028
	151 - 200	M4 & T15	180	235	260	270	300	0.007	0.010	0.013	0.016	0.020	0.023	0.028
	201 - 250	M4 & T15	160	210	240	250	280	0.006	0.010	0.013	0.016	0.020	0.023	0.028
Low Carbon Steel 1010, 1020, 1144, etc.	85 - 125	M4 & T15	170	220	250	260	280	0.006	0.009	0.012	0.015	0.019	0.023	0.027
	126 - 175	M4 & T15	160	210	240	250	270	0.006	0.009	0.012	0.015	0.019	0.023	0.027
	176 - 225	M4 & T15	150	195	225	230	250	0.005	0.008	0.010	0.014	0.018	0.021	0.024
	226 - 275	M4 & T15	140	180	210	220	230	0.005	0.008	0.010	0.014	0.018	0.021	0.024
Medium Carbon Steel 1040, 1050, 1140, etc.	125 - 175	M4 & T15	160	210	240	250	270	0.006	0.009	0.012	0.015	0.019	0.023	0.027
	176 - 225	M4 & T15	150	195	225	230	250	0.005	0.008	0.010	0.014	0.018	0.021	0.024
	226 - 275	M4 & T15	140	180	210	220	230	0.005	0.008	0.010	0.014	0.018	0.021	0.024
	276 - 325	T15 & M48	--	--	--	195	220	0.004	0.007	0.009	0.012	0.016	0.019	-
Alloy Steel 4140, 5140, 8620, etc.	125 - 175	M4 & T15	150	195	210	220	230	0.006	0.008	0.010	0.014	0.017	0.019	0.022
	176 - 225	M4 & T15	140	180	195	200	210	0.005	0.008	0.010	0.014	0.017	0.019	0.022
	226 - 275	M4 & T15	130	170	180	190	200	0.005	0.007	0.010	0.014	0.017	0.019	0.022
	276 - 325	T15 & M48	--	--	--	170	190	0.004	0.006	0.009	0.012	0.015	0.017	-
	326 - 375	T15 & M48	--	--	--	155	170	0.003	0.006	0.009	0.012	0.015	0.017	-
High strength Alloy 4340, 4330V, 300M, etc.	225 - 300	T15 & M48	--	--	--	110	115	0.005	0.007	0.009	0.010	0.014	0.017	-
	301 - 350	T15 & M48	--	--	--	85	90	0.004	0.007	0.009	0.010	0.014	0.017	-
	351 - 400	M48	--	--	--	70	70	0.003	0.006	0.008	0.009	0.012	0.015	-
Structural Steel A36, A285, A526, etc.	100 - 150	M4 & T15	140	180	200	210	210	0.006	0.010	0.012	0.014	0.018	0.021	-
	151 - 250	M4 & T15	120	155	170	180	175	0.005	0.009	0.010	0.012	0.016	0.019	-
	251 - 350	T15 & M48	--	--	--	140	150	0.004	0.008	0.009	0.010	0.014	0.017	-
High Temperature Alloy Hastelloy B, Inconel 600, etc.	140 - 220	T15 & M48	--	--	--	40	40	0.003	0.007	0.008	0.010	0.012	0.015	-
	221 - 310	M48	--	--	--	35	35	0.003	0.006	0.007	0.008	0.010	0.012	-
Stainless Steel 303, 416, 420, 17-4PH, etc.	135 - 185	M4 & T15	75	95	105	110	110	0.006	0.008	0.009	0.011	0.014	0.016	0.020
	186 - 275	M4 & T15	60	80	90	95	95	0.005	0.007	0.008	0.010	0.012	0.014	0.018
Tool Steel H13, H21, A4, etc.	150 - 200	T15	--	--	--	110	115	0.004	0.006	0.008	0.010	0.012	0.015	0.017
	201 - 250	T15 & M48	--	--	--	90	100	0.004	0.006	0.008	0.010	0.012	0.015	-
Aluminum	30	M4 & T15	600	750	850	870	--	0.008	0.013	0.016	0.020	0.022	0.025	0.025
	180	M4 & T15	300	400	450	470	--	0.008	0.013	0.016	0.018	0.022	0.025	0.025
Cast Iron Gray, Ductile, Nodular	120 - 150	M4 & T15	170	220	250	260	270	0.007	0.012	0.016	0.020	0.024	0.027	0.030
	151 - 200	M4 & T15	150	195	225	230	250	0.006	0.011	0.014	0.018	0.022	0.025	0.028
	201 - 220	M4 & T15	130	170	195	200	215	0.006	0.009	0.012	0.016	0.018	0.021	0.024
	221 - 260	T15 & M48	--	--	--	165	175	0.005	0.007	0.009	0.012	0.014	0.017	-
	261 - 320	T15 & M48	--	--	--	135	145	0.004	0.006	0.007	0.009	0.012	0.014	-

- These speeds and feeds are offered as guidelines. Equipment, horsepower, rigidity, fixturing, coolant volume and pressure, and material conditions will affect results.
- Overall conditions may require adjustment, up or down, to achieve the best performance.
- When using extended length toolholders reduce the speeds and feeds as depths increase.



COATED THROW-AWAY SPADE DRILL INSERT SPEED & FEED GUIDELINE

Material	Material Hardness BHN	Insert Substrate	CARBIDE						
			SFM		Feed				
			Coatings		0.375 to 0.500	0.501 to 0.687	0.688 to 0.937	0.938 to 1.375	1.376 to 1.875
Ultra-TiN	Life-Coat								
Free Machining Steel 1117, 1215, 12L14, etc.	100 - 150	K20	420	470	0.008	0.012	0.015	0.018	0.021
	151 - 200	K20	360	410	0.007	0.011	0.014	0.016	0.019
	201 - 250	K20	340	380	0.006	0.010	0.013	0.015	0.017
Low Carbon Steel 1010, 1020, 1144, etc.	85 - 125	K20	390	440	0.008	0.010	0.013	0.017	0.019
	126 - 175	K20	340	380	0.007	0.010	0.013	0.016	0.018
	176 - 225	K20	310	350	0.006	0.009	0.012	0.015	0.017
Medium Carbon Steel 1040, 1050, 1140, etc.	226 - 275	K20	270	300	0.005	0.009	0.012	0.015	0.017
	125 - 175	K20	340	380	0.007	0.010	0.013	0.016	0.018
	176 - 225	K20	310	350	0.006	0.009	0.012	0.015	0.017
Alloy Steel 4140, 5140, 8620, etc.	226 - 275	K20	270	300	0.006	0.009	0.012	0.015	0.017
	276 - 325	K20	250	270	0.005	0.008	0.011	0.014	0.016
	326 - 375	K20	220	240	0.004	0.007	0.010	0.013	0.015
High strength Alloy 4340, 4330V, 300M, etc.	225 - 300	K20	200	210	0.006	0.009	0.010	0.012	0.015
	301 - 350	K20	180	190	0.005	0.008	0.009	0.011	0.014
	351 - 400	K20	160	170	0.004	0.007	0.008	0.010	0.012
Structural Steel A36, A285, A526, etc.	100 - 150	K20	310	330	0.008	0.011	0.014	0.016	0.018
	151 - 250	K20	250	260	0.006	0.010	0.012	0.014	0.016
	251 - 350	K20	230	240	0.005	0.009	0.011	0.012	0.014
High Temperature Alloy Hastelloy B, Inconel 600, etc.	140 - 220	K20	105	110	0.004	0.007	0.009	0.011	0.013
	221 - 310	K20	85	90	0.004	0.006	0.008	0.010	0.012
Stainless Steel 303, 416, 420, 17-4PH, etc.	135 - 185	K20	210	220	0.007	0.009	0.012	0.014	0.016
	186 - 275	K20	160	170	0.006	0.008	0.011	0.012	0.014
Tool Steel H13, H21, A4, etc.	150 - 200	K20	220	230	0.004	0.007	0.009	0.011	0.013
	201 - 250	K20	170	180	0.004	0.007	0.009	0.011	0.013
Aluminum	30	K20	1500	--	0.010	0.015	0.018	0.020	0.022
	180	K20	1000	--	0.009	0.013	0.016	0.018	0.020
Cast Iron Gray, Ductile, Nodular	120 - 150	K20	460	475	0.008	0.012	0.015	0.019	0.023
	151 - 200	K20	400	455	0.007	0.011	0.013	0.017	0.021
	201 - 220	K20	360	410	0.006	0.009	0.012	0.015	0.018
	221 - 260	K20	310	340	0.005	0.008	0.011	0.013	0.015
	261 - 320	K20	270	325	0.004	0.007	0.010	0.011	0.013

SPADE BLADES & HOLDERS

- These speeds and feeds are offered as guidelines. Equipment, horsepower, rigidity, fixturing, coolant volume and pressure, and material conditions will affect results.
- Overall conditions may require adjustment, up or down, to achieve the best performance.
- When using extended length toolholders reduce the speeds and feeds as depths increase.



MATERIAL AND COATING PERFORMANCE RECOMMENDATIONS

Material	Material Hardness	HIGH SPEED STEEL			SUPER COBALT		
		BHN	M4			T15	
			TiN	TiCN	TiAlN	Ultra-TiN	Life-Coat
Free Machining Steel 1117, 1215, 12L14, etc.	100 - 150	★☆☆☆☆	★★☆☆☆	★★★★☆	★★★★☆	★★★★★	
	151 - 200	★☆☆☆☆	★★☆☆☆	★★★★☆	★★★★☆	★★★★★	
	201 - 250	★☆☆☆☆	★★☆☆☆	★★★★☆	★★★★☆	★★★★★	
Low Carbon Steel 1010, 1020, 1144, etc.	85 - 125	★☆☆☆☆	★★☆☆☆	★★★★☆	★★★★☆	★★★★★	
	126 - 175	★☆☆☆☆	★★☆☆☆	★★★★☆	★★★★☆	★★★★★	
	176 - 225	★☆☆☆☆	★★☆☆☆	★★★★☆	★★★★☆	★★★★★	
	226 - 275	★☆☆☆☆	★★☆☆☆	★★★★☆	★★★★☆	★★★★★	
Medium Carbon Steel 1040, 1050, 1140, etc.	125 - 175	★☆☆☆☆	★★☆☆☆	★★★★☆	★★★★☆	★★★★★	
	176 - 225	★☆☆☆☆	★★☆☆☆	★★★★☆	★★★★☆	★★★★★	
	226 - 275	★☆☆☆☆	★★☆☆☆	★★★★☆	★★★★☆	★★★★★	
	276 - 325				★★☆☆☆	★★☆☆☆	
Alloy Steel 4140, 5140, 8620, etc.	125 - 175	★☆☆☆☆	★★☆☆☆	★★★★☆	★★★★☆	★★★★★	
	176 - 225	★☆☆☆☆	★★☆☆☆	★★★★☆	★★★★☆	★★★★★	
	226 - 275	★☆☆☆☆	★★☆☆☆	★★★★☆	★★★★☆	★★★★★	
	276 - 325				★★☆☆☆	★★☆☆☆	
	326 - 375				★★☆☆☆	★★☆☆☆	
High Strength Alloy 4340, 4330V, 300M, etc.	225 - 300				★★☆☆☆	★★☆☆☆	
	301 - 350				★★☆☆☆	★★☆☆☆	
	351 - 400						
Structural Steel A36, A285, A526, etc.	100 - 150	★☆☆☆☆	★★☆☆☆	★★★★☆	★★★★☆	★★★★★	
	151 - 250	★☆☆☆☆	★★☆☆☆	★★★★☆	★★★★☆	★★★★★	
	251 - 350				★★☆☆☆	★★☆☆☆	
High Temperature Alloy Hastelloy B, Inconel 600, etc.	140 - 220				★★☆☆☆	★★☆☆☆	
	221 - 310						
Stainless Steel 303, 416, 420, 17-4PH, etc.	135 - 185	★☆☆☆☆	★★☆☆☆	★★★★☆	★★★★☆	★★★★★	
	186 - 275	★☆☆☆☆	★★☆☆☆	★★★★☆	★★★★☆	★★★★★	
Tool Steel H13, H21, A4, etc.	150 - 200				★★★★☆	★★★★★	
	201 - 250				★★☆☆☆	★★☆☆☆	
Aluminum	30	★★☆☆☆	★★☆☆☆	★★★★☆	★★★★★		
	180	★★☆☆☆	★★☆☆☆	★★★★☆	★★★★★		
Cast Iron Gray, Ductile, Nodular	120 - 150	★☆☆☆☆	★★☆☆☆	★★★★☆	★★★★☆	★★★★★	
	151 - 200	★☆☆☆☆	★★☆☆☆	★★★★☆	★★★★☆	★★★★★	
	201 - 220	★☆☆☆☆	★★☆☆☆	★★★★☆	★★★★☆	★★★★★	
	221 - 260				★★☆☆☆	★★☆☆☆	
	261 - 320				★★☆☆☆	★★☆☆☆	

• These materials and coating performance recommendations are offered as guidelines. Equipment, horsepower, rigidity, fixturing, coolant volume and pressure, and material conditions will affect results.



MATERIAL AND COATING PERFORMANCE RECOMMENDATIONS

Material	Material Hardness BHN	PREMIUM COBALT		CARBIDE	
		M48		K20	
		Life-Coat	Life-Coat	Ultra-TiN	Life-Coat
Free Machining Steel 1117, 1215, 12L14, etc.	100 - 150			★★★★☆	★★★★★
	151 - 200			★★★★☆	★★★★★
	201 - 250			★★★★☆	★★★★★
Low Carbon Steel 1010, 1020, 1144, etc.	85 - 125			★★★★☆	★★★★★
	126 - 175			★★★★☆	★★★★★
	176 - 225			★★★★☆	★★★★★
	226 - 275			★★★★☆	★★★★★
Medium Carbon Steel 1040, 1050, 1140, etc.	125 - 175			★★★★☆	★★★★★
	176 - 225			★★★★☆	★★★★★
	226 - 275			★★★★☆	★★★★★
	276 - 325	★★★★☆	★★★★★	★★★★☆	★★★★★
Alloy Steel 4140, 5140, 8620, etc.	125 - 175			★★★★☆	★★★★★
	176 - 225			★★★★☆	★★★★★
	226 - 275			★★★★☆	★★★★★
	276 - 325	★★★★☆	★★★★★	★★★★☆	★★★★★
	326 - 375	★★★★☆	★★★★★	★★★★☆	★★★★★
High Strength Alloy 4340, 4330V, 300M, etc.	225 - 300	★★★★☆	★★★★★	★★★★☆	★★★★★
	301 - 350	★★★★☆	★★★★★	★★★★☆	★★★★★
	351 - 400	★★★★☆	★★★★★	★★★★☆	★★★★★
Structural Steel A36, A285, A526, etc.	100 - 150			★★★★☆	★★★★★
	151 - 250			★★★★☆	★★★★★
	251 - 350	★★★★☆	★★★★★	★★★★☆	★★★★★
High Temperature Alloy Hastelloy B, Inconel 600, etc.	140 - 220	★★★★☆	★★★★★	★★★★☆	★★★★★
	221 - 310	★★★★☆	★★★★★	★★★★☆	★★★★★
Stainless Steel 303, 416, 420, 17-4PH, etc.	135 - 185			★★★★★	★★★★★
	186 - 275			★★★★★	★★★★★
Tool Steel H13, H21, A4, etc.	150 - 200			★★★★☆	★★★★★
	201 - 250	★★★★☆	★★★★★	★★★★☆	★★★★★
Aluminum	30			★★★★★	
	180			★★★★★	
Cast Iron Gray, Ductile, Nodular	120 - 150			★★★★☆	★★★★★
	151 - 200			★★★★☆	★★★★★
	201 - 220			★★★★☆	★★★★★
	221 - 260	★★★★☆	★★★★★	★★★★☆	★★★★★
	261 - 320	★★★★☆	★★★★★	★★★★☆	★★★★★

SPADE BLADES & HOLDERS

M4	T15	M48	K20	TiN	TiCN	TiAlN	Ultra-TiN	Life-Coat	★★★★☆ Good
General Purpose HSS	Heavy cuts in difficult materials	Temp. resistant for high feeds & speeds	Wear resistant w / cutting edge strength	Effective Abrasion Wear and good lubricity	Outstanding wear resistance	High temp. and outstanding wear resistance	High lubricity, high temperature and outstanding wear resistance	Phenomenal lubricity, high temperature, and outstanding wear resistance	★★★★★ Very Good
									★★★★☆ Better
									★★★★☆ Exceptional
									★★★★★ Best



SPADE DRILL BLADES • SERIES MS, A

- Premium CPM-M4 material, better wear resistance, greater tool life.
- Positive lip geometry, reduces horsepower, providing better shearing action.
- Available off the shelf in TiN coating, for quicker delivery and service.
- Shorter projection for better penetration rates.
- Will work with your existing spade drill blade holders.

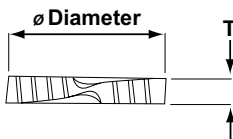
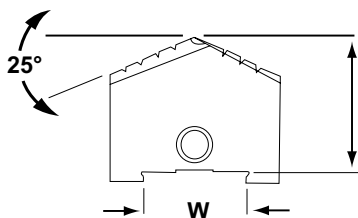

SERIES	DECIMAL DIA. (IN.)	FRACTION DIA. (IN.)	UNCOATED BLADES PART NUMBER	TiN COATED BLADES PART NUMBER
MS L=0.843 T=0.125 W=0.562	0.6720	43/64	*SB-0672MS	*SB-0672MS-T
	0.6870	11/16	*SB-0687MS	*SB-0687MS-T
	0.7180	23/32	*SB-0718MS	*SB-0718MS-T
	0.7500	3/4	*SB-0750MS	*SB-0750MS-T
	0.7810	25/32	*SB-0781MS	*SB-0781MS-T
	0.8120	13/16	*SB-0812MS	*SB-0812MS-T
	0.8430	27/32	*SB-0843MS	*SB-0843MS-T
	0.8750	7/8	*SB-0875MS	*SB-0875MS-T
	0.9060	29/32	*SB-0906MS	*SB-0906MS-T
	0.9370	15/16	*SB-0937MS	*SB-0937MS-T
	0.9680	31/32	*SB-0968MS	*SB-0968MS-T
	1.0000	1	*SB-1000MS	*SB-1000MS-T

* Outgoing Items

SERIES	DECIMAL DIA. (IN.)	FRACTION DIA. (IN.)	UNCOATED BLADES PART NUMBER	TiN COATED BLADES PART NUMBER
A L=0.937 T=0.187 W=0.750	0.9680	31/32	*SB-0968A	*SB-0968A-T
	1.0000	1	*SB-1000A	*SB-1000A-T
	1.0310	1-1/32	*SB-1031A	*SB-1031A-T
	1.0620	1-1/16	*SB-1062A	*SB-1062A-T
	1.0930	1-3/32	*SB-1093A	*SB-1093A-T
	1.1250	1-1/8	*SB-1125A	*SB-1125A-T
	1.1560	1-5/32	*SB-1156A	*SB-1156A-T
	1.1870	1-3/16	*SB-1187A	*SB-1187A-T
	1.2180	1-7/32	*SB-1218A	*SB-1218A-T
	1.2500	1-1/4	*SB-1250A	*SB-1250A-T
	1.2810	1-9/32	*SB-1281A	*SB-1281A-T
	1.3120	1-5/16	*SB-1312A	*SB-1312A-T
	1.3430	1-11/32	*SB-1343A	*SB-1343A-T
	1.3750	1-3/8	*SB-1375A	*SB-1375A-T

* Outgoing Items



SPADE DRILL BLADES • SERIES B, C

- Premium CPM-M4 material, better wear resistance, greater tool life.
- Positive lip geometry, reduces horsepower, providing better shearing action.
- Available off the shelf in TiN coating, for quicker delivery and service.
- Shorter projection for better penetration rates.
- Will work with your existing spade drill blade holders.

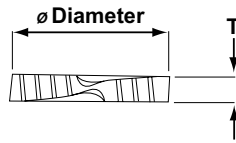
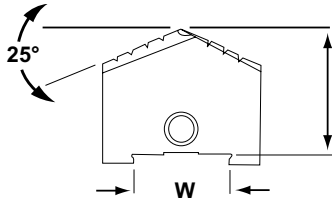

SERIES	DECIMAL DIA. (IN.)	FRACTION DIA. (IN.)	UNCOATED BLADES PART NUMBER	TIN COATED BLADES PART NUMBER
B L=1.125 T=0.281 W=1.062	1.2500	1-1/4	*SB-1250B	*SB-1250B-T
	1.2810	1-9/32	*SB-1281B	*SB-1281B-T
	1.3120	1-5/16	*SB-1312B	*SB-1312B-T
	1.3430	1-11/32	*SB-1343B	*SB-1343B-T
	1.3750	1-3/8	*SB-1375B	*SB-1375B-T
	1.4060	1-13/32	*SB-1406B	*SB-1406B-T
	1.4370	1-7/16	*SB-1437B	*SB-1437B-T
	1.4680	1-15/32	*SB-1468B	*SB-1468B-T
	1.5000	1-1/2	*SB-1500B	*SB-1500B-T
	1.5310	1-17/32	*SB-1531B	*SB-1531B-T
	1.5620	1-9/16	*SB-1562B	*SB-1562B-T
	1.5930	1-19/32	*SB-1593B	*SB-1593B-T
	1.6250	1-5/8	*SB-1625B	*SB-1625B-T
	1.6560	1-21/32	*SB-1656B	*SB-1656B-T
	1.6870	1-11/16	*SB-1687B	*SB-1687B-T
	1.7180	1-23/32	*SB-1718B	*SB-1718B-T
	1.7500	1-3/4	*SB-1750B	*SB-1750B-T

* Outgoing Items

SERIES	DECIMAL DIA. (IN.)	FRACTION DIA. (IN.)	UNCOATED BLADES PART NUMBER	TIN COATED BLADES PART NUMBER
C L=1.562 T=0.312 W=1.250	1.5000	1-1/2	*SB-1500C	*SB-1500C-T
	1.5310	1-17/32	*SB-1531C	*SB-1531C-T
	1.5620	1-9/16	*SB-1562C	*SB-1562C-T
	1.5930	1-19/32	*SB-1593C	*SB-1593C-T
	1.6250	1-5/8	*SB-1625C	*SB-1625C-T
	1.6560	1-21/32	*SB-1656C	*SB-1656C-T
	1.6870	1-11/16	*SB-1687C	*SB-1687C-T
	1.7180	1-23/32	*SB-1718C	*SB-1718C-T
	1.7500	1-3/4	*SB-1750C	*SB-1750C-T
	1.7810	1-25/32	*SB-1781C	*SB-1781C-T
	1.8120	1-13/16	*SB-1812C	*SB-1812C-T
	1.8430	1-27/32	*SB-1843C	*SB-1843C-T
	1.8750	1-7/8	*SB-1875C	*SB-1875C-T
	1.9060	1-29/32	*SB-1906C	*SB-1906C-T
	1.9370	1-15/16	*SB-1937C	*SB-1937C-T
	1.9680	1-31/32	*SB-1968C	*SB-1968C-T
	2.0000	2	*SB-2000C	*SB-2000C-T
	2.0310	2-1/32	*SB-2031C	*SB-2031C-T
	2.0620	2-1/16	*SB-2062C	*SB-2062C-T
	2.0930	2-3/32	*SB-2093C	*SB-2093C-T
	2.1250	2-1/8	*SB-2125C	*SB-2125C-T
	2.1560	2-5/32	*SB-2156C	*SB-2156C-T
	2.1870	2-3/16	*SB-2187C	*SB-2187C-T
	2.2180	2-7/32	*SB-2218C	*SB-2218C-T
	2.2500	2-1/4	*SB-2250C	*SB-2250C-T
	2.2810	2-9/32	*SB-2281C	*SB-2281C-T
	2.3120	2-5/16	*SB-2312C	*SB-2312C-T
	2.3430	2-11/32	*SB-2343C	*SB-2343C-T
2.3750	2-3/8	*SB-2375C	*SB-2375C-T	

* Outgoing Items

SPADE BLADES & HOLDERS



SPADE DRILL BLADES • SERIES D

- Premium CPM-M4 material, better wear resistance, greater tool life.
- Positive lip geometry, reduces horsepower, providing better shearing action.
- Available off the shelf in TiN coating, for quicker delivery and service.
- Shorter projection for better penetration rates.
- Will work with your existing spade drill blade holders.

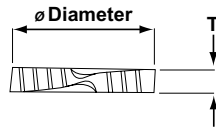
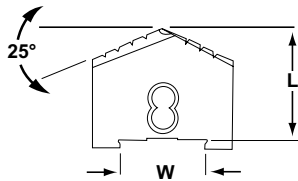

SERIES	DECIMAL DIA. (IN.)	FRACTION DIA. (IN.)	UNCOATED BLADES PART NUMBER	TiN COATED BLADES PART NUMBER
D L=2.000 T=0.375 W=1.750	2.0000	2	*SB-2000D	*SB-2000D-T
	2.0310	2-1/32	*SB-2031D	*SB-2031D-T
	2.0620	2-1/16	*SB-2062D	*SB-2062D-T
	2.0930	2-3/32	*SB-2093D	*SB-2093D-T
	2.1250	2-1/8	*SB-2125D	*SB-2125D-T
	2.1560	2-5/32	*SB-2156D	*SB-2156D-T
	2.1870	2-3/16	*SB-2187D	*SB-2187D-T
	2.2180	2-7/32	*SB-2218D	*SB-2218D-T
	2.2500	2-1/4	*SB-2250D	*SB-2250D-T
	2.2810	2-9/32	*SB-2281D	*SB-2281D-T
	2.3120	2-5/16	*SB-2312D	*SB-2312D-T
	2.3430	2-11/32	*SB-2343D	*SB-2343D-T
	2.3750	2-3/8	*SB-2375D	*SB-2375D-T
	2.4060	2-13/32	*SB-2406D	*SB-2406D-T
	2.4370	2-7/16	*SB-2437D	*SB-2437D-T
	2.4680	2-15/32	*SB-2468D	*SB-2468D-T
	2.5000	2-1/4	*SB-2500D	*SB-2500D-T
	2.5310	2-17/32	*SB-2531D	*SB-2531D-T
	2.5620	2-9/16	*SB-2562D	*SB-2562D-T
	2.5930	2-19/32	*SB-2593D	*SB-2593D-T
	2.6250	2-5/8	*SB-2625D	*SB-2625D-T
	2.6560	2-21/32	*SB-2656D	*SB-2656D-T
	2.6870	2-11/16	*SB-2687D	*SB-2687D-T
	2.7180	2-23/32	*SB-2718D	*SB-2718D-T
	2.7500	2-3/4	*SB-2750D	*SB-2750D-T
	2.7810	2-25/32	*SB-2781D	*SB-2781D-T
	2.8120	2-13/16	*SB-2812D	*SB-2812D-T
	2.8430	2-27/32	*SB-2843D	*SB-2843D-T
	2.8750	2-7/8	*SB-2875D	*SB-2875D-T

* Outgoing Items



SPADE DRILL BLADES • SERIES E

- Premium CPM-M4 material, better wear resistance, greater tool life.
- Positive lip geometry, reduces horsepower, providing better shearing action.
- Available off the shelf in TIN coating, for quicker delivery and service.
- Shorter projection for better penetration rates.
- Will work with your existing spade drill blade holders.

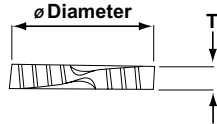
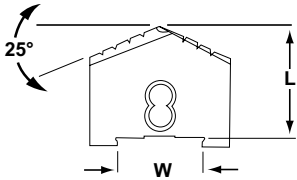

SERIES	DECIMAL DIA. (IN.)	FRACTION DIA. (IN.)	UNCOATED BLADES PART NUMBER	TIN COATED BLADES PART NUMBER
E L=2.375 T=0.437 W=2.062	2.5000	2-1/2	*SB-2500E	*SB-2500E-T
	2.5310	2-17/32	*SB-2531E	*SB-2531E-T
	2.5620	2-9/16	*SB-2562E	*SB-2562E-T
	2.5930	2-19/32	*SB-2593E	*SB-2593E-T
	2.6250	2-5/8	*SB-2625E	*SB-2625E-T
	2.6560	2-21/32	*SB-2656E	*SB-2656E-T
	2.6870	2-11/16	*SB-2687E	*SB-2687E-T
	2.7180	2-23/32	*SB-2718E	*SB-2718E-T
	2.7500	2-3/4	*SB-2750E	*SB-2750E-T
	2.7810	2-25/32	*SB-2781E	*SB-2781E-T
	2.8120	2-13/16	*SB-2812E	*SB-2812E-T
	2.8430	2-27/32	*SB-2843E	*SB-2843E-T
	2.8750	2-7/8	*SB-2875E	*SB-2875E-T
	2.9060	2-29/32	*SB-2906E	*SB-2906E-T
	2.9370	2-15/16	*SB-2937E	*SB-2937E-T
	2.9680	2-31/32	*SB-2968E	*SB-2968E-T
	3.0000	3	*SB-3000E	*SB-3000E-T
	3.0310	3-1/32	*SB-3031E	*SB-3031E-T
	3.0620	3-1/16	*SB-3062E	*SB-3062E-T
	3.0930	3-3/32	*SB-3093E	*SB-3093E-T
	3.1250	3-1/8	*SB-3125E	*SB-3125E-T
	3.1560	3-5/32	*SB-3156E	*SB-3156E-T
	3.1870	3-3/16	*SB-3187E	*SB-3187E-T
	3.2180	3-7/32	*SB-3218E	*SB-3218E-T
	3.2500	3-1/4	*SB-3250E	*SB-3250E-T
	3.2810	3-9/32	*SB-3281E	*SB-3281E-T
	3.3120	3-5/16	*SB-3312E	*SB-3312E-T
	3.3430	3-11/32	*SB-3343E	*SB-3343E-T
	3.3750	3-3/8	*SB-3375E	*SB-3375E-T

* Outgoing Items

SPADE BLADES & HOLDERS



SPADE DRILL BLADES • SERIES F, G

- Premium CPM-M4 material, better wear resistance, greater tool life.
- Positive lip geometry, reduces horsepower, providing better shearing action.
- Available off the shelf in TiN coating, for quicker delivery and service.
- Shorter projection for better penetration rates.
- Will work with your existing spade drill blade holders.

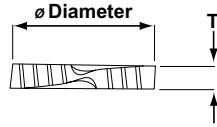
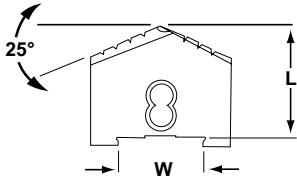

SERIES	DECIMAL DIA. (IN.)	FRACTION DIA. (IN.)	UNCOATED BLADES PART NUMBER	TIN COATED BLADES PART NUMBER
F L=2.875 T=0.500 W=2.625	3.0000	3	*SB-3000F	*SB-3000F-T
	3.0310	3-1/32	*SB-3031F	*SB-3031F-T
	3.0620	3-1/16	*SB-3062F	*SB-3062F-T
	3.0930	3-3/16	*SB-3093F	*SB-3093F-T
	3.1250	3-1/8	*SB-3125F	*SB-3125F-T
	3.1560	3-5/32	*SB-3156F	*SB-3156F-T
	3.1870	3-3/16	*SB-3187F	*SB-3187F-T
	3.2180	3-7/32	*SB-3218F	*SB-3218F-T
	3.2500	3-1/4	*SB-3250F	*SB-3250F-T
	3.2810	3-9/32	*SB-3281F	*SB-3281F-T
	3.3120	3-5/16	*SB-3312F	*SB-3312F-T
	3.3430	3-11/32	*SB-3343F	*SB-3343F-T
	3.3750	3-3/8	*SB-3375F	*SB-3375F-T
	3.4060	3-13/32	*SB-3406F	*SB-3406F-T
	3.4370	3-7/16	*SB-3437F	*SB-3437F-T
	3.4680	3-15/32	*SB-3468F	*SB-3468F-T
	3.5000	3-1/2	*SB-3500F	*SB-3500F-T
	3.5310	3-17/32	*SB-3531F	*SB-3531F-T
	3.5620	3-9/16	*SB-3562F	*SB-3562F-T
	3.5930	3-19/32	*SB-3593F	*SB-3593F-T
	3.6250	3-5/8	*SB-3625F	*SB-3625F-T
	3.6560	3-21/32	*SB-3656F	*SB-3656F-T
	3.6870	3-11/16	*SB-3687F	*SB-3687F-T
	3.7180	3-23/32	*SB-3718F	*SB-3718F-T
	3.7500	3-3/4	*SB-3750F	*SB-3750F-T
	3.7810	3-25/32	*SB-3781F	*SB-3781F-T
	3.8120	3-13/16	*SB-3812F	*SB-3812F-T
	3.8430	3-27/32	*SB-3843F	*SB-3843F-T
	3.8750	3-7/8	*SB-3875F	*SB-3875F-T

* **Outgoing Items**

SERIES	DECIMAL DIA. (IN.)	FRACTION DIA. (IN.)	UNCOATED BLADES PART NUMBER	TIN COATED BLADES PART NUMBER
G L=3.375 T=0.625 W=3.062	3.5000	3-1/2	*SB-3500G	*SB-3500G-T
	3.5310	3-17/32	*SB-3531G	*SB-3531G-T
	3.5620	3-9/16	*SB-3562G	*SB-3562G-T
	3.5930	3-19/32	*SB-3593G	*SB-3593G-T
	3.6250	3-5/8	*SB-3625G	*SB-3625G-T
	3.6560	3-21/32	*SB-3656G	*SB-3656G-T
	3.6870	3-11/16	*SB-3687G	*SB-3687G-T
	3.7180	3-23/32	*SB-3718G	*SB-3718G-T
	3.7500	3-3/4	*SB-3750G	*SB-3750G-T
	3.7810	3-25/32	*SB-3781G	*SB-3781G-T
	3.8120	3-13/16	*SB-3812G	*SB-3812G-T
	3.8430	3-27/32	*SB-3843G	*SB-3843G-T
	3.8750	3-7/8	*SB-3875G	*SB-3875G-T
	3.9060	3-29/32	*SB-3906G	*SB-3906G-T
	3.9370	3-15/16	*SB-3937G	*SB-3937G-T
	3.9680	3-31/32	*SB-3968G	*SB-3968G-T
	4.0000	4	*SB-4000G	*SB-4000G-T
	4.0620	4-1/16	*SB-4062G	*SB-4062G-T
	4.1250	4-1/8	*SB-4125G	*SB-4125G-T
	4.1870	4-3/16	*SB-4187G	*SB-4187G-T
	4.2500	4-1/4	*SB-4250G	*SB-4250G-T
	4.3120	4-5/16	*SB-4312G	*SB-4312G-T
	4.3750	4-3/8	*SB-4375G	*SB-4375G-T

* **Outgoing Items**



SPADE DRILL BLADES • SERIES H

- Premium CPM-M4 material, better wear resistance, greater tool life.
- Positive lip geometry, reduces horsepower, providing better shearing action.
- Available off the shelf in TiN coating, for quicker delivery and service.
- Shorter projection for better penetration rates.
- Will work with your existing spade drill blade holders.

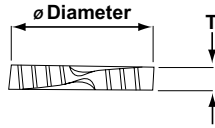
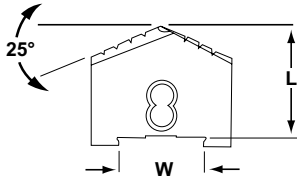

SERIES	DECIMAL DIA. (IN.)	FRACTION DIA. (IN.)	UNCOATED BLADES PART NUMBER	TiN COATED BLADES PART NUMBER
H	4.0000	4	*SB-4000H	*SB-4000H-T
	4.0620	4-1/16	*SB-4062H	*SB-4062H-T
	4.1250	4-1/8	*SB-4125H	*SB-4125H-T
	4.1870	4-3/16	*SB-4187H	*SB-4187H-T
	4.2500	4-1/4	*SB-4250H	*SB-4250H-T
	4.3120	4-5/16	*SB-4312H	*SB-4312H-T
	4.3750	4-3/8	*SB-4375H	*SB-4375H-T
	4.4370	4-7/16	*SB-4437H	*SB-4437H-T
	4.5000	4-1/2	*SB-4500H	*SB-4500H-T
	4.5620	4-9/16	*SB-4562H	*SB-4562H-T
	4.6250	4-5/8	*SB-4625H	*SB-4625H-T
	4.6870	4-11/16	*SB-4687H	*SB-4687H-T
	4.7500	4-3/4	*SB-4750H	*SB-4750H-T
	4.8120	4-13/16	*SB-4812H	*SB-4812H-T
	4.8750	4-7/8	*SB-4875H	*SB-4875H-T
	4.9370	4-15/16	*SB-4937H	*SB-4937H-T
	5.0000	5	*SB-5000H	*SB-5000H-T
	5.1250	5-1/8	*SB-5125H	*SB-5125H-T
	5.2500	5-1/4	*SB-5250H	*SB-5250H-T
	5.3750	5-3/8	*SB-5375H	*SB-5375H-T
	5.5000	5-1/2	*SB-5500H	*SB-5500H-T
	5.6250	5-5/8	*SB-5625H	*SB-5625H-T
	5.7500	5-3/4	*SB-5750H	*SB-5750H-T
	5.8750	5-7/8	*SB-5875H	*SB-5875H-T
	6.0000	6	*SB-6000H	*SB-6000H-T
	6.1250	6-1/8	*SB-6125H	*SB-6125H-T
	6.2500	6-1/4	*SB-6250H	*SB-6250H-T
	6.3750	6-3/8	*SB-6375H	*SB-6375H-T
	6.5000	6-1/2	*SB-6500H	*SB-6500H-T
	6.6250	6-5/8	*SB-6625H	*SB-6625H-T
	6.7500	6-3/4	*SB-6750H	*SB-6750H-T
	6.8750	6-7/8	*SB-6875H	*SB-6875H-T
	7.0000	7	*SB-7000H	*SB-7000H-T
7.1250	7-1/8	*SB-7125H	*SB-7125H-T	
7.2500	7-1/4	*SB-7250H	*SB-7250H-T	
7.3750	7-3/8	*SB-7375H	*SB-7375H-T	

L=3.688
T=0.687
W=3.500

* Outgoing Items

SPADE BLADES & HOLDERS



SPADE DRILL BLADES • FLAT BOTTOM MS, A, B, C, D SERIES

- Premium CPM-M4 material, better wear resistance, greater tool life.
- Positive lip geometry, reduces horsepower, providing better shearing action.
- Available off the shelf in TiN coating, for quicker delivery and service.
- Shorter projection for better penetration rates.
- Will work with your existing spade drill blade holders.

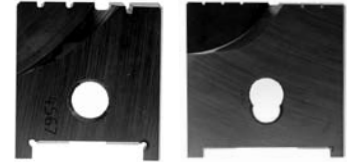
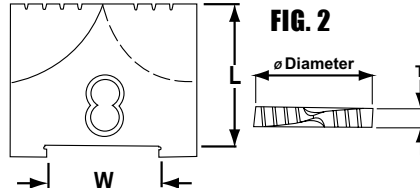
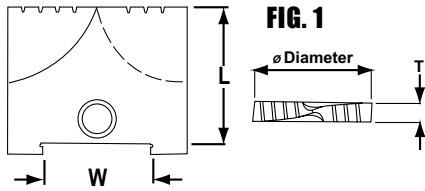

SERIES MS	DECIMAL DIA. (IN.)	FRACTION DIA. (IN.)	PART NUMBER
L=0.843	0.7500	3/4	*FB-0750MS
T=0.125	0.8120	13/16	*FB-0812MS
W=0.562	0.8750	7/8	*FB-0875MS
FIG. 1	0.9370	15/16	*FB-0937MS
	1.0000	1	*FB-1000MS

* Outgoing Items

SERIES A	DECIMAL DIA. (IN.)	FRACTION DIA. (IN.)	PART NUMBER
L=0.937	1.0000	1	*FB-1000A
T=0.187	1.0620	1-1/16	*FB-1062A
W=0.750	1.1870	1-3/16	*FB-1187A
FIG. 1			

* Outgoing Items

SERIES B	DECIMAL DIA. (IN.)	FRACTION DIA. (IN.)	PART NUMBER
L=1.125	1.0000	1	*FB-1000B
T=0.281	1.0620	1-1/16	*FB-1062B
W=1.062	1.1250	1-1/8	*FB-1125B
FIG. 1	1.1870	1-3/16	*FB-1187B
	1.2500	1-1/4	*FB-1250B
	1.3120	1-5/16	*FB-1312B
	1.4370	1-7/16	*FB-1437B

* Outgoing Items

SERIES C	DECIMAL DIA. (IN.)	FRACTION DIA. (IN.)	PART NUMBER
L=1.562	1.8120	1-13/16	*FB-1812C
T=0.312			
W=1.250			
FIG. 2			

* Outgoing Items

SERIES D	DECIMAL DIA. (IN.)	FRACTION DIA. (IN.)	PART NUMBER
L=2.000	2.1250	2-1/8	*FB-2125D
T=0.375	2.1870	2-3/16	*FB-2187D
W=1.750	2.3120	2-5/16	*FB-2312D
FIG. 2	2.3750	2-3/8	*FB-2375D
	2.4370	2-7/16	*FB-2437D
	2.5000	2-1/2	*FB-2500D

* Outgoing Items



SPADE DRILL BLADES • FLAT BOTTOM E, F, G, H SERIES

- Premium CPM-M4 material, better wear resistance, greater tool life.
- Positive lip geometry, reduces horsepower, providing better shearing action.
- Available off the shelf in TiN coating, for quicker delivery and service.
- Shorter projection for better penetration rates.
- Will work with your existing spade drill blade holders.

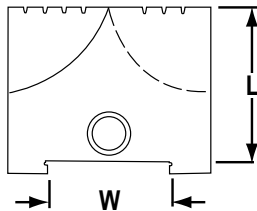

FIG. 1

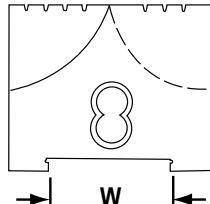
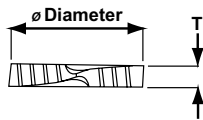
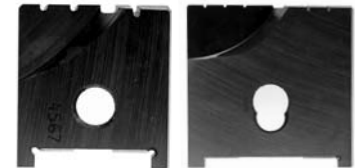
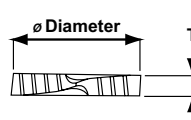

FIG. 2



SPADE BLADES
& HOLDERS

SERIES E L=2.375 T=0.437 W=2.062 FIG. 2	DECIMAL DIA. (IN.)	FRACTION DIA. (IN.)	PART NUMBER
	2.5620	2-9/16	*FB-2562E
	2.6250	2-5/8	*FB-2625E
	2.8120	2-13/16	*FB-2812E
	2.8750	2-7/8	*FB-2875E
	3.0000	3	*FB-3000E

* **Outgoing Items**

SERIES F L=2.875 T=0.500 W=2.625 FIG. 2	DECIMAL DIA. (IN.)	FRACTION DIA. (IN.)	PART NUMBER
	3.1250	3-1/8	*FB-3125F
	3.1870	3-3/16	*FB-3187F
	3.3120	3-5/16	*FB-3312F
	3.4370	3-7/16	*FB-3437F

* **Outgoing Items**

SERIES G L=3.375 T=0.625 W=3.062 FIG. 2	DECIMAL DIA. (IN.)	FRACTION DIA. (IN.)	PART NUMBER
	3.5620	3-9/16	*FB-3562G
	3.6250	3-5/8	*FB-3625G
	3.6870	3-11/16	*FB-3687G
	3.7500	3-3/4	*FB-3750G
	3.8120	3-13/16	*FB-3812G
	3.8750	3-7/8	*FB-3875G
	3.9370	3-15/16	*FB-3937G
	4.0000	4	*FB-4000G

* **Outgoing Items**

SERIES H L=3.688 T=0.687 W=3.500 FIG. 2	DECIMAL DIA. (IN.)	FRACTION DIA. (IN.)	PART NUMBER
	4.1250	4-1/8	*FB-4125H
	4.6250	4-5/8	*FB-4625H
	4.7500	4-3/4	*FB-4750H

* **Outgoing Items**



SPADE BLADE HOLDERS • MINI SERIES • STRAIGHT SHANK • COOLANT : END ENTRY & SIDE ENTRY

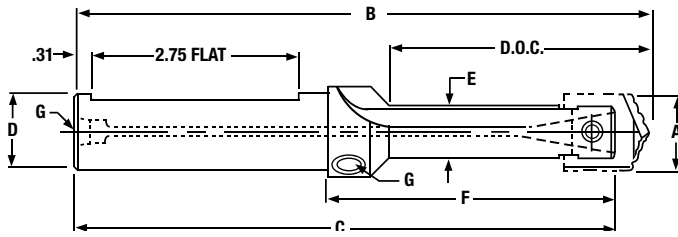

STANDARD

•Spade blades sold separately, beginning on page 64.

PART NUMBER	SERIES	A RANGE	B	C	D SHANK DIA.	E BODY DIA.	D.O.C. MAX.	F	G
SHORT SERIES									
* SBH-MS-001	MS	0.672 to 1.000	7-15/32	7-3/16	1.000	0.650	3-1/8	3-13/16	1/8-27 NPT
MEDIUM SERIES									
* SBH-MS-003	MS	0.672 to 1.000	9-15/32	9-3/16	1.000	0.650	5-1/8	5-13/16	1/8-27 NPT
LONG SERIES									
* SBH-MS-005	MS	0.672 to 1.000	11-15/32	11-3/16	1.000	0.650	7-1/8	7-13/16	1/8-27 NPT

* Outgoing Items

- One pass drilling • No pecking cycle needed • No lost time for chip removal • Chip breakers built into spade blades results in small "C" shaped chips
- Longer tool life • Less heat damage with coolant • Less friction through better lubrication

SPADE BLADE HOLDERS • MINI SERIES • HEAVY DUTY • STRAIGHT SHANK • COOLANT : END ENTRY & SIDE ENTRY

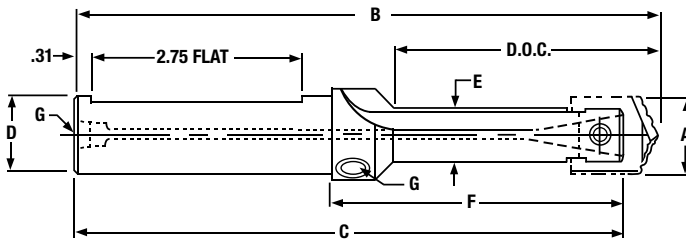

HEAVY DUTY

•Spade blades sold separately, beginning on page 64.

PART NUMBER	SERIES	A RANGE	B	C	D SHANK DIA.	E BODY DIA.	D.O.C. MAX.	F	G
MEDIUM SERIES									
* SBH-MS-004	MS	0.812 to 1.000	9-15/32	9-3/16	1.000	0.687	5-1/8	5-13/16	1/8-27 NPT
LONG SERIES									
* SBH-MS-006	MS	0.812 to 1.000	11-15/32	11-3/16	1.000	0.687	7-1/8	7-13/16	1/8-27 NPT

* Outgoing Items



SPADE BLADE HOLDERS • STRAIGHT SHANK • COOLANT: END ENTRY & SIDE ENTRY

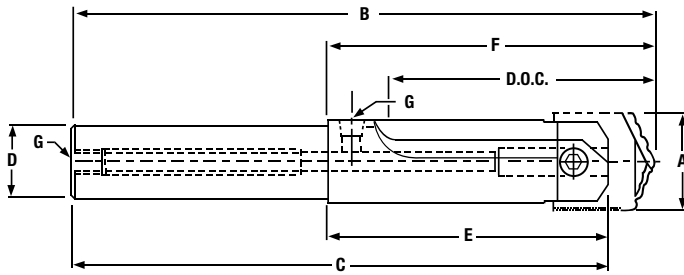

SHORT SERIES

•Spade blades sold separately, beginning on page 64.

PART NUMBER	SERIES	A	B	C	D	E	D.O.C. MAX.	F	G
* 801-003	**A	31/32 to 1-3/8	6-13/16	6-1/2	1	3	2-7/8	3-5/16	1/8 NPT
* 801-005	B	1-1/4 to 1-3/4	7-3/4	7-1/2	1	3-1/2	3-1/4	3-3/4	1/8 NPT
* 801-006	B	1-1/4 to 1-3/4	7-3/4	7-1/2	1-1/2	3-1/2	3-1/4	3-3/4	1/8 NPT
* 801-009	D	2 to 2-7/8	8-5/8	8	1-1/2	4	4-1/8	4-5/8	1/4 NPT
* 801-010	D	2 to 2-7/8	8-5/8	8	1-3/4	4	4-1/8	4-5/8	1/4 NPT
* 801-011	E	2-1/2 to 3-3/8	9-13/16	9	1-3/4	5	5-3/8	5-13/16	1/4 NPT
* 801-012	E	2-1/2 to 3-3/8	9-13/16	9	2	5	5-3/8	5-13/16	1/4 NPT
* 801-013	F	3 to 3-7/8	11	10	2	6	6-1/2	7	3/8 NPT
* 801-014	F	3 to 3-7/8	11	10	2-1/2	6	6-1/2	7	3/8 NPT
* 801-115	G	3-1/2 to 4-1/2	12-7/16	11	3	6	7	7-7/16	1/2 NPT

* Outgoing Items

SPADE BLADES & HOLDERS

LONG SERIES

•Spade blades sold separately, beginning on page 64.

PART NUMBER	SERIES	A	B	C	D	E	D.O.C. MAX.	F	G
* 801-015	AA	31/32 to 1-3/8	11-3/4	11-1/4	1	7-3/4	7-3/4	8-1/4	1/8 NPT
* 801-016	AA	31/32 to 1-3/8	11-3/4	11-1/4	1-1/2	7-3/4	7-3/4	8-1/4	1/8 NPT
* 801-017	**A	31/32 to 1-3/8	11-9/16	11-1/4	1	7-3/4	7-5/8	8-1/16	1/8 NPT
* 801-018	**A	31/32 to 1-3/8	11-9/16	11-1/4	1-1/2	7-3/4	7-5/8	8-1/16	1/8 NPT
* 801-019	B	1-1/4 to 1-3/4	12-3/8	12-1/8	1-1/4	8-1/8	7-7/8	8-3/8	1/8 NPT
* 801-020	B	1-1/4 to 1-3/4	12-3/8	12-1/8	1-1/2	8-1/8	7-7/8	8-3/8	1/8 NPT
* 801-021	C	1-1/2 to 2-3/8	12-15/16	12-1/2	1-1/2	8-1/2	8-1/2	8-15/16	1/8 NPT
* 801-023	E	2-1/2 to 3-3/8	15-1/16	14-1/4	2	10-1/4	10-5/8	11-1/16	1/4 NPT
* 801-025	G	3-1/2 to 4-1/2	19-15/16	18-1/2	3	13-1/2	14-1/2	14-15/16	1/2 NPT
* 801-026	H	4 to 8	23-1/16	21-1/2	3	15-1/2	16-5/8	17-1/16	1/2 NPT

* Outgoing Items

**Note : "A" series holders accept blades 3/16" thick. For blades 1/4" thick, order holders series "AA"



SPADE BLADE HOLDERS • STRAIGHT SHANK • COOLANT : END ENTRY & SIDE ENTRY

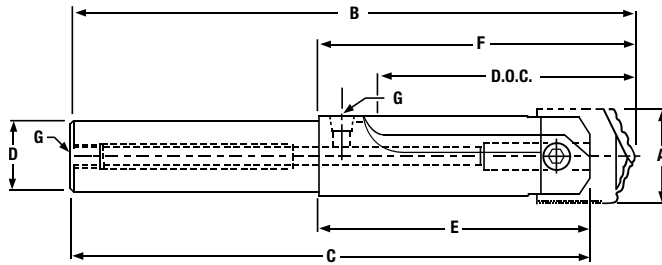

EXTRA LONG SERIES

•Spade blades sold separately, beginning on page 64.

PART NUMBER	SERIES	A	B	C	D	E	D.O.C. MAX.	F	G
* 801-127	A	31/32 to 1-3/8	14-9/16	14-3/4	1-1/2	11-1/4	11-1/8	11-9/16	1/8 NPT
* 801-128	B	1-1/4 to 1-3/4	15-1/2	15-1/4	1-1/2	11-1/4	11	11-1/2	1/8 NPT
* 801-129	C	1-1/2 to 2-3/8	17-7/16	17	1-1/2	13	13	13-7/16	1/8 NPT
* 801-130	D	2 to 2-7/8	17-1/2	17	1-3/4	13	13-1/8	13-1/2	1/4 NPT
* 801-131	E	2-1/2 to 3-3/8	18-13/16	18	2	14	14-3/8	14-13/16	1/4 NPT

* **Outgoing Items**

SPADE BLADE HOLDERS • TAPER SHANK • COOLANT : SIDE ENTRY ON MORSE TAPER

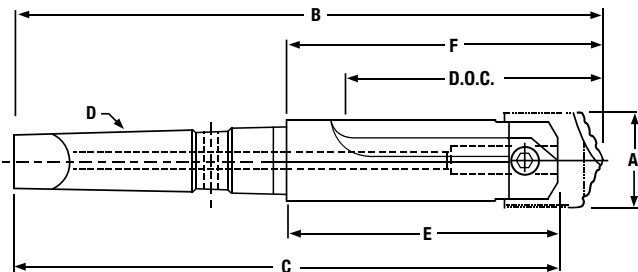

SHORT SERIES

•Spade blades sold separately, beginning on page 64.

PART NUMBER	SERIES	A	B	C	D	E	D.O.C. MAX.	F
* 801-027	AA	31/32 to 1-3/8	7-3/8	6-7/8	#3	3	3-1/8	3-1/2
* 801-028	**A	31/32 to 1-3/8	7-3/16	6-7/8	#3	3	2-7/8	3-5/16
* 801-029	B	1-1/4 to 1-3/4	8-5/8	8-3/8	#4	3-1/2	3-1/4	3-3/4
* 801-030	C	1-1/2 to 2-3/8	8-13/16	8-3/8	#4	3-1/2	3-1/2	3-15/16
* 801-031	D	2 to 2-7/8	9-1/2	8-7/8	#4	4	4-1/8	4-5/8
* 801-032	E	2-1/2 to 3-3/8	11-15/16	11-1/8	#5	5	5-3/8	5-13/16

* **Outgoing Items**

**Note : "A" series holders accept blades 3/16" thick. For blades 1/4" thick, order holders series "AA"



SPADE BLADE HOLDERS TAPER SHANK • COOLANT: SIDE ENTRY • PROVISION FOR OPTIONAL ROTARY COOLANT GLAND

Spade blade holders DO NOT include Rotary Coolant Glands. To order Rotary Coolant Glands, see pages 112-113.

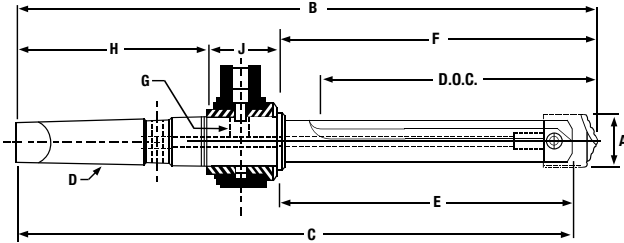

OPTIONAL

SHORT SERIES

•Spade blades sold separately, beginning on page 64.



PART NUMBER	SERIES	A	B	C	D MT	E	D.O.C. MAX.	F	G	H	J	ROTARY COOLANT GLAND
* 801-036	A	31/32 to 1-3/8	10-1/16	9-3/4	#4	3	2-7/8	3-5/16	1/4 NPT	4-7/8	1-7/8	CGH2-1250
* 801-037	B	1-1/4 to 1-3/4	10-1/2	10-1/4	#4	3-1/2	3-1/4	3-3/4	1/4 NPT	4-7/8	1-7/8	CGH2-1250
* 801-038	C	1-1/2 to 2-3/8	11-3/16	10-3/4	#4	4	4	4-7/16	1/4 NPT	4-7/8	1-7/8	CGH2-1250
* 801-039	D	2 to 2-7/8	11-7/8	11-1/4	#4	4-1/2	4-5/8	5-1/8	3/8 NPT	4-7/8	1-7/8	CGH2-1500
* 801-040	E	2-1/2 to 3-3/8	14-3/16	13-3/8	#5	5	5-3/8	5-13/16	3/8 NPT	6-1/8	2-1/4	CGH2-2000
* 801-041	F	3 to 3-7/8	14-7/8	13-7/8	#5	5-1/2	6	6-1/2	3/8 NPT	6-1/8	2-1/4	CGH2-2000
* 801-043	H	4 to 8	20-1/8	18-9/16	#6	7	8-1/8	8-9/16	1/2 NPT	8-9/16	3	CGH2-2562

* Outgoing Items

OPTIONAL

MEDIUM SERIES

•Spade blades sold separately, beginning on page 64.



PART NUMBER	SERIES	A	B	C	D MT	E	D.O.C. MAX.	F	G	H	J	ROTARY COOLANT GLAND
* 801-044	AA	31/32 to 1-3/8	15	14-1/2	#4	7-3/4	7-3/4	8-1/4	1/4 NPT	4-7/8	1-7/8	CGH2-1250
* 801-045	**A	31/32 to 1-3/8	14-13/16	14-1/2	#4	7-3/4	7-5/8	8-1/16	1/4 NPT	4-7/8	1-7/8	CGH2-1250
* 801-046	B	1-1/4 to 1-3/4	15-1/8	14-7/8	#4	8-1/8	7-7/8	8-3/8	1/4 NPT	4-7/8	1-7/8	CGH2-1250
* 801-047	C	1-1/2 to 2-3/8	15-11/16	15-1/4	#4	8-1/2	8-1/2	8-15/16	1/4 NPT	4-7/8	1-7/8	CGH2-1250
* 801-048	D	2 to 2-7/8	16-13/16	16-3/16	#4	9-1/4	9-3/8	9-7/8	3/8 NPT	4-7/8	2-1/16	CGH2-1500
* 801-049	E	2-1/2 to 3-3/8	19-7/16	18-5/8	#5	10-1/4	10-1/2	11-1/16	3/8 NPT	6-1/8	2-1/4	CGH2-2000
* 801-050	F	3 to 3-7/8	21-1/8	20-1/8	#5	11-3/4	12-1/4	12-3/4	3/8 NPT	6-1/8	2-1/4	CGH2-2000
* 801-051	G	3-1/2 to 4-1/2	23-5/16	21-7/8	#5	13-1/2	14-1/2	14-15/16	3/8NPT	6-1/8	2-1/4	CGH2-2000
* 801-052	H	4 to 8	28-5/8	27-1/16	#6	15-1/2	16-5/8	17-1/16	1/2 NPT	8-9/16	3	CGH2-2562

* Outgoing Items

**Note : "A" series holders accept blades 3/16" thick. For blades 1/4" thick, order holders series "AA"

OPTIONAL

LONG SERIES

•Spade blades sold separately, beginning on page 64.



PART NUMBER	SERIES	A	B	C	D MT	E	D.O.C. MAX.	F	G	H	J	ROTARY COOLANT GLAND
* 801-145	A	31/32 to 1-3/8	18-5/16	18	#4	11-1/4	11-1/8	11-9/16	1/4 NPT	4-7/8	1-7/8	CGH2-1250
* 801-146	B	1-1/4 to 1-3/4	18-1/4	18	#4	11-1/4	11	11-1/2	1/4 NPT	4-7/8	1-7/8	CGH2-1250
* 801-147	C	1-1/2 to 2-3/8	20-3/16	19-3/4	#4	13	13	13-7/16	1/4 NPT	4-7/8	1-7/8	CGH2-1250
* 801-148	D	2 to 2-7/8	20-9/16	19-15/16	#4	13	13-1/8	13-5/8	3/8 NPT	4-7/8	2-1/16	CGH2-1500
* 801-149	E	2-1/2 to 3-3/8	23-3/16	22-3/8	#5	14	14-3/8	14-13/16	3/8 NPT	6-1/8	2-1/4	CGH2-2000

* Outgoing Items



SPADE BLADE HOLDERS • TAPER SHANK • COOLANT: SIDE ENTRY • PROVISION FOR OPTIONAL ROTARY COOLANT GLAND

• Spade blade holders DO NOT include Rotary Coolant Glands. To order Rotary Coolant Glands, see pages 112-113.

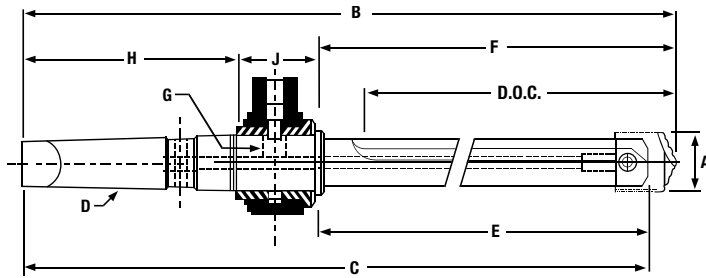

OPTIONAL

EXTRA LONG SERIES

• Spade blades sold separately, beginning on page 64.



PART NUMBER	SERIES	A	B	C	D MT	E	D.O.C. MAX.	F	G	H	J	ROTARY COOLANT GLAND
*801-053	AA	31/32 to 1-3/8	22-1/4	21-3/4	#4	15	15-1/8	15-1/2	1/4 NPT	4-7/8	1-7/8	CGH2-1250
*801-054	**A	31/32 to 1-3/8	22-1/16	21-3/4	#4	15	14-7/8	15-5/16	1/4 NPT	4-7/8	1-7/8	CGH2-1250
*801-055	B	1-1/4 to 1-3/4	22	21-3/4	#4	15	14-3/4	15-1/4	1/4 NPT	4-7/8	1-7/8	CGH2-1250
*801-056	C	1-1/2 to 2-3/8	25-3/16	24-3/4	#4	18	18	18-7/16	1/4 NPT	4-7/8	1-7/8	CGH2-1250
*801-057	D	2 to 2-7/8	25-9/16	24-15/16	#4	18	18-1/8	18-5/8	3/8 NPT	4-7/8	2-1/16	CGH2-1500
*801-058	E	2-1/2 to 3-3/8	29-3/16	28-3/8	#5	20	20-3/8	20-13/16	3/8 NPT	6-1/8	2-1/4	CGH2-2000
*801-059	F	3 to 3-7/8	29-3/8	28-3/8	#5	20	20-1/2	21	3/8 NPT	6-1/8	2-1/4	CGH2-2000
*801-061	H	4 to 8	37-1/8	35-9/16	#6	24	25-1/8	25-9/16	1/2 NPT	8-9/16	3	CGH2-2562

* Outgoing Items

**Note : "A" series holders accept blades 3/16" thick. For blades 1/4" thick, order holders series "AA"

OPTIONAL

SUPER LONG SERIES

• Spade blades sold separately, beginning on page 64.



PART NUMBER	SERIES	A	B	C	D MT	E	D.O.C. MAX.	F	G	H	J	ROTARY COOLANT GLAND
*801-062	A	31/32 to 1-3/8	28-1/16	27-3/4	#4	21	20-7/8	21-5/16	1/4 NPT	4-7/8	1-7/8	CGH2-1250
*801-063	B	1-1/4 to 1-3/4	29	28-3/4	#4	22	21-3/4	22-1/4	1/4 NPT	4-7/8	1-7/8	CGH2-1250
*801-064	C	1-1/2 to 2-3/8	33-3/16	32-3/4	#4	26	26	26-7/16	1/4 NPT	4-7/8	1-7/8	CGH2-1250
*801-065	D	2 to 2-7/8	35-9/16	34-15/16	#4	28	28-1/8	28-5/8	3/8 NPT	4-7/8	2-1/16	CGH2-1500
*801-067	F	3 to 3-7/8	42-3/8	41-3/8	#5	33	33-1/2	34	3/8 NPT	6-1/8	2-1/4	CGH2-2000
*801-068	G	3-1/2 to 4-1/2	46-13/16	45-3/8	#5	37	38	38-7/16	3/8 NPT	6-1/8	2-1/4	CGH2-2000
*801-069	H	4 to 8	49-15/16	48-3/8	#5	40	41-1/8	41-9/16	1/2 NPT	6-1/8	2-1/4	CGH2-2000
*801-070	H	4 to 8	53-1/8	51-9/16	#6	40	41-1/8	41-9/16	1/2 NPT	8-9/16	3	CGH2-2562

* Outgoing Items



SPADE BLADE HOLDERS • 50 NMTB • TAPER SHANK • COOLANT: SIDE ENTRY • PROVISION FOR OPTIONAL ROTARY COOLANT GLAND

• Spade blade holders DO NOT include Rotary Coolant Glands. To order Rotary Coolant Glands, see pages 112-113.

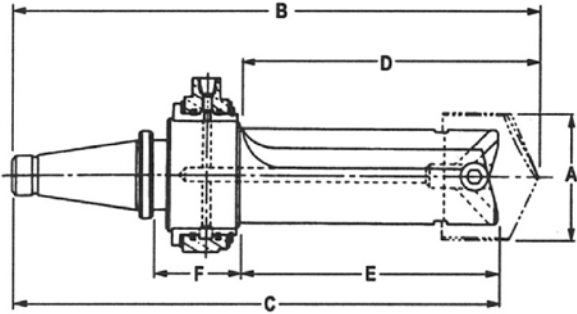

OPTIONAL

• Spade blades sold separately, beginning on page 64.



PART NUMBER	SERIES	A	B	C	D	E	F	ROTARY COOLANT GLAND
*801-200	AA	31/32 to 1-3/8	17-3/4	16-5/8	8	8-1/2	3-21/32	CGH2-2562
*801-201	**A	31/32 to 1-3/8	17-9/16	16-5/8	8	8-5/16	3-21/32	CGH2-2562
*801-202	B	1-1/4 to 1-3/4	17-3/4	16-5/8	8	8-1/2	3-21/32	CGH2-2562
*801-204	D	2 to 2-7/8	20-3/8	18-3/8	10	11-1/8	3-21/32	CGH2-2562
*801-205	E	2-1/2 to 3-3/8	20-9/16	18-3/16	10	11-5/16	3-21/32	CGH2-2562
*801-206	F	3 to 3-7/8	21-15/16	19-1/16	11	12-7/16	3-29/32	CGH2-4250
*801-208	H	4 to 8	23-9/16	19-7/8	12	14-1/16	3-29/32	CGH2-4250

* Outgoing Items

**Note : "A" series holders accept blades 3/16" thick. For blades 1/4" thick, order holders series "AA"

SPADE BLADES & HOLDERS

SPADE BLADE HOLDERS • AUTOMOTIVE SERIES • COOLANT: END ENTRY

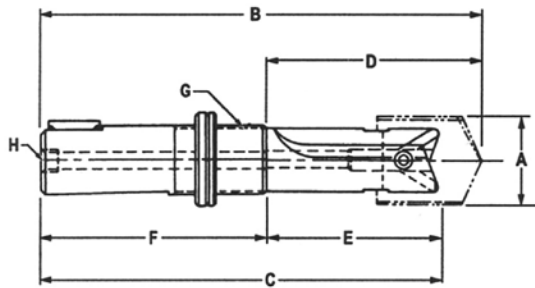

• Spade blades sold separately, beginning on page 64.

PART NUMBER	SERIES	A	B	C	D	E	F	G	H
*801-210	A	31/32 to 1-3/8	12-7/16	11-1/2	6-7/16	5-1/2	6	1-3/8-12	1/8 NPT
*801-211	B	1-1/4 to 1-3/4	12-5/8	11-1/2	6-5/8	5-1/2	6	1-3/8-12	1/8 NPT
*801-212	C	1-1/2 to 2-3/8	13-1/16	11-1/2	7-1/16	5-1/2	6	1-3/8-12	1/8 NPT
*801-213	D	2 to 2-7/8	13-1/2	11-1/2	7-1/2	5-1/2	6	1-7/8-12	1/4 NPT
*801-214	E	2-1/2 to 3-3/8	13-7/8	11-1/2	7-7/8	5-1/2	6	1-7/8-12	1/4 NPT
*801-215	F	3 to 3-7/8	14-3/8	11-1/2	8-3/8	5-1/2	6	1-7/8-12	3/8 NPT
*801-216	G	3-1/2 to 4-1/2	14-7/8	11-1/2	8-7/8	5-1/2	6	1-7/8-12	1/2 NPT
*801-217	H	4 to 8	15-3/16	11-1/2	9-3/16	5-1/2	6	1-7/8-12	1/2 NPT

* Outgoing Items



ADVANTAGES AND INTRODUCTION TO AUTOMATIC TOOL CHANGE COOLANT RETROFIT SYSTEMS

TOOLHOLDER VARIETY

Our selection of standard holders includes V-Flange and BT Shanks. The types of holders available include single and double angle collet chucks, end mill holders, morse taper and ABS® modular holders. Special application holders can be designed to meet your specifications.

TOOLHOLDER VERSATILITY

The same toolholder may be used for:
1. Automatic rotary induced coolant operation
2. Manual rotary induced coolant operation.

MAXIMUM CLEARANCE

Our compact design allows for trouble free tool change operations as well as maximum tool pocket clearance.

EASY MAINTENANCE

Simplicity of design and ease of assembly and disassembly allows for quick, economical maintenance.

ADAPTABILITY

The ATC Retrofit System can be easily adapted to most domestic and imported machines and is interchangeable with most competitive tooling systems.

TOOLHOLDER POSITIONING

ATC toolholders are equipped with a fully adjustable orientation ring.

TOOL EFFICIENCY

The light weight of the adapter and coolant gland allows for maximum cutting tool weight.

PROLONG TOOL LIFE

Cutting tool life is increased by applying coolant-thru-the-tool to prevent heat at the cutting edge, thus reducing premature tool chipping and tool breakage.

IMPROVED PRODUCTION

Coolant-thru-the-tool allows for increased speeds and feeds, improving surface finish and overall performance.

VALUE

Point for point, feature for feature, The George Whalley Company ATC System for coolant-fed tooling, is the most economically priced and easily adapted system available.



INTRODUCTION TO AUTOMATIC TOOL CHANGE (ATC) RETROFIT SYSTEM

The George Whalley Company Automatic Tool Change (ATC) Retrofit System is available to users of CNC machining centers with magazine or matrix-type tool storage features. The ATC Retrofit System eliminates the need for manual loading of coolant-fed tooling when high speed unattended operation is desired.

The ATC Retrofit System consists of a specially designed coolant-thru-the-tool holder assembled with an ATC Rotary Coolant Gland. The gland, which is mounted in an aluminum base assembly, is a uniquely designed bronze wear bushing incorporated with a special double seal only found in The George Whalley ATC Rotary Coolant Gland. The seal is self-lubricating, high heat and wear resistant making it the rotary coolant gland of choice in many manufacturing facilities throughout the metal working industry. ATC Rotary Coolant Glands are supplied in face seal and single or dual pin O-ring seal configurations, designed to fit many of today's popular machining centers. The Manual ATC Style Rotary Coolant Gland is a cost effective alternative when evaluating machine feasibility. These glands can be upgraded easily to ATC Rotary Coolant Glands without having to purchase new tootholders.

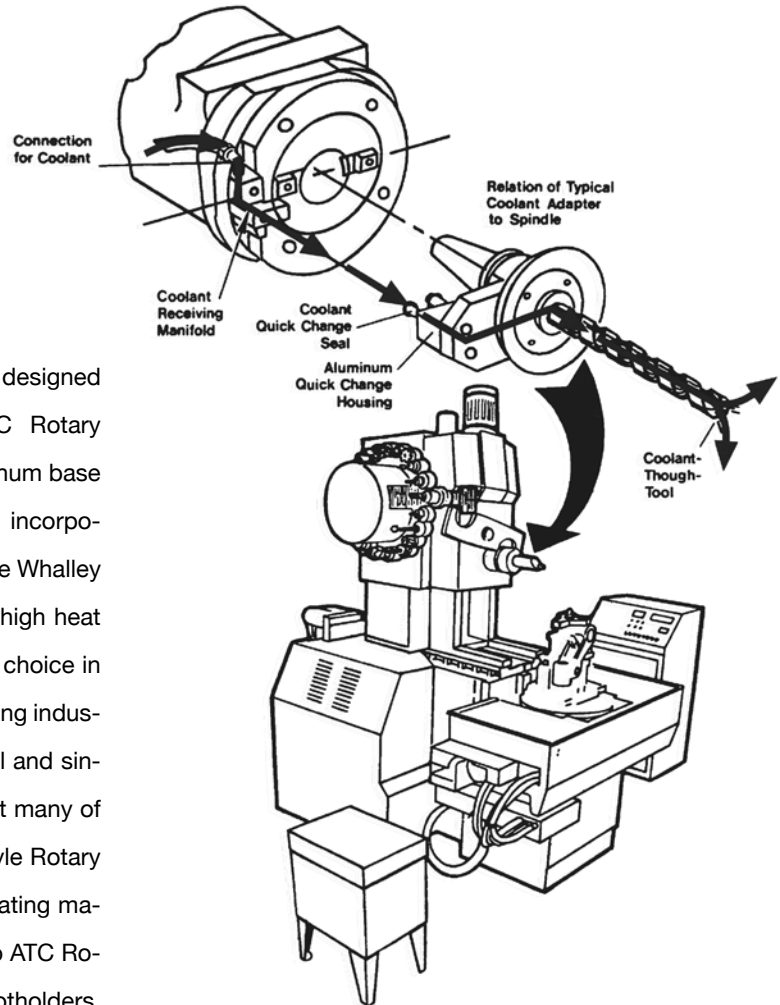

**AUTO TOOL
CHANGE : ATC**

REQUIREMENTS FOR RETROFITTING

- SUFFICIENT CLEARANCE IN TOOL CAROUSEL AND TOOL TRANSFER ARM AREAS.
- PROPER FILTERED AND PRESSURIZED COOLANT SUPPLY TO SERVE AUXILIARY MANIFOLD AT SPINDLE FACE.
- COOLANT FILTRATION AND PUMPING SYSTEM CAPABLE OF PRODUCING THE VOLUME AND PRESSURE NECESSARY FOR TYPES OF TOOLS BEING USED.
- PROPER MATCHING OF THE SPINDLE SPECIFICATIONS TO THE CORRECT HOLDER AND GLAND.
- CNC CONTROLS ABLE TO OPERATE COOLANT FLOW TO THE AUXILIARY MANIFOLD.
- APPROPRIATE SHIELDING OF THE MACHINE TO HANDLE COOLANT FLOW WITHOUT SPLASHING.



SINGLE PIN FACE SEAL (SPFS) • AUTOMATIC TOOL CHANGE (ATC) ROTARY COOLANT GLAND ASSEMBLY

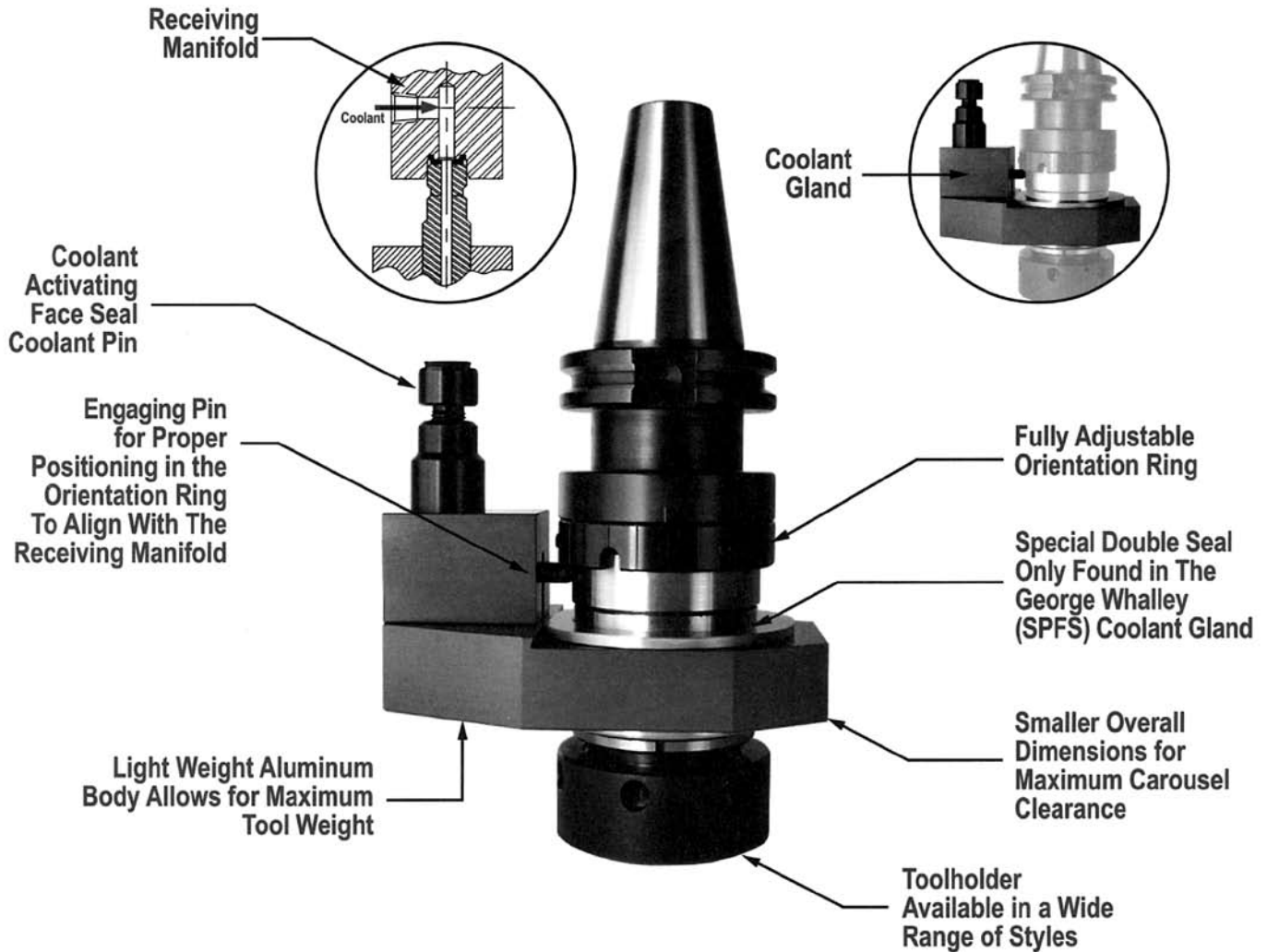

COOLANT GLAND SELECTION

The Single Pin Face Seal (SPFS) Rotary Coolant Gland is the newest and most popular of The George Whalley Company ATC Coolant Gland assemblies. It is interchangeable with most foreign and domestic automatic tool change systems.

The Single Pin Face Seal (SPFS) Coolant Gland is used when your CNC machine spindle accepts a toolholder with a Cat 40, 45, 50 V-Flange or BT40, BT50 shank.

TOOLHOLDER SELECTION

- To order V-Flange Holders with (SPFS) Rotary Coolant Glands see pages 90-93.
- To order BT Shank Holders with (SPFS) Rotary Coolant Glands see pages 93-94.

RECEIVING MANIFOLD SELECTION AND SET-UP INFORMATION

The (SPFS) Coolant Gland requires the installation of a (SPFS) Receiving Manifold to activate the system (see next page).

General Operating Recommendations For All Coolant Glands See Page 88



SINGLE PIN FACE (SPFS) RECEIVING MANIFOLD BLANK

(SPFS) RECEIVING MANIFOLD SET-UP DIMENSIONS

Single Pin Face Seal Style Manifold (Figure 1) showing how a Receiving Manifold is mounted to the spindle cover of the machine.

FIGURE 1

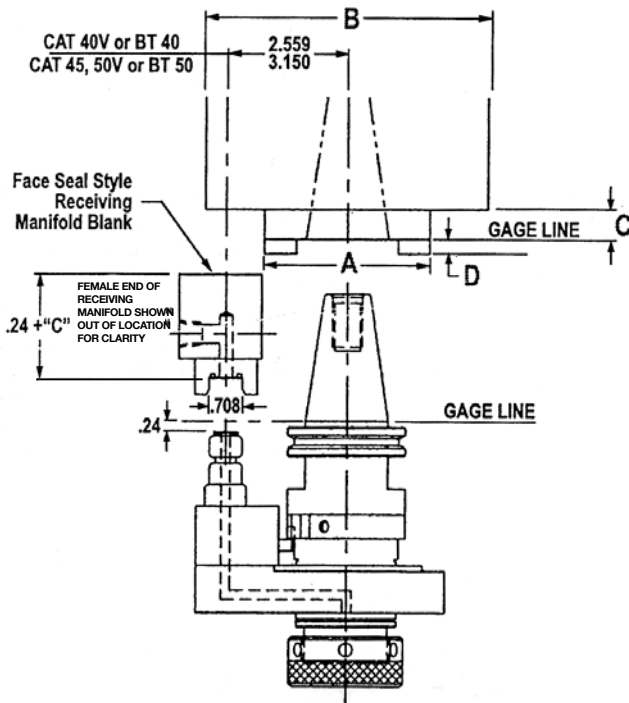
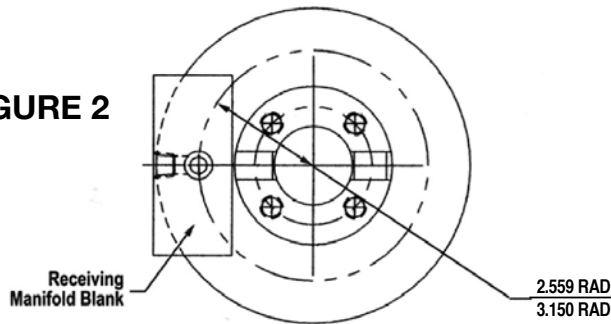

FIGURE 2



Spindle face (Figure 2) showing where the Receiving Manifold must be mounted. A radius of 2.559 must be maintained for CAT 40V or BT 40 shanks. A radius of 3.150 must be maintained for CAT 45, 50V or BT 50 shanks.

SINGLE PIN FACE SEAL RECEIVING MANIFOLD BLANK

Interchangeable with most foreign and domestic manufacturers CAT 40, 45, 50V or BT 40 and BT 50 shanks.

ORDERING OPTIONS (Figure 3)

1. Purchase (SPFS) Manifold Blank (Part No. 117-100) and you alter to suit your machine requirements.

2. Purchase (SPFS) Manifold Blank and have The George Whalley Company custom machine your Manifold Blank to suit your requirements by filling out the information listed below. Pricing and delivery will be quoted after receipt of this information.

Using Figure 1 and Figure 2, please supply the following information for modifications on the Receiving Manifold Block

Machine Spindle Taper (check one)

A _____

B _____

C _____

D _____

- CAT 40V
- BT 40
- CAT 45V
- CAT 50V
- BT 50

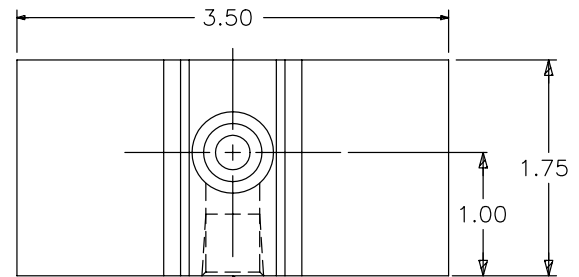
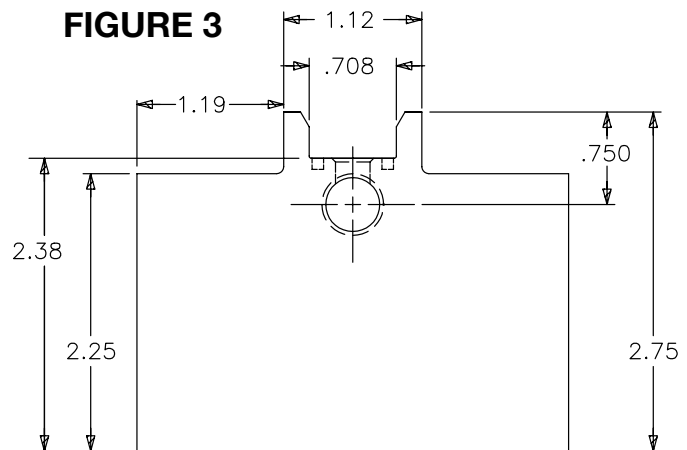

FIGURE 3



Shown are the basic dimensions of the Receiving Manifold Blank BEFORE modification.

PART NUMBER	DESCRIPTION
117-100	Single Pin Face Seal (SPFS) Receiving Manifold Blank

AUTO TOOL CHANGE - ATC



SINGLE PIN O-RING (SPOR) • AUTOMATIC TOOL CHANGE (ATC) ROTARY COOLANT GLAND ASSEMBLY

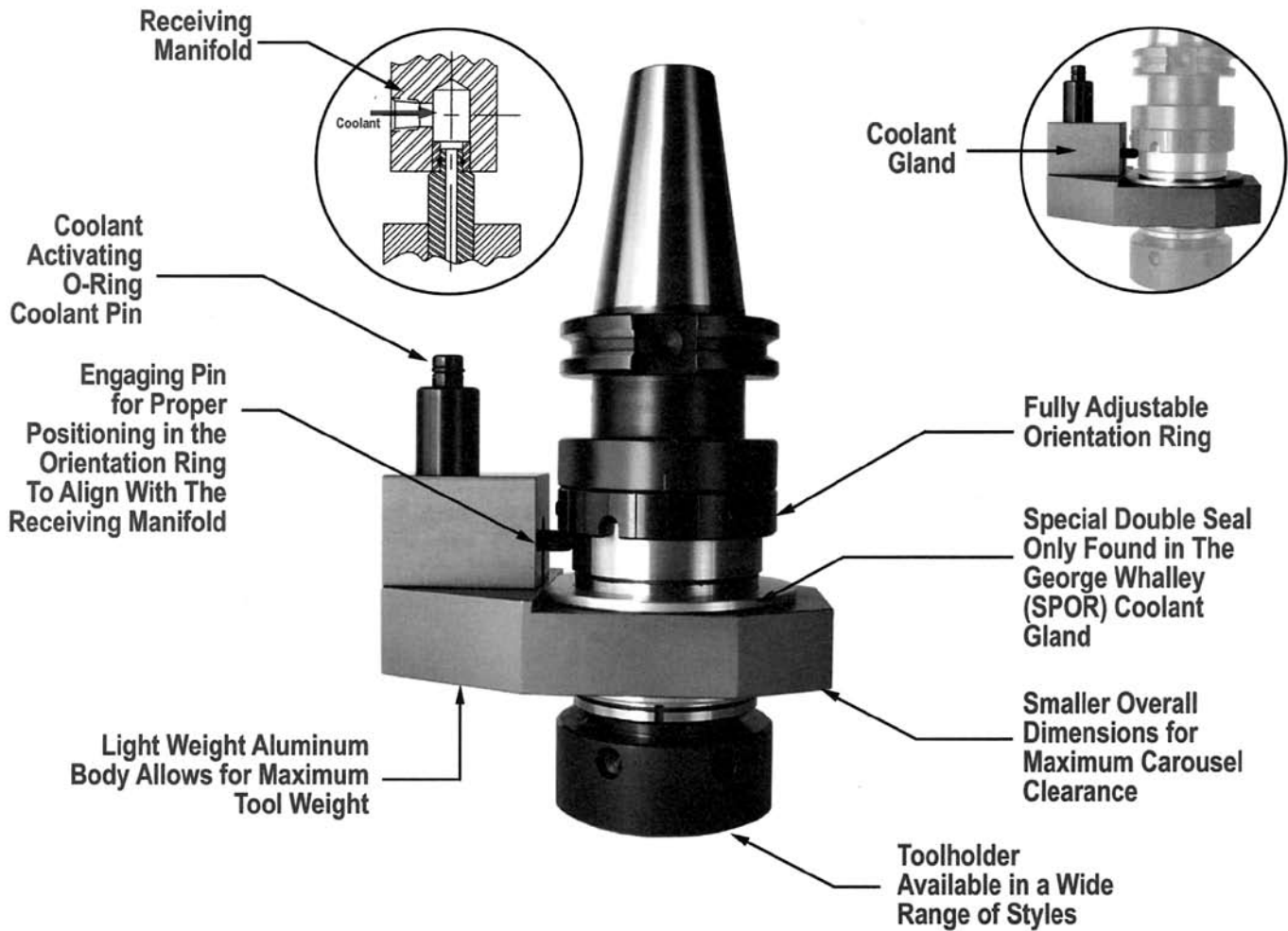

COOLANT GLAND SELECTION

The Single Pin O-Ring (SPOR) Rotary Coolant Gland of The George Whalley Company offers excellent radial location for the best engagement of the Coolant Pin into the Receiving Manifold.

The Single Pin O-Ring (SPOR) Coolant Gland is used when your CNC machine spindle accepts a toolholder with a Cat 40 V-Flange or BT40 shank.

TOOLHOLDER SELECTION

- To order V-Flange Holders with (SPOR) Rotary Coolant Glands see pages 95-97.
- To order BT Shank Holders with (SPOR) Rotary Coolant Glands see pages 97-98.

RECEIVING MANIFOLD

The (SPOR) Coolant Gland requires the installation of a (SPOR) Receiving Manifold to activate the system (see next page).

*General Operating
Recommendations
For All Coolant
Glands See
Page 88*



SINGLE PIN O-RING (SPOR) RECEIVING MANIFOLD BLANK

(SPOR) RECEIVING MANIFOLD SET-UP DIMENSIONS

Single Pin O-Ring Seal Style Manifold (**Figure 1**) showing how a Receiving Manifold is mounted to the spindle cover of the machine.

FIGURE 1

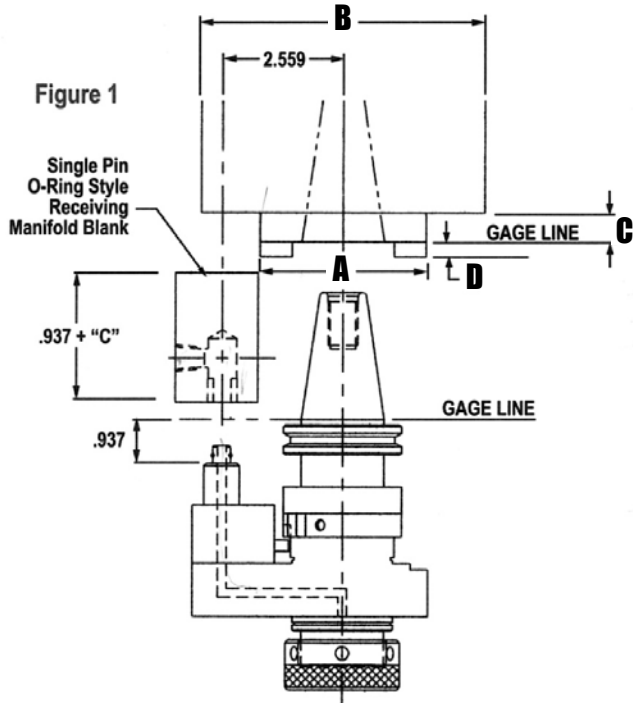
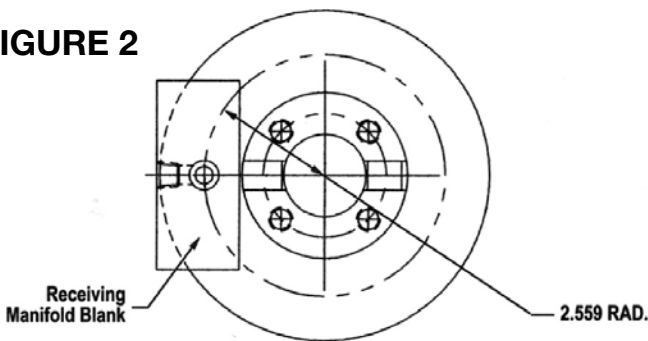

FIGURE 2



Spindle face (**Figure 2**) showing where the Receiving Manifold must be mounted. A radius of 2.559 must be maintained for CAT 40V or BT 40 shanks.

SINGLE PIN O-RING RECEIVING MANIFOLD BLANK

For CAT 40 V or BT 40 shanks

ORDERING OPTIONS (Figure 3)

1. Purchase (SPOR) Manifold Blank (Part No.117-200) and you alter to suit your machine requirements.
2. Purchase (SPOR) Manifold Blank and have The George Whalley Company custom machine your Manifold Blank to suit your requirements by filling out the information listed below. Pricing and delivery will be quoted after receipt of this information.

Using **Figure 1** and **Figure 2**, please supply the following information for modifications on the Receiving Manifold Block

Machine Spindle Taper
(check one)

A	_____
B	_____
C	_____
D	_____

CAT 40V
 BT 40

FIGURE 3

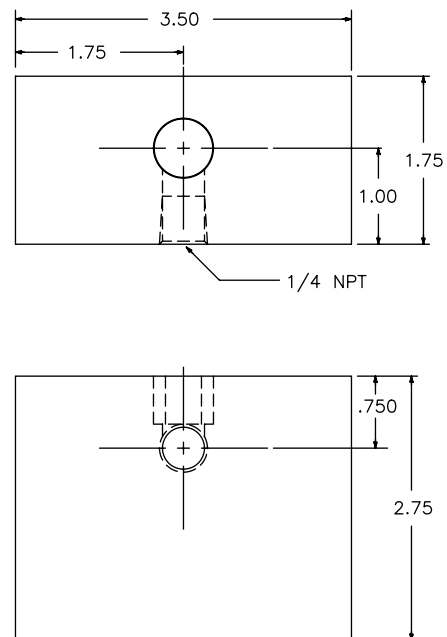

Shown are the basic dimensions of the Receiving Manifold Blank BEFORE modification.

PART NUMBER	DESCRIPTION
117-200	Single Pin O-Ring (SPOR) Receiving Manifold Blank

AUTO TOOL
CHANGE : ATC



DUAL PIN O-RING (DPOR) • AUTOMATIC TOOL CHANGE (ATC) ROTARY COOLANT GLAND ASSEMBLY

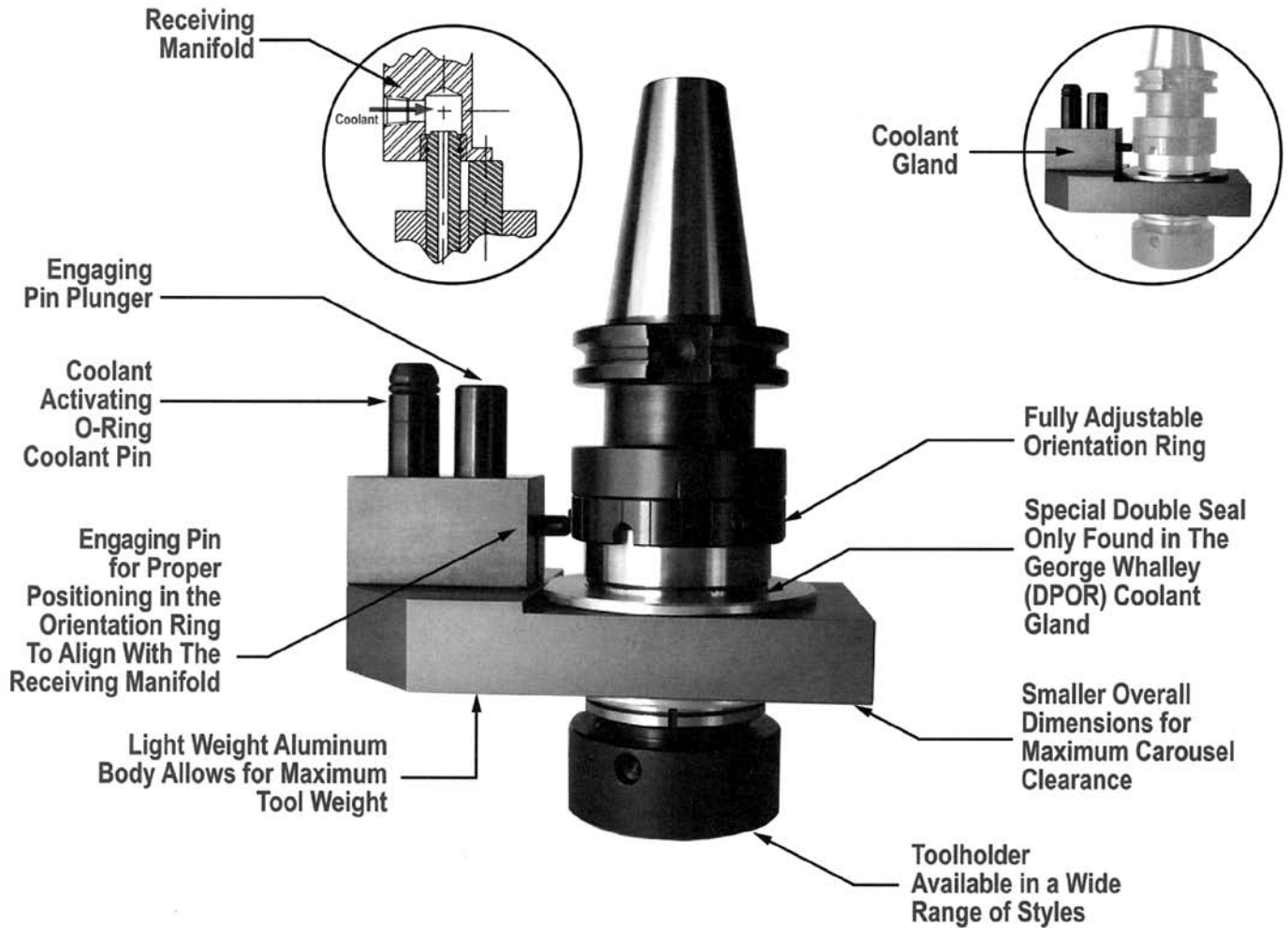

COOLANT GLAND SELECTION

The Dual Pin O-Ring (DPOR) Rotary Coolant Gland of The George Whalley Company offers minimum as well as maximum coolant pressure capabilities. It also provides the best radial location for the proper engagement of the Coolant Pin to the Receiving Manifold.

The Dual Pin O-Ring (DPOR) Coolant Gland is used when your CNC machine spindle accepts a toolholder with a Cat 45, 50 V-Flange, BT50 or K&T 200/300 Series. (K&T by special request)

TOOLHOLDER SELECTION

- To order V-Flange Holders with (DPOR) Rotary Coolant Glands see pages 99-101.
- To order BT Shank Holders with (DPOR) Rotary Coolant Glands see pages 103-104.
- To order K&T Holders with (DPOR) Rotary Coolant Glands see page 102.

RECEIVING MANIFOLD

The (DPOR) Coolant Gland requires the installation of a (DPOR) Receiving Manifold to activate the system (see next page).

*General
Operating
Recommendations
For All Coolant
Glands See
Page 88*



DUAL PIN O-RING (DPOR) RECEIVING MANIFOLD BLANK

(DPOR) RECEIVING MANIFOLD SET-UP DIMENSIONS

Dual Pin O-Ring Style Manifold (Figure 1) showing how a Receiving Manifold is mounted to the spindle cover of the machine.

FIGURE 1

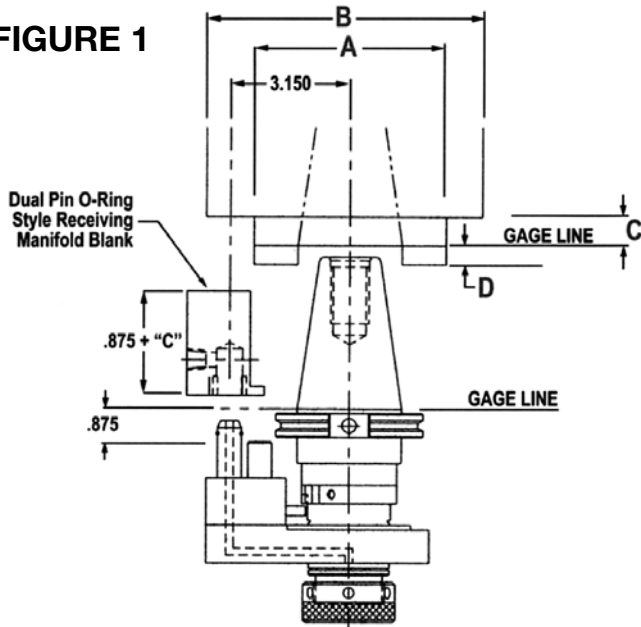
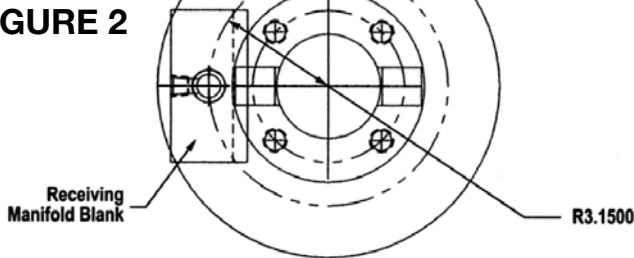

FIGURE 2



Spindle face (Figure 2) showing where the Receiving Manifold must be mounted. A radius of 3.150 must be maintained for CAT 45V, 50V or BT 50 shanks.

DUAL PIN O-RING RECEIVING MANIFOLD BLANK

For CAT 45, CAT 50V, or BT 50 shanks

ORDERING OPTIONS (Figure 3)

1. Purchase (DPOR) Manifold Blank (Part No.117-300) and you alter to suit your machine requirements.
2. Purchase (DPOR) Manifold Blank and have The George Whalley Company custom machine your Manifold Blank to suit your requirements by filling out the information listed below. Pricing and delivery will be quoted after receipt of this information.

Using Figure 1 and Figure 2, please supply the following information for modifications on the Receiving Manifold Block

Machine Spindle Taper
(check one)

A	_____
B	_____
C	_____
D	_____

<input type="checkbox"/>	CAT 45
<input type="checkbox"/>	CAT 50V
<input type="checkbox"/>	BT 50

AUTO TOOL
CHANGE : ATC

FIGURE 3

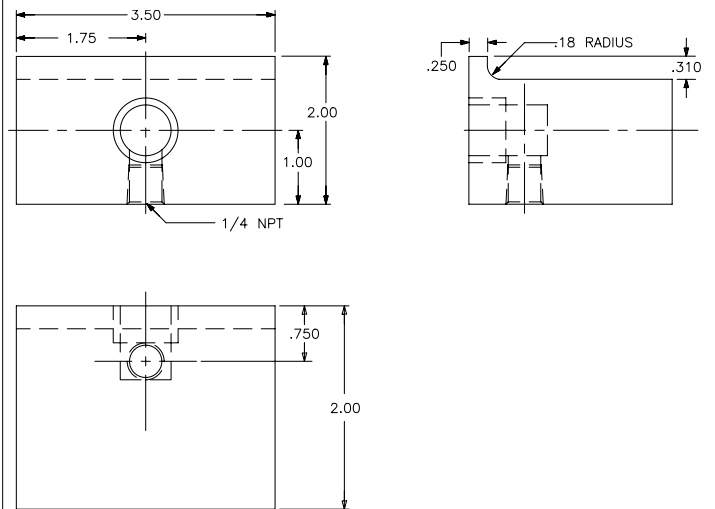

Shown are the basic dimensions of the Receiving Manifold Blank BEFORE modification.

PART NUMBER	DESCRIPTION
117-300	Dual Pin O-Ring (DPOR) Receiving Manifold Blank



MANUAL (MG), ROTARY COOLANT GLAND ASSEMBLY

- **Designed for preliminary manual applications.**
- **Upgrade to an Automatic Coolant Gland Assembly without purchasing another holder.**
- **For use on CNC machines with CAT 40, 45, 50V and BT 40, BT 50 shanks.**

Toolholders can be utilized with a Manual Rotary Coolant Gland if the automatic tool change function is not required.

The Manual Rotary Coolant Gland is an economical means for proving out coolant-thru-the-tool processing.

The Manual Rotary Gland can also be used on Manual Machines with auxiliary coolant.

TOOLHOLDER SELECTION

- To order V-Flange Holders with Manual (MG) Rotary Coolant Glands see pages 104-106.
- To order BT Shank Holders with Manual (MG) Rotary Coolant Glands see pages 107-108.

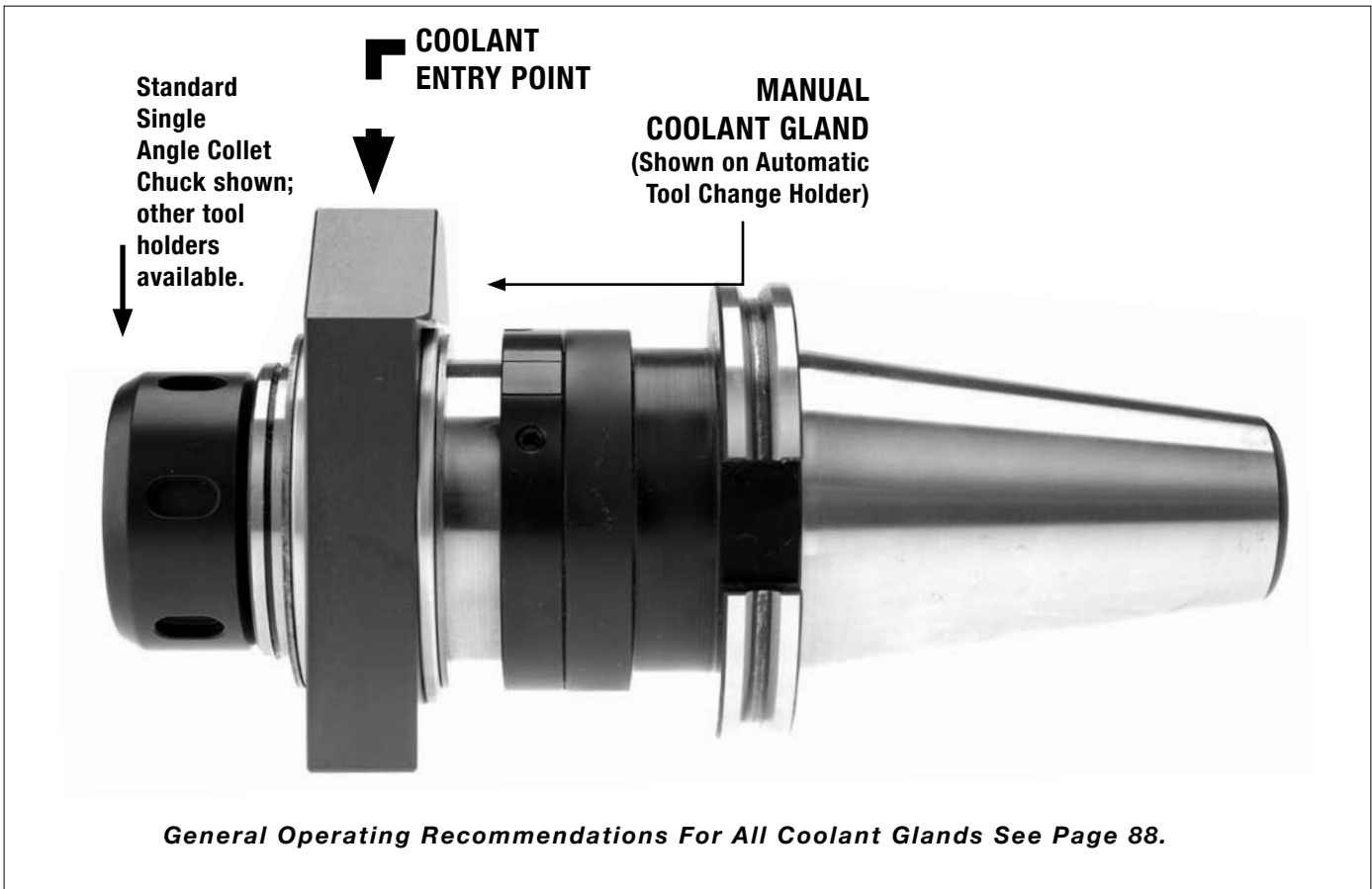



INSTALLING THE RECEIVING MANIFOLD & COOLANT SYSTEM FOR AUTOMATIC CHANGING OF COOLANT-FED TOOLS

It is necessary to have the receiving block, tool holder and coolant gland assembly before the start of installation. The make and design of your particular machine will indicate which three modes of receiving block installations will best serve your operation. The George Whalley Company attempts to maintain records on specifications for machine tools. We cannot be responsible for changes or improvements to your particular machine tool and therefore must ask that you carefully review all specifications which we may provide. Use the following suggested procedure and double check each step of the installation.

Note: These instructions are to be followed after modification of Receiving Manifold Blank have been made to suit your machine.

1. Orient the spindle to the tool change position.
2. Load the automatic tool holder and gland assembly to the spindle. Observe the area where the receiving manifold is to be located. If there are any bolts, pins, or fasteners in this area, remove them at this time. Temporarily mark the location where the Receiving Manifold is to be mounted.
3. Remove the automatic tool holder assembly and receiving manifold from the machine. Thoroughly clean the manifold locating surface and the marked area to contain the manifold. Use lacquer thinner or solvent to clean oil or dirt from the mating surfaces.
4. Apply a generous coating of any brand of super type glue to the receiving manifold and mating surface to contain the manifold. Re-check spindle orient location at this time. Load the gland assembly to the machine along with the receiving manifold. The spring pressure of the gland assembly will hold the receiving manifold in place. Allow a proper time for the glue to set and adhere.
5. Remove the gland assembly from the spindle.
6. Use the existing mounting holes in the receiving manifold as a template to locate the matching holes on the machine member. Drill and tap holes as required. Drill dowel pin holes.
7. Re-assemble the coolant gland to the machine. Do not securely tighten the mounting bolts.
8. Re-load the gland assembly to the spindle allowing the receiving manifold and mating machine member to each find its ideal location. Secure all bolts. Ream the dowel pin holes and install the dowel pins.
See pages 80-85 for Receiving Manifold mounting information and dimensions.

AUTO TOOL CHANGE : ATC

TWO PIECE CONSTRUCTION TOOLHOLDERS AS SEEN ON PAGES 92, 93, AND 101.

The Two Piece Construction Holder with matching coolant gland assembly (shown on pages 92, 93, and 101) is designed to adapt large shank tooling to The George Whalley Company automatic tool change system. The system consists of the following three units:

1. **Shank Assembly** -The shank assembly has a #50 Cat. V-Flange taper with a #40 internal taper and two drive keys.
2. **Head Assembly** -The head assembly has a #40 taper shank and two drive slots. Straight bore or collet style front ends are available.
3. **Coolant Gland** - The coolant gland is located on the head assembly and automatically connects and disconnects from the receiving manifold which is mounted in proximity to the machine spindle.

The head and shank assemblies are located by drive and slot keys. The head and shank are fastened together by a draw screw. Concentricity is the same as one piece holders, approximately 0.0005" at the toolholder face.



BRIEF CHECK LIST FOR START-UP

The following is a useful outline of procedures for installation of coolant-fed automatic tool change equipment in your machine:

1. Check to see that you have a receiving manifold properly installed on your machine and connected to its coolant system.
2. If you have a face seal adjustable coolant pin make sure it is adjusted for appropriate length to release the Activating Pin. Be sure that the set screw on top pin is locked.
3. Adjust orientation ring on toolholder to suit manifold location.
4. Tighten orientation ring screws in position, place coolant holder and gland in tool carousel and run slowly through tool change cycle, making sure of clearance at all points.
5. Follow Break In and Operating Recommendations (listed below).
6. After completion of break in procedure, you may bring the tool holder up to speed.

CAUTION! Should gland show signs of overheating, stop operations and consult detailed operating instructions.

BREAK IN AND OPERATING RECOMMENDATIONS FOR AUTOMATIC AND MANUAL TOOL CHANGE COOLANT GLANDS

In order to assure proper lubrication, even wear, and proper seating, high RPM glands should be broken in at 100 RPM for 3 minutes with coolant introduced at a pressure and volume between 100 PSI and 500 PSI to prevent overloading seals. Repeat procedure at 500 RPM for 3 minutes, and again at 1000 RPM. After break in procedure is complete, units may be run at pressure between 100 PSI and 1000 PSI.

For maximum life and performance of these coolant glands and seals the following conditions are recommended:

1. Coolant filtration: 30 to 50 micron minimum; 5 micron optimum
2. Proper type & viscosity of coolant: preferably a good water soluble synthetic with good lubrication and heat dissipation under pressure.
3. Coolant pressure: minimum of 100 lbs. coolant pressure at high R.P.M.'s (1800 SFM or more based on I.D. dimension of coolant gland or O.D. bearing diameter of tool holder). Maximum pressure of 1000 PSI
4. Coolant volume must be sufficient to properly lubricate cutting tool as recommended by its manufacturer. The combination of volume and pressure can not exceed the coolant orifice delivery capability of your tool or premature gland failure may result due to excessive heat build up.

CAUTION! All coolant glands require coolant at all speeds.

CAUTION! Operating RPM up to 1800 SFM based on the I.D. size of coolant gland or O.D. bearing diameter of toolholder.



SPECIAL APPLICATION ROTARY COOLANT GLAND ASSEMBLIES



FIGURE 1



FIGURE 2

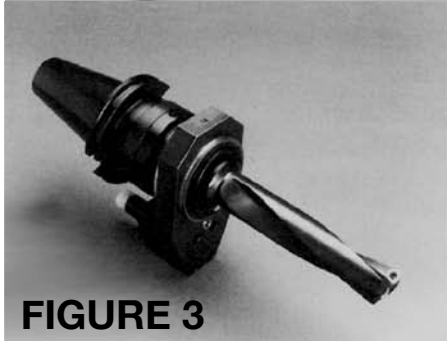

FIGURE 3

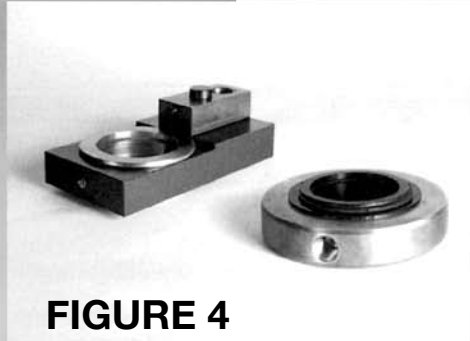

FIGURE 4

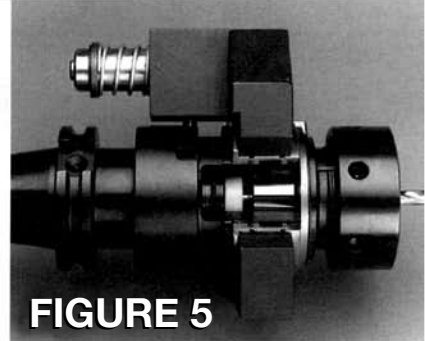

FIGURE 5

AUTO TOOL
CHANGE : ATC

SEE PAGE 110 FOR SPECIAL APPLICATION ROTARY COOLANT GLAND ASSEMBLY QUESTIONNAIRE.

FIGURE 1 -HSK Shank tooling with high speed coolant gland

FIGURE 2 -Various Style Coolant Gland Assemblies, Manifolds and Convertible Adapter Coolant Pin
-Can be supplied for 40, 45, 50, and 60 taper V-Flange or BT Style Shanks

FIGURE 3 -Coolant Gland With High Pressure Sealing Device

FIGURE 4 -Low Profile Coolant Gland Assembly and Special 2 Piece Flexible Rotary Gland

FIGURE 5 -Special Coolant Gland With Unique Internal Sealing Adaptation

The George Whalley Company will design and develop Automatic Coolant Systems to meet your requirements. The following is a partial list of some of the more popular machines our engineering staff has designed systems for:

- Bohle
- Cincinnati -Milacron
- Giddings & Lewis
- Hitachi -Seiki
- Kearney & Trecker
- LeBlonde -Makino
- Mazak
- Mitsubishi
- Mori Seiki
- Niigata
- Osaka Kiko (OKK)
- Toshiba
- Toyoda
- Hillyer
- Maho



Visit our website at www.coolantfedtooling.com for technical information and our latest product offerings.



V-FLANGE SINGLE ANGLE COLLET CHUCK • SINGLE PIN FACE SEAL ROTARY COOLANT GLAND

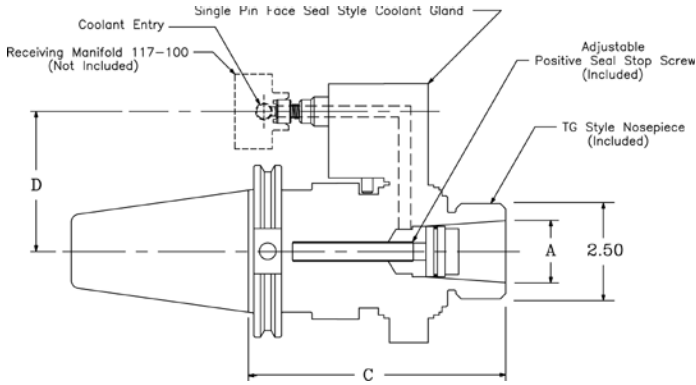

TG STYLE COLLETS
See Page 146.

• See page 111 for positive seal stop screw.

ASSEMBLY PART NUMBER	A RANGE (IN.)	COLLET SERIES	CLEARANCE DIAMETER (IN.)	C PROJ. (IN.)	D CTR TO CTR (IN.)	COOLANT GLAND (INCLUDED)	MINIMUM COOLANT PRESSURE (1)	MAXIMUM COOLANT PRESSURE (2)	MAXIMUM SPEED (RPM) (3)	OPTIONAL EXTENSION STYLE STOP SCREW (NOT INCLUDED)	REPLACEMENT SEAL KIT PART NUMBER (NOT INCLUDED)	SPANNER WRENCH (NOT INCLUDED)
40 V-FLANGE												
C40-TG10-SPFS-6	0.094 - 1.000	TG 100	2.50	6.00	2.559	AI-9889N	100 PSI	1000 PSI	3000	116-004	585-916	112-001
45 V-FLANGE												
*C45-TG10-SPFS-6	0.094 - 1.000	TG 100	2.50	6.00	3.150	AI-9989S	100 PSI	1000 PSI	2500	116-001	585-920	112-001
50 V-FLANGE												
C50-TG10-SPFS-6	0.094 - 1.000	TG 100	2.50	6.00	3.150	AI-9989S	100 PSI	1000 PSI	2500	116-001	585-920	112-001

* Outgoing Items

(1), (2) - These are recommended pressures. Lower coolant pressures may be utilized at very slow RPM's. Pressures above recommended PSI may cause internal damage to seals.
(3) - Recommended Maximum RPM at Maximum 1000 PSI. Higher speeds may be achieved at lower pressures.

These RPM and Pressure ranges are not a guarantee of performance. The life and performance of the units depends on the following conditions:

Proper Filtration - Proper Type & Viscosity of Coolant - Coolant Pressure and Volume.

All units require coolant at all speeds.

V-FLANGE END MILL HOLDERS • SINGLE PIN FACE SEAL ROTARY COOLANT GLAND

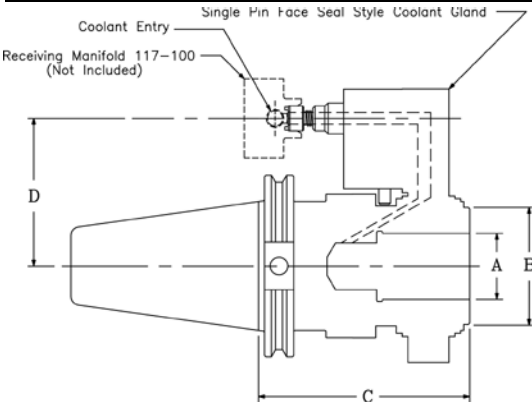

ASSEMBLY PART NUMBER	A I.D. (IN.)	B CLEARANCE DIA. (IN.)	C PROJECTION (IN.)	D CTR TO CTR (IN.)	COOLANT GLAND (INCLUDED)	MINIMUM COOLANT PRESSURE (1)	MAXIMUM COOLANT PRESSURE (2)	MAXIMUM SPEED (RPM) (3)	COOLANT STOP SCREW (INCLUDED)	REPLACEMENT SEAL KIT PART NUMBER (NOT INCLUDED)
40 V-FLANGE										
C40-EM75-SPFS-6	0.750	1.312	5.50	2.559	AI-9789V	100 PSI	1000 PSI	4000	NONE	585-904
C40-EM10-SPFS-6	1.000	1.625	5.50	2.559	AI-9789T	100 PSI	1000 PSI	3300	NONE	585-912
^C40-EM12-SPFS-5	1.250	2.125	4.50	2.559	AI-9889N	100 PSI	1000 PSI	3000	105-005	585-916
45 V-FLANGE										
*C45-EM75-SPFS-5	0.750	1.312	4.50	3.150	AI-0189Y	100 PSI	1000 PSI	4000	NONE	585-904
*C45-EM10-SPFS-5	1.000	1.625	4.50	3.150	AI-0189T	100 PSI	1000 PSI	3300	NONE	585-912
^*C45-EM12-SPFS-5	1.250	2.500	4.50	3.150	AI-9989S	100 PSI	1000 PSI	2500	105-003	585-920
^^C45-EM15-SPFS-5	1.500	2.500	4.50	3.150	AI-9989S	100 PSI	1000 PSI	2500	105-003	585-920
50 V-FLANGE										
C50-EM75-SPFS-6	0.750	1.312	5.50	3.150	AI-0189Y	100 PSI	1000 PSI	4000	NONE	585-904
C50-EM10-SPFS-6	1.000	1.625	5.50	3.150	AI-0189T	100 PSI	1000 PSI	3300	NONE	585-912
^C50-EM12-SPFS-5	1.250	2.500	4.50	3.150	AI-9989S	100 PSI	1000 PSI	2500	105-004	585-920
^C50-EM15-SPFS-5	1.500	2.500	4.50	3.150	AI-9989S	100 PSI	1000 PSI	2500	105-004	585-920
^C50-EM20-SPFS-7	2.000	3.187	6.50	3.150	AR-0689Z	100 PSI	1000 PSI	1800	105-010	585-922

* Outgoing Items ^ - Socket set screw location does not conform to ANSI specification. Request information if set screw location is critical

(1), (2) - These are recommended pressures. Lower coolant pressures may be utilized at very slow RPM's. Pressures above recommended PSI may cause internal damage to seals.

(3) - Recommended Maximum RPM at Maximum 1000 PSI. Higher speeds may be achieved at lower pressures.

These RPM and Pressure ranges are not a guarantee of performance. The life and performance of the units depends on the following conditions:

Proper Filtration - Proper Type & Viscosity of Coolant - Coolant Pressure and Volume.

All units require coolant at all speeds.



V-FLANGE DOUBLE ANGLE COLLET CHUCK - SINGLE PIN FACE SEAL ROTARY COOLANT GLAND

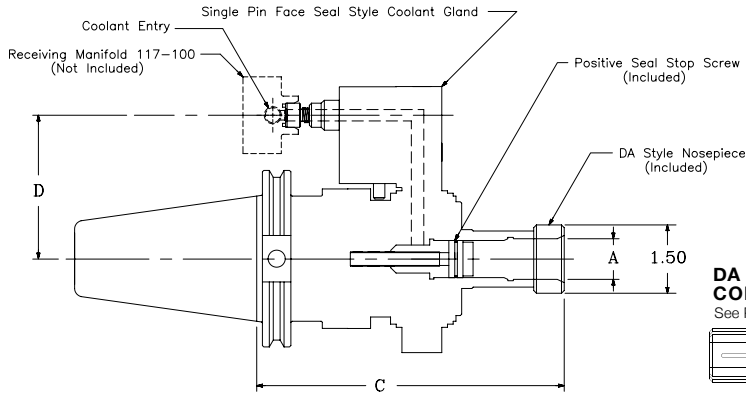

•See page 111 for positive seal stop screw.

ASSEMBLY PART NUMBER	A RANGE (IN.)	COLLET SERIES	CLEARANCE DIAMETER (IN.)	C PROJECTION (IN.)	D CTR TO CTR (IN.)	COOLANT GLAND (INCLUDED)	MINIMUM COOLANT PRESSURE (1)	MAXIMUM COOLANT PRESSURE (2)	MAXIMUM SPEED (RPM) (3)	REPLACEMENT SEAL KIT PART NUMBER (NOT INCLUDED)	SPANNER WRENCH (NOT INCLUDED)
40 V-FLANGE											
*C40-DA18-SPFS-7	0.047 - 0.750	DA 180	1.50	7.00	2.559	AI-9789V	100 PSI	1000 PSI	4000	585-904	112-019

* Outgoing Items

(1), (2) - These are recommended pressures. Lower coolant pressures may be utilized at very slow RPM's. Pressures above recommended PSI may cause internal damage to seals.
 (3) - Recommended Maximum RPM at Maximum 1000 PSI. Higher speeds may be achieved at lower pressures.

These RPM and Pressure ranges are not a guarantee of performance. The life and performance of the units depends on the following conditions:
 Proper Filtration - Proper Type & Viscosity of Coolant - Coolant Pressure and Volume.
All units require coolant at all speeds.

V-FLANGE MORSE TAPER HOLDERS - SINGLE PIN FACE SEAL ROTARY COOLANT GLAND

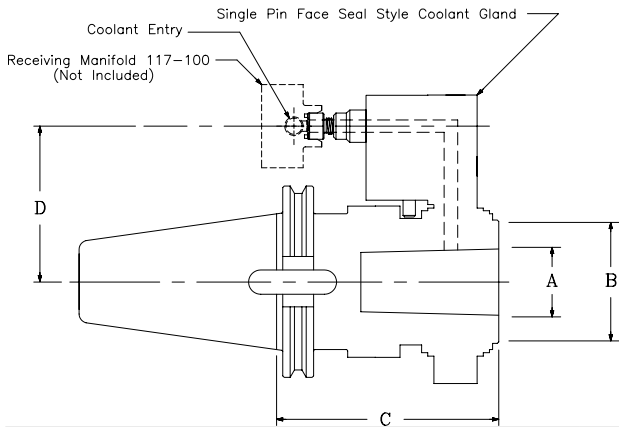

Retention Knobs Sold Separately, See Pages 163-167.



AUTO TOOL CHANGE - ATC

ASSEMBLY PART NUMBER	A MORSE TAPER	B CLEARANCE DIA. (IN.)	C PROJECTION (IN.)	D CTR TO CTR (IN.)	COOLANT GLAND (INCLUDED)	MINIMUM COOLANT PRESSURE (1)	MAXIMUM COOLANT PRESSURE (2)	MAXIMUM SPEED (RPM) (3)	REPLACEMENT SEAL KIT PART NUMBER (NOT INCLUDED)
40 V-FLANGE									
C40-MT3-SPFS-5	MT3	2.125	4.50	2.559	AI-9889N	100 PSI	1000 PSI	3000	585-916
C40-MT3-SPFS-5A	MT3	1.312	4.50	2.559	AI-9789V	100 PSI	1000 PSI	4000	585-904
C40-MT4-SPFS-5	MT4	2.125	4.50	2.559	AI-9889N	100 PSI	1000 PSI	3000	585-916
C40-MT4-SPFS-5A	MT4	1.312	4.50	2.559	AI-9789V	100 PSI	1000 PSI	4000	585-904
45 V-FLANGE									
*C45-MT3-SPFS-5	MT3	2.500	4.50	3.150	AI-9989S	100 PSI	1000 PSI	2500	585-920
*C45-MT3-SPFS-5A	MT3	1.312	4.50	3.150	AI-0189Y	100 PSI	1000 PSI	4000	585-904
*C45-MT4-SPFS-5	MT4	2.500	4.50	3.150	AI-9889S	100 PSI	1000 PSI	2500	585-920
*C45-MT4-SPFS-5A	MT4	1.312	4.50	3.150	AI-0189Y	100 PSI	1000 PSI	4000	585-904
50 V-FLANGE									
C50-MT3-SPFS-5	MT3	2.500	4.50	3.150	AI-9989S	100 PSI	1000 PSI	2500	585-920
C50-MT3-SPFS-5A	MT3	1.312	4.50	3.150	AI-0189Y	100 PSI	1000 PSI	4000	585-904
C50-MT4-SPFS-5	MT4	2.500	4.50	3.150	AI-9989S	100 PSI	1000 PSI	2500	585-920
C50-MT4-SPFS-5A	MT4	1.312	4.50	3.150	AI-0189Y	100 PSI	1000 PSI	4000	585-904
C50-MT5-SPFS-5	MT5	2.500	4.50	3.150	AI-9989S	100 PSI	1000 PSI	2500	585-920

* Outgoing Items

(1), (2) - These are recommended pressures. Lower coolant pressures may be utilized at very slow RPM's. Pressures above recommended PSI may cause internal damage to seals.
 (3) - Recommended Maximum RPM at Maximum 1000 PSI. Higher speeds may be achieved at lower pressures.

These RPM and Pressure ranges are not a guarantee of performance. The life and performance of the units depends on the following conditions:
 Proper Filtration - Proper Type & Viscosity of Coolant - Coolant Pressure and Volume.
All units require coolant at all speeds.



V-FLANGE ABS® STYLE HOLDERS • SINGLE PIN FACE SEAL ROTARY COOLANT GLAND

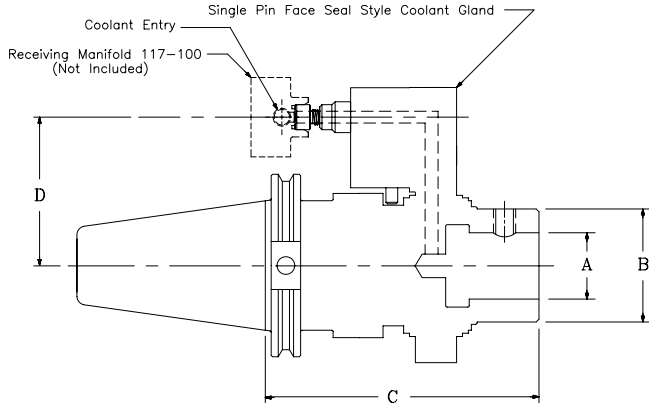

ASSEMBLY PART NUMBER	A ABS® CONNECTION	B CLEARANCE DIA. (IN.)	C PROJECTION (IN.)	D CTR TO CTR (IN.)	COOLANT GLAND (INCLUDED)	MINIMUM COOLANT PRESSURE (1)	MAXIMUM COOLANT PRESSURE (2)	MAXIMUM SPEED (RPM) (3)	REPLACEMENT SEAL KIT PART NUMBER (NOT INCLUDED)
40 V-FLANGE									
C40-ABS40-SPFS-6	ABS 40	1.625	5.25	2.559	AI-9789T	100 PSI	1000 PSI	3300	585-912
C40-ABS50-SPFS-6	ABS 50	2.125	5.50	2.559	AI-9889N	100 PSI	1000 PSI	3000	585-916
45 V-FLANGE									
*C45-ABS40-SPFS-6	ABS 40	1.625	5.25	3.150	AI-0189T	100 PSI	1000 PSI	3300	585-912
*C45-ABS50-SPFS-6	ABS 50	2.125	5.50	3.150	AI-9989X	100 PSI	1000 PSI	3000	585-916
*C45-ABS63-SPFS-6	ABS 63	2.500	5.62	3.150	AI-9989S	100 PSI	1000 PSI	2500	585-920
50 V-FLANGE ^									
C50-ABS40-SPFS-6	ABS 40	1.625	5.25	3.150	AI-0189T	100 PSI	1000 PSI	3300	585-912
C50-ABS50-SPFS-6	ABS 50	2.125	5.50	3.150	AI-9989X	100 PSI	1000 PSI	3000	585-916
C50-ABS63-SPFS-5	ABS 63	2.500	5.75	3.150	AI-9989S	100 PSI	1000 PSI	2500	585-920

* **Outgoing Items** ^ - ABS 80 & 100 holders available by special quotation on 50 V-Flange units.

ABS® is registered trademark of KOMET.

• Please refer to the Modular Tooling Section on pages 140-143 for Modular Adapters

(1), (2) - These are recommended pressures. Lower coolant pressures may be utilized at very slow RPM's. Pressures above recommended PSI may cause internal damage to seals.
(3) - Recommended Maximum RPM at Maximum 1000 PSI. Higher speeds may be achieved at lower pressures.

These RPM and Pressure ranges are not a guarantee of performance. The life and performance of the units depends on the following conditions:
Proper Filtration - Proper Type & Viscosity of Coolant - Coolant Pressure and Volume.
All units require coolant at all speeds.

V-FLANGE 2 PIECE SINGLE ANGLE COLLET CHUCK • SINGLE PIN FACE SEAL ROTARY COOLANT GLAND

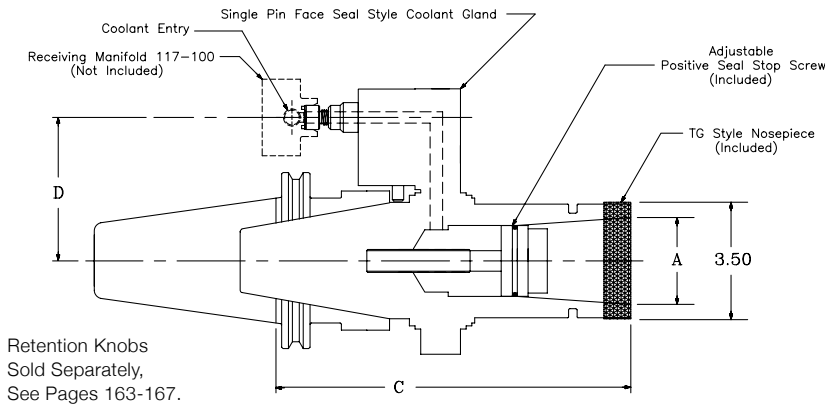

Retention Knobs
Sold Separately,
See Pages 163-167.



TG STYLE COLLETS
See Page 146.



• See page 111 for positive seal stop screw.

ASSEMBLY PART NUMBER	A RANGE (IN.)	COLLET SERIES	CLEARANCE DIA. (IN.)	C PROJ. (IN.)	D CTR TO CTR (IN.)	COOLANT GLAND (INCLUDED)	MINIMUM COOLANT PRESSURE (1)	MAXIMUM COOLANT PRESSURE (2)	MAXIMUM SPEED (RPM) (3)	REPLACEMENT SEAL KIT PART NUMBER (NOT INCLUDED)	SPANNER WRENCH (NOT INCLUDED)
50 V-FLANGE											
C50-TG15-2P-SPFS-9	0.500 - 1.500	TG 150	3.50	8.38	3.150	AI-9989S	100 PSI	1000 PSI	2500	585-920	112-002

• Especially designed to suit large shanked tools in a CNC carousel with limited space. • Utilizes standard coolant gland assemblies.

(1), (2) - These are recommended pressures. Lower coolant pressures may be utilized at very slow RPM's. Pressures above recommended PSI may cause internal damage to seals.
(3) - Recommended Maximum RPM at Maximum 1000 PSI. Higher speeds may be achieved at lower pressures.

These RPM and Pressure ranges are not a guarantee of performance. The life and performance of the units depends on the following conditions:
Proper Filtration - Proper Type & Viscosity of Coolant - Coolant Pressure and Volume.
All units require coolant at all speeds.



V-FLANGE 2 PIECE END MILL HOLDERS • SINGLE PIN FACE SEAL ROTARY COOLANT GLAND

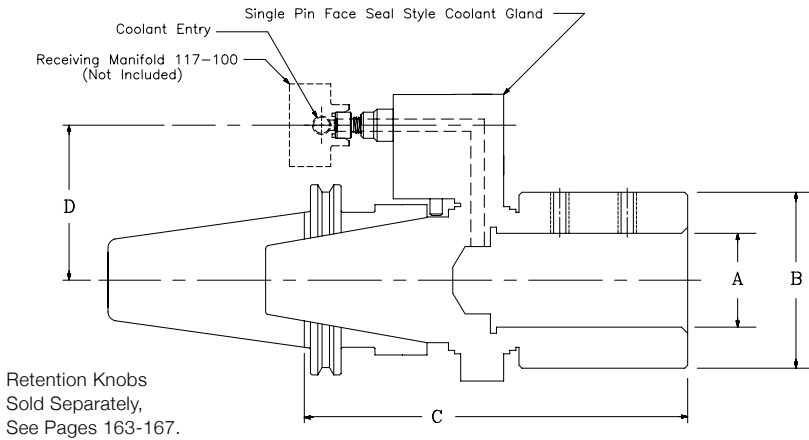

ASSEMBLY PART NUMBER	A I.D. (IN.)	B CLEARANCE DIA. (IN.)	C PROJECTION (IN.)	D CTR TO CTR (IN.)	COOLANT GLAND (INCLUDED)	MINIMUM COOLANT PRESSURE (1)	MAXIMUM COOLANT PRESSURE (2)	MAXIMUM SPEED (RPM) (3)	REPLACEMENT SEAL KIT PART NUMBER (NOT INCLUDED)
50 V-FLANGE									
C50-EM17-2P-SPFS-9	1.750	3.750	8.25	3.150	AI-9989S	100 PSI	1000 PSI	2500	585-920
C50-EM20-2P-SPFS-9	2.000	3.750	8.25	3.150	AI-9989S	100 PSI	1000 PSI	2500	585-920
C50-EM22-2P-SPFS-9	2.250	4.000	8.25	3.150	AI-9989S	100 PSI	1000 PSI	2500	585-920
C50-EM25-2P-SPFS-9	2.500	4.000	8.25	3.150	AI-9989S	100 PSI	1000 PSI	2500	585-920

• Especially designed to suit large shanked tools in a CNC carousel with limited space. • Utilizes standard coolant gland assemblies.

(1), (2) - These are recommended pressures. Lower coolant pressures may be utilized at very slow RPM's. Pressures above recommended PSI may cause internal damage to seals.
(3) - Recommended Maximum RPM at Maximum 1000 PSI. Higher speeds may be achieved at lower pressures.

These RPM and Pressure ranges are not a guarantee of performance. The life and performance of the units depends on the following conditions:

Proper Filtration - Proper Type & Viscosity of Coolant - Coolant Pressure and Volume.

All units require coolant at all speeds.

AUTO TOOL CHANGE - ATC

BT SINGLE ANGLE COLLET CHUCK • SINGLE PIN FACE SEAL ROTARY COOLANT GLAND

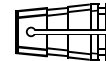
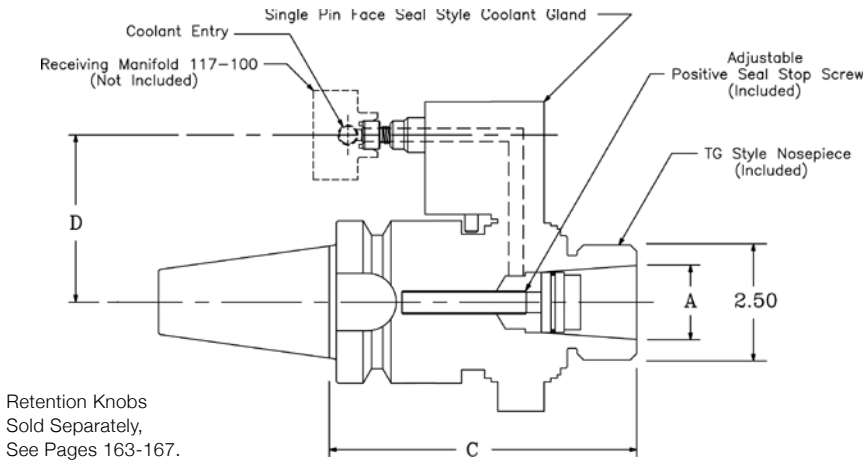

TG STYLE COLLETS
See Page 146.

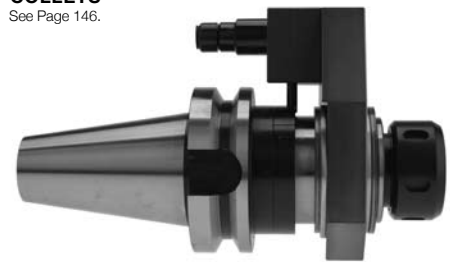

• See page 111 for positive seal stop screw.

ASSEMBLY PART NUMBER	A RANGE (IN.)	COLLET SERIES	CLEARANCE DIA. (IN.)	C PROJ. (IN.)	D CTR TO CTR (IN.)	COOLANT GLAND (INCLUDED)	MINIMUM COOLANT PRESSURE (1)	MAXIMUM COOLANT PRESSURE (2)	MAXIMUM SPEED (RPM) (3)	OPTIONAL EXTENSION STYLE STOP SCREW (NOT INCLUDED)	REPLACEMENT SEAL KIT PART NUMBER (NOT INCLUDED)	SPANNER WRENCH (NOT INCLUDED)
BT 40												
BT40-TG10-SPFS-6	0.094 - 1.000	TG 100	2.50	5.25	2.559	AI-9889N	100 PSI	1000 PSI	3000	116-004	585-916	112-001
BT 50												
BT50-TG10-SPFS-6	0.094 - 1.000	TG 100	2.50	5.25	3.150	AI-9989S	100 PSI	1000 PSI	2500	116-001	585-920	112-001

(1), (2) - These are recommended pressures. Lower coolant pressures may be utilized at very slow RPM's. Pressures above recommended PSI may cause internal damage to seals.

(3) - Recommended Maximum RPM at Maximum 1000 PSI. Higher speeds may be achieved at lower pressures.

These RPM and Pressure ranges are not a guarantee of performance. The life and performance of the units depends on the following conditions:

Proper Filtration - Proper Type & Viscosity of Coolant - Coolant Pressure and Volume.

All units require coolant at all speeds.



BT END MILL HOLDERS • SINGLE PIN FACE SEAL ROTARY COOLANT GLAND

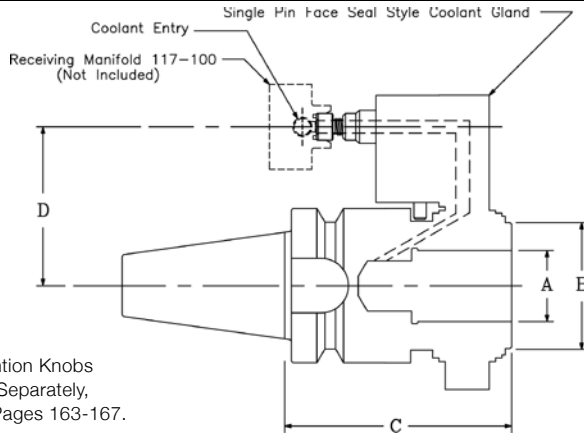

Retention Knobs
Sold Separately,
See Pages 163-167.

ASSEMBLY PART NUMBER	A I.D. (IN.)	CLEARANCE DIA. (IN.)	C PROJECTION (IN.)	D CTR TO CTR (IN.)	COOLANT GLAND (INCLUDED)	MINIMUM COOLANT PRESSURE (1)	MAXIMUM COOLANT PRESSURE (2)	MAXIMUM SPEED (RPM) (3)	COOLANT STOP SCREW (INCLUDED)	REPLACEMENT SEAL KIT PART NUMBER (NOT INCLUDED)
BT 40										
BT40-EM75-SPFS-6	0.750	1.312	5.50	2.559	AI-9789V	100 PSI	1000 PSI	4000	105-007	585-904
BT40-EM10-SPFS-5	1.000	2.125	4.50	2.559	AI-9889N	100 PSI	1000 PSI	3000	105-007	585-916
^BT40-EM12-SPFS-5	1.250	2.125	4.50	2.559	AI-9889N	100 PSI	1000 PSI	3000	105-007	585-916
BT 50										
BT50-EM10-SPFS-5	1.000	2.500	4.50	3.150	AI-9989S	100 PSI	1000 PSI	2500	105-006	585-920
^BT50-EM12-SPFS-5	1.250	2.500	4.50	3.150	AI-9989S	100 PSI	1000 PSI	2500	105-006	585-920
^BT50-EM15-SPFS-5	1.500	2.500	4.50	3.150	AI-9989S	100 PSI	1000 PSI	2500	105-006	585-920

^ - Socket set screw location does not conform to ANSI specification. Request information if set screw location is critical

(1), (2) - These are recommended pressures. Lower coolant pressures may be utilized at very slow RPM's. Pressures above recommended PSI may cause internal damage to seals.

(3) - Recommended Maximum RPM at Maximum 1000 PSI. Higher speeds may be achieved at lower pressures.

These RPM and Pressure ranges are not a guarantee of performance. The life and performance of the units depends on the following conditions:

Proper Filtration - Proper Type & Viscosity of Coolant - Coolant Pressure and Volume.

All units require coolant at all speeds.

BT MORSE TAPER HOLDERS • SINGLE PIN FACE SEAL ROTARY COOLANT GLAND

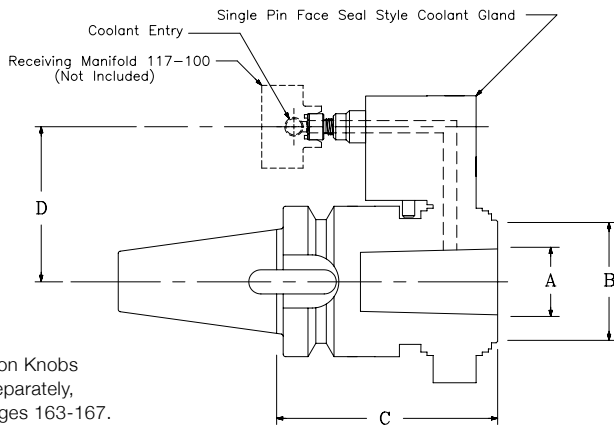

Retention Knobs
Sold Separately,
See Pages 163-167.

ASSEMBLY PART NUMBER	A MORSE TAPER	CLEARANCE DIA. (IN.)	C PROJECTION (IN.)	D CTR TO CTR (IN.)	COOLANT GLAND (INCLUDED)	MINIMUM COOLANT PRESSURE (1)	MAXIMUM COOLANT PRESSURE (2)	MAXIMUM SPEED (RPM) (3)	REPLACEMENT SEAL KIT PART NUMBER (NOT INCLUDED)	
BT 40										
BT40-MT2-SPFS-5	MT2	2.125	4.50	2.559	AI-9889N	100 PSI	1000 PSI	3000	585-916	
BT40-MT3-SPFS-5	MT3	2.125	4.50	2.559	AI-9889N	100 PSI	1000 PSI	3000	585-916	
BT40-MT4-SPFS-5	MT4	2.125	4.50	2.559	AI-9889N	100 PSI	1000 PSI	3000	585-916	
BT 50										
BT50-MT3-SPFS-5	MT3	2.500	4.50	3.150	AI-9989S	100 PSI	1000 PSI	2500	585-920	
BT50-MT4-SPFS-5	MT4	2.500	4.50	3.150	AI-9989S	100 PSI	1000 PSI	2500	585-920	
BT50-MT5-SPFS-5	MT5	2.500	4.50	3.150	AI-9989S	100 PSI	1000 PSI	2500	585-920	

(1), (2) - These are recommended pressures. Lower coolant pressures may be utilized at very slow RPM's. Pressures above recommended PSI may cause internal damage to seals.

(3) - Recommended Maximum RPM at Maximum 1000 PSI. Higher speeds may be achieved at lower pressures.

These RPM and Pressure ranges are not a guarantee of performance. The life and performance of the units depends on the following conditions:

Proper Filtration - Proper Type & Viscosity of Coolant - Coolant Pressure and Volume.

All units require coolant at all speeds.



V-FLANGE SINGLE ANGLE COLLET CHUCK • SINGLE PIN O-RING ROTARY COOLANT GLAND

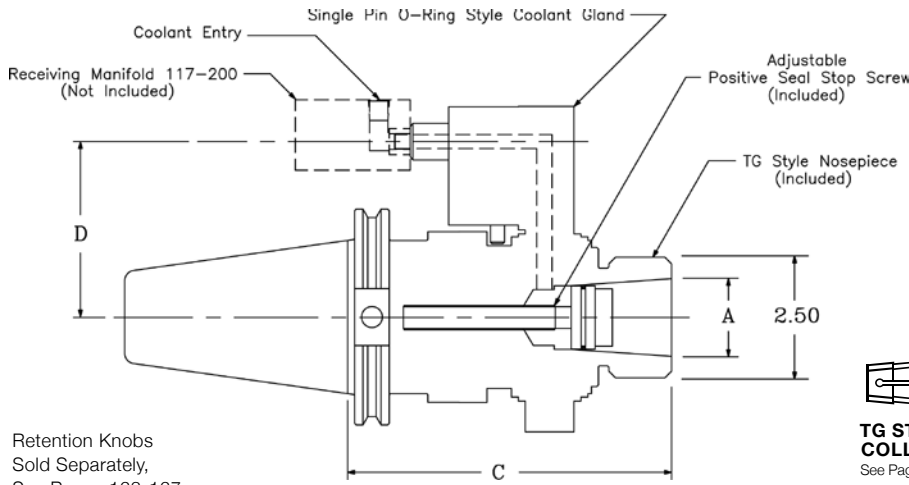

TG STYLE COLLETS
See Page 146.

•See page 111 for positive seal stop screw.

ASSEMBLY PART NUMBER	A RANGE (IN.)	COLLET SERIES	CLEARANCE DIA. (IN.)	C PROJ. (IN.)	D CTR TO CTR (IN.)	COOLANT GLAND (INCLUDED)	MINIMUM COOLANT PRESSURE (1)	MAXIMUM COOLANT PRESSURE (2)	MAXIMUM SPEED (RPM) (3)	OPTIONAL EXTENSION STYLE STOP SCREW (NOT INCLUDED)	REPLACEMENT SEAL KIT PART NUMBER (NOT INCLUDED)	SPANNER WRENCH (NOT INCLUDED)
40 V-FLANGE												
C40-TG10-SPOR-6	0.094 - 1.000	TG 100	2.50	6.00	2.559	V-7419M	100 PSI	1000 PSI	3000	116-004	585-916	112-001

(1), (2) - These are recommended pressures. Lower coolant pressures may be utilized at very slow RPM's. Pressures above recommended PSI may cause internal damage to seals.
 (3) - Recommended Maximum RPM at Maximum 1000 PSI. Higher speeds may be achieved at lower pressures.
These RPM and Pressure ranges are not a guarantee of performance. The life and performance of the units depends on the following conditions:
 Proper Filtration - Proper Type & Viscosity of Coolant - Coolant Pressure and Volume.
All units require coolant at all speeds.

AUTO TOOL CHANGE : ATC

V-FLANGE DOUBLE ANGLE COLLET CHUCK • SINGLE PIN O-RING ROTARY COOLANT GLAND

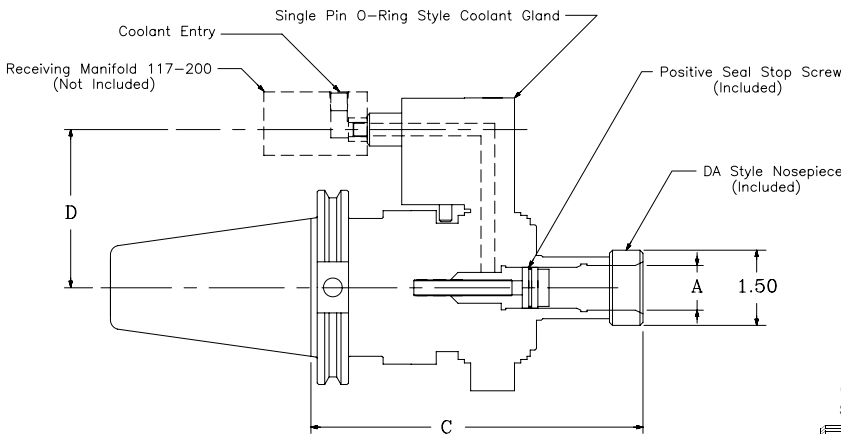

DA STYLE COLLETS
See Page 147.

•See page 111 for positive seal stop screw.

ASSEMBLY PART NUMBER	A RANGE (IN.)	COLLET SERIES	CLEARANCE DIA. (IN.)	C PROJECTION (IN.)	D CTR TO CTR (IN.)	COOLANT GLAND (INCLUDED)	MINIMUM COOLANT PRESSURE (1)	MAXIMUM COOLANT PRESSURE (2)	MAXIMUM SPEED (RPM) (3)	REPLACEMENT SEAL KIT PART NUMBER (NOT INCLUDED)	SPANNER WRENCH (NOT INCLUDED)
40 V-FLANGE											
*C40-DA18-SPOR-7	0.047 - 0.750	DA 180	1.50	7.00	2.559	V-7419B	100 PSI	1000 PSI	4000	585-904	112-019

*** Outgoing Items**

(1), (2) - These are recommended pressures. Lower coolant pressures may be utilized at very slow RPM's. Pressures above recommended PSI may cause internal damage to seals.
 (3) - Recommended Maximum RPM at Maximum 1000 PSI. Higher speeds may be achieved at lower pressures.
These RPM and Pressure ranges are not a guarantee of performance. The life and performance of the units depends on the following conditions:
 Proper Filtration - Proper Type & Viscosity of Coolant - Coolant Pressure and Volume.
All units require coolant at all speeds.



V-FLANGE END MILL HOLDERS • SINGLE PIN O-RING ROTARY COOLANT GLAND

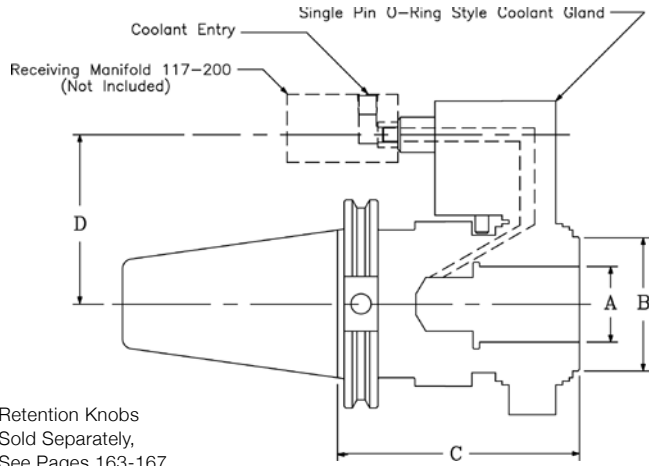

Retention Knobs
Sold Separately,
See Pages 163-167.

ASSEMBLY PART NUMBER	A I.D. (IN.)	CLEARANCE DIA. (IN.)	C PROJ. (IN.)	D CTR TO CTR (IN.)	COOLANT GLAND (INCLUDED)	MINIMUM COOLANT PRESSURE (1)	MAXIMUM COOLANT PRESSURE (2)	MAXIMUM SPEED (RPM) (3)	COOLANT STOP SCREW (INCLUDED)	REPLACEMENT SEAL KIT PART NUMBER (NOT INCLUDED)
40 V-FLANGE										
C40-EM75-SPOR-6	0.750	1.312	5.50	2.559	V-7419B	100 PSI	1000 PSI	4000	NONE	585-904
C40-EM10-SPOR-6	1.000	1.625	5.50	2.559	V-7419J	100 PSI	1000 PSI	3300	NONE	585-912
^C40-EM12-SPOR-5	1.250	2.125	4.50	2.559	V-7419M	100 PSI	1000 PSI	3000	105-005	585-916

^ - Socket set screw location does not conform to ANSI specification. Request information if set screw location is critical

(1), (2) - These are recommended pressures. Lower coolant pressures may be utilized at very slow RPM's. Pressures above recommended PSI may cause internal damage to seals.
(3) - Recommended Maximum RPM at Maximum 1000 PSI. Higher speeds may be achieved at lower pressures.

These RPM and Pressure ranges are not a guarantee of performance. The life and performance of the units depends on the following conditions:
Proper Filtration - Proper Type & Viscosity of Coolant - Coolant Pressure and Volume.
All units require coolant at all speeds.

V-FLANGE ABS® STYLE HOLDERS • SINGLE PIN O-RING ROTARY COOLANT GLAND

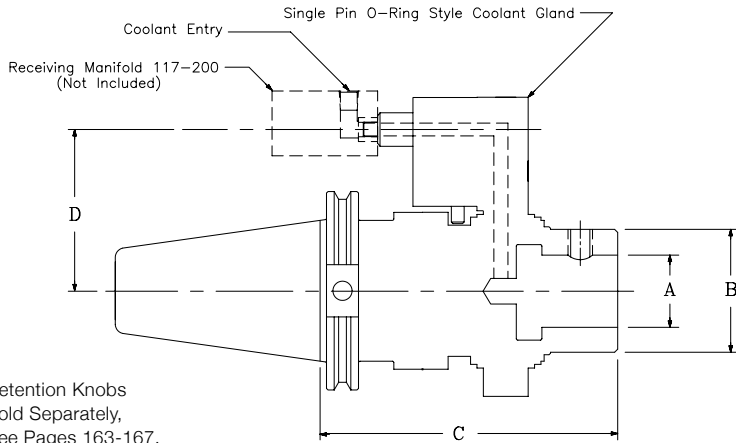

Retention Knobs
Sold Separately,
See Pages 163-167.

ASSEMBLY PART NUMBER	A ABS® CONNECTION	B CLEARANCE DIA. (IN.)	C PROJ. (IN.)	D CTR TO CTR (IN.)	COOLANT GLAND (INCLUDED)	MINIMUM COOLANT PRESSURE(1)	MAXIMUM COOLANT PRESSURE(2)	MAXIMUM SPEED (RPM)(3)	REPLACEMENT SEAL KIT PART NUMBER (NOT INCLUDED)
40 V-FLANGE									
C40-ABS40-SPOR-6	ABS 40	1.625	5.25	2.559	V-7419J	100 PSI	1000 PSI	3300	585-912
C40-ABS50-SPOR-6	ABS 50	2.125	5.50	2.559	V-7419M	100 PSI	1000 PSI	3000	585-916

• Please refer to the Modular Tooling Section on pages 140-143 for Modular Adapters

ABS® is a registered trademark of KOMET.

(1), (2) - These are recommended pressures. Lower coolant pressures may be utilized at very slow RPM's. Pressures above recommended PSI may cause internal damage to seals.
(3) - Recommended Maximum RPM at Maximum 1000 PSI. Higher speeds may be achieved at lower pressures.

These RPM and Pressure ranges are not a guarantee of performance. The life and performance of the units depends on the following conditions:
Proper Filtration - Proper Type & Viscosity of Coolant - Coolant Pressure and Volume.
All units require coolant at all speeds.



V-FLANGE MORSE TAPER HOLDERS • SINGLE PIN O-RING ROTARY COOLANT GLAND

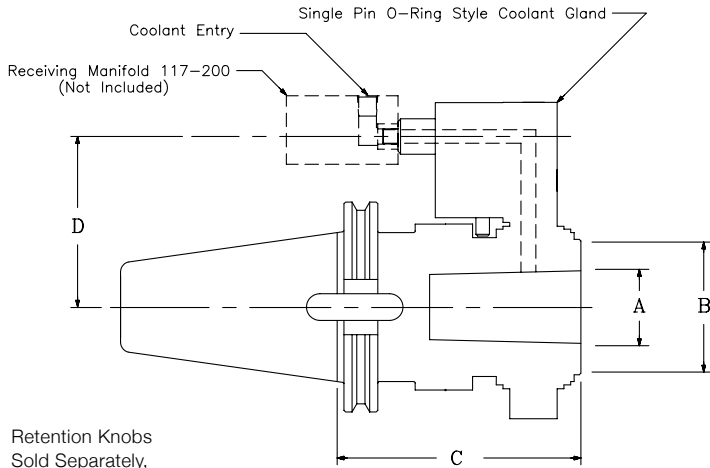

Retention Knobs
Sold Separately,
See Pages 163-167.



ASSEMBLY PART NUMBER	A MORSE TAPER	B CLEARANCE DIA. (IN.)	C PROJ. (IN.)	D CTR TO CTR (IN.)	COOLANT GLAND (INCLUDED)	MINIMUM COOLANT PRESSURE (1)	MAXIMUM COOLANT PRESSURE (2)	MAXIMUM SPEED (RPM) (3)	REPLACEMENT SEAL KIT PART NUMBER (NOT INCLUDED)
40 V-FLANGE									
C40-MT3-SPOR-5	MT3	2.125	4.50	2.559	V-7419M	100 PSI	1000 PSI	3000	585-916
C40-MT3-SPOR-5A	MT3	1.312	4.50	2.559	V-7419B	100 PSI	1000 PSI	4000	585-904
C40-MT4-SPOR-5	MT4	2.125	4.50	2.559	V-7419M	100 PSI	1000 PSI	3000	585-916
C40-MT4-SPOR-5A	MT4	1.312	4.50	2.559	V-7419B	100 PSI	1000 PSI	4000	585-904

(1), (2) - These are recommended pressures. Lower coolant pressures may be utilized at very slow RPM's. Pressures above recommended PSI may cause internal damage to seals.
(3) - Recommended Maximum RPM at Maximum 1000 PSI. Higher speeds may be achieved at lower pressures.

These RPM and Pressure ranges are not a guarantee of performance. The life and performance of the units depends on the following conditions:

Proper Filtration - Proper Type & Viscosity of Coolant - Coolant Pressure and Volume.

All units require coolant at all speeds.

AUTO TOOL
CHANGE - ATC

BT SINGLE ANGLE COLLET CHUCK • SINGLE PIN O-RING ROTARY COOLANT GLAND

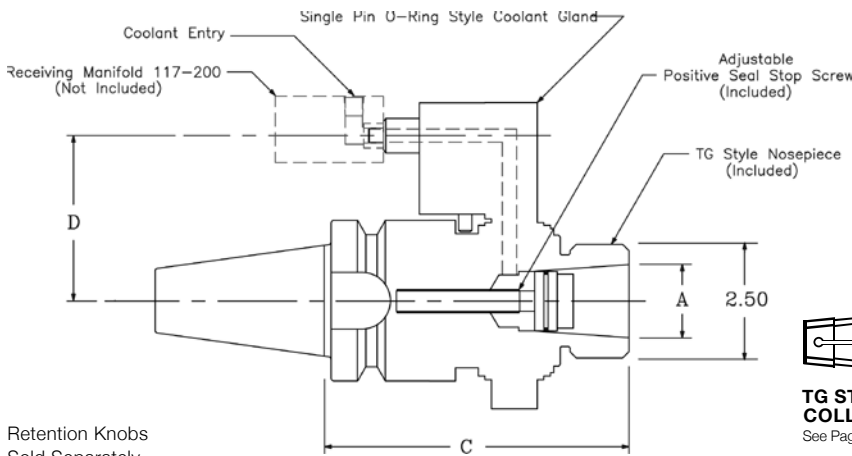

Retention Knobs
Sold Separately,
See Pages 163-167.



TG STYLE COLLETS
See Page 146.

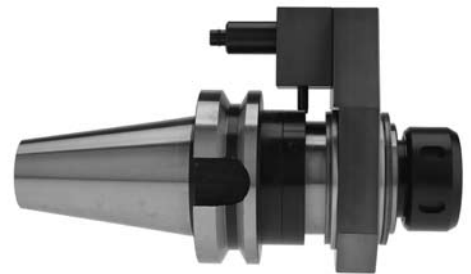

•See page 111 for positive seal stop screw.

ASSEMBLY PART NUMBER	A RANGE (IN.)	COLLET SERIES	CLEARANCE DIA. (IN.)	C PROJ. (IN.)	D CTR TO CTR (IN.)	COOLANT GLAND (INCLUDED)	MINIMUM COOLANT PRESSURE (1)	MAXIMUM COOLANT PRESSURE (2)	MAXIMUM SPEED (RPM) (3)	OPTIONAL EXTENSION STYLE STOP SCREW (NOT INCLUDED)	REPLACEMENT SEAL KIT PART NUMBER (NOT INCLUDED)	SPANNER WRENCH (NOT INCLUDED)
BT 40												
BT40-TG10-SPOR-6	0.094 - 1.000	TG 100	2.50	5.25	2.559	V-7419M	100 PSI	1000 PSI	3000	116-004	585-916	112-001

(1), (2) - These are recommended pressures. Lower coolant pressures may be utilized at very slow RPM's. Pressures above recommended PSI may cause internal damage to seals.

(3) - Recommended Maximum RPM at Maximum 1000 PSI. Higher speeds may be achieved at lower pressures.

These RPM and Pressure ranges are not a guarantee of performance. The life and performance of the units depends on the following conditions:

Proper Filtration - Proper Type & Viscosity of Coolant - Coolant Pressure and Volume.

All units require coolant at all speeds.



BT END MILL HOLDERS • SINGLE PIN O-RING ROTARY COOLANT GLAND

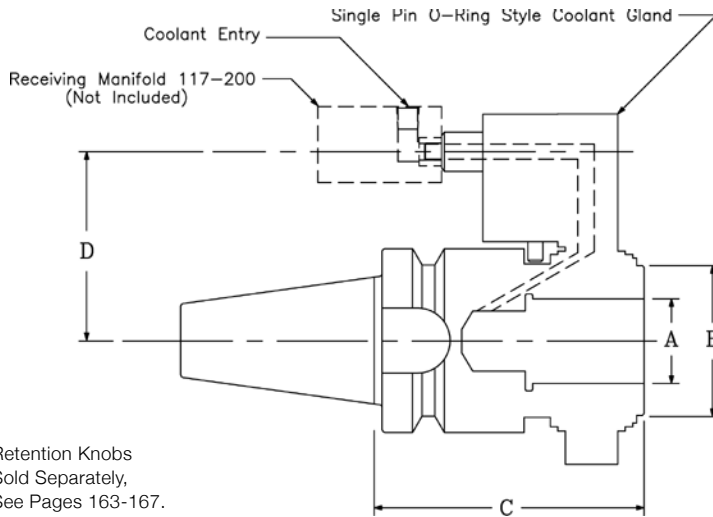

Retention Knobs
Sold Separately,
See Pages 163-167.

ASSEMBLY PART NUMBER	A I.D. (IN.)	B CLEARANCE DIA. (IN.)	C PROJ. (IN.)	D CTR TO CTR (IN.)	COOLANT GLAND (INCLUDED)	MINIMUM COOLANT PRESSURE (1)	MAXIMUM COOLANT PRESSURE (2)	MAXIMUM SPEED (RPM) (3)	COOLANT STOP SCREW (INCLUDED)	REPLACEMENT SEAL KIT PART NUMBER (NOT INCLUDED)
BT 40										
BT40-EM75-SPOR-6	0.750	1.312	5.50	2.559	V-7419B	100 PSI	1000 PSI	4000	105-007	585-904
BT40-EM10-SPOR-5	1.000	2.125	4.50	2.559	V-7419M	100 PSI	1000 PSI	3000	105-007	585-916
^BT40-EM12-SPOR-5	1.250	2.125	4.50	2.559	V-7419M	100 PSI	1000 PSI	3000	105-007	585-916

^ - Socket set screw location does not conform to ANSI specification. Request information if set screw location is critical.

(1), (2) - These are recommended pressures. Lower coolant pressures may be utilized at very slow RPM's. Pressures above recommended PSI may cause internal damage to seals.
(3) - Recommended Maximum RPM at Maximum 1000 PSI. Higher speeds may be achieved at lower pressures.

These RPM and Pressure ranges are not a guarantee of performance. The life and performance of the units depends on the following conditions:
Proper Filtration - Proper Type & Viscosity of Coolant - Coolant Pressure and Volume.
All units require coolant at all speeds.

BT MORSE TAPER HOLDERS • SINGLE PIN O-RING ROTARY COOLANT GLAND

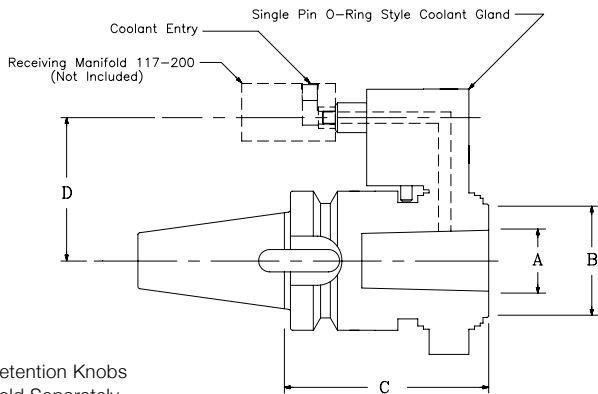

Retention Knobs
Sold Separately,
See Pages 163-167.

ASSEMBLY PART NUMBER	A MORSE TAPER	B CLEARANCE DIA. (IN.)	C PROJECTION (IN.)	D CTR TO CTR (IN.)	COOLANT GLAND (INCLUDED)	MINIMUM COOLANT PRESSURE (1)	MAXIMUM COOLANT PRESSURE (2)	MAXIMUM SPEED (RPM) (3)	REPLACEMENT SEAL KIT PART NUMBER (NOT INCLUDED)
BT 40									
BT40-MT2-SPOR-5	MT2	2.125	4.50	2.559	V-7419M	100 PSI	1000 PSI	3000	585-916
BT40-MT3-SPOR-5	MT3	2.125	4.50	2.559	V-7419M	100 PSI	1000 PSI	3000	585-916
BT40-MT4-SPOR-5	MT4	2.125	4.50	2.559	V-7419M	100 PSI	1000 PSI	3000	585-916

(1), (2) - These are recommended pressures. Lower coolant pressures may be utilized at very slow RPM's. Pressures above recommended PSI may cause internal damage to seals.
(3) - Recommended Maximum RPM at Maximum 1000 PSI. Higher speeds may be achieved at lower pressures.

These RPM and Pressure ranges are not a guarantee of performance. The life and performance of the units depends on the following conditions:
Proper Filtration - Proper Type & Viscosity of Coolant - Coolant Pressure and Volume.
All units require coolant at all speeds.



V-FLANGE SINGLE ANGLE COLLET CHUCK • DUAL PIN O-RING ROTARY COOLANT GLAND

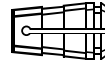
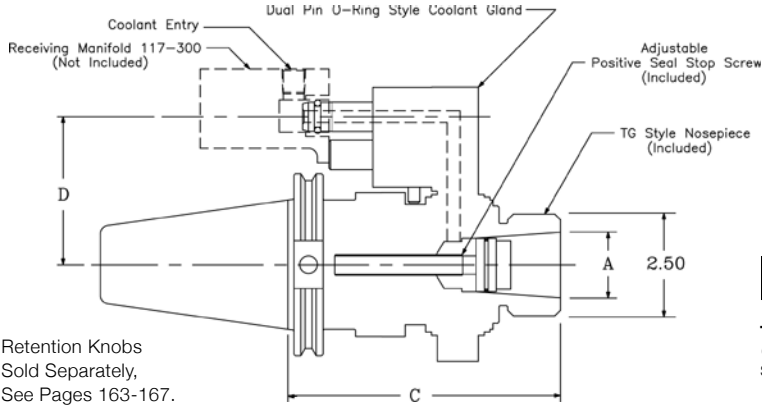

TG STYLE COLLETS
See Page 146.



•See page 111 for positive seal stop screw.

ASSEMBLY PART NUMBER	A RANGE (IN.)	COLLET SERIES	CLEARANCE DIAMETER (IN.)	C PROJ. (IN.)	D CTR TO CTR (IN.)	COOLANT GLAND (INCLUDED)	MINIMUM COOLANT PRESSURE (1)	MAXIMUM COOLANT PRESSURE (2)	MAXIMUM SPEED (RPM) (3)	OPTIONAL EXTENSION STYLE STOP SCREW (NOT INCLUDED)	REPLACEMENT SEAL KIT PART NUMBER (NOT INCLUDED)	SPANNER WRENCH (NOT INCLUDED)
45 V-FLANGE												
*C45-TG10-DPOR-6	0.094 - 1.000	TG 100	2.500	6.00	3.150	E-7353S	100 PSI	1000 PSI	2500	116-001	585-920	112-001
50 V-FLANGE												
C50-TG10-DPOR-6	0.094 - 1.000	TG 100	2.500	6.00	3.150	E-7353S	100 PSI	1000 PSI	2500	116-001	585-920	112-001

* Outgoing Items

(1), (2) - These are recommended pressures. Lower coolant pressures may be utilized at very slow RPM's. Pressures above recommended PSI may cause internal damage to seals.
(3) - Recommended Maximum RPM at Maximum 1000 PSI. Higher speeds may be achieved at lower pressures.

These RPM and Pressure ranges are not a guarantee of performance. The life and performance of the units depends on the following conditions:

Proper Filtration - Proper Type & Viscosity of Coolant - Coolant Pressure and Volume.

All units require coolant at all speeds.

AUTO TOOL
CHANGE : ATC

V-FLANGE END MILL HOLDERS • DUAL PIN O-RING ROTARY COOLANT GLAND

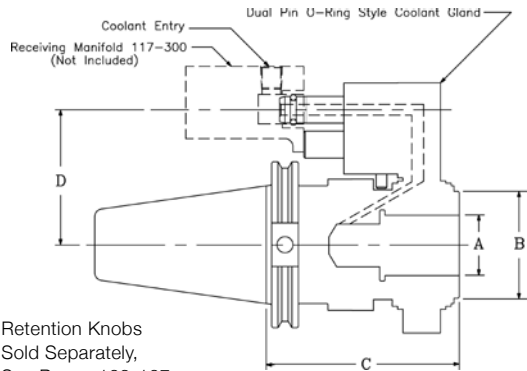

Retention Knobs
Sold Separately,
See Pages 163-167.

ASSEMBLY PART NUMBER	A I.D. (IN.)	B CLEARANCE DIA. (IN.)	C PROJECTION (IN.)	D CTR TO CTR (IN.)	COOLANT GLAND (INCLUDED)	MINIMUM COOLANT PRESSURE (1)	MAXIMUM COOLANT PRESSURE (2)	MAXIMUM SPEED (RPM) (3)	COOLANT STOP SCREW (NOT INCLUDED)	REPLACEMENT SEAL KIT PART NUMBER (NOT INCLUDED)
45 V-FLANGE										
*C45-EM75-DPOR-5	0.750	1.312	4.50	3.150	E-7353B	100 PSI	1000 PSI	4000	NONE	585-904
*C45-EM10-DPOR-5	1.000	1.625	4.50	3.150	E-7353D	100 PSI	1000 PSI	3300	NONE	585-912
^C45-EM12-DPOR-5	1.250	2.500	4.50	3.150	E-7353S	100 PSI	1000 PSI	2500	105-003	585-920
^C45-EM15-DPOR-5	1.500	2.500	4.50	3.150	E-7353S	100 PSI	1000 PSI	2500	105-003	585-920
50 V-FLANGE										
C50-EM75-DPOR-6	0.750	1.312	5.50	3.150	E-7353B	100 PSI	1000 PSI	4000	NONE	585-904
C50-EM10-DPOR-6	1.000	1.625	5.50	3.150	E-7353D	100 PSI	1000 PSI	3300	NONE	585-912
^C50-EM12-DPOR-5	1.250	2.500	4.50	3.150	E-7353S	100 PSI	1000 PSI	2500	105-004	585-920
^C50-EM15-DPOR-5	1.500	2.500	4.50	3.150	E-7353S	100 PSI	1000 PSI	2500	105-004	585-920

* Outgoing Items

^ - Socket set screw location does not conform to ANSI specification. Request information if set screw location is critical.

(1), (2) - These are recommended pressures. Lower coolant pressures may be utilized at very slow RPM's. Pressures above recommended PSI may cause internal damage to seals.

(3) - Recommended Maximum RPM at Maximum 1000 PSI. Higher speeds may be achieved at lower pressures.

These RPM and Pressure ranges are not a guarantee of performance. The life and performance of the units depends on the following conditions:

Proper Filtration - Proper Type & Viscosity of Coolant - Coolant Pressure and Volume.

All units require coolant at all speeds.



V-FLANGE ABS® STYLE HOLDERS • DUAL PIN O-RING ROTARY COOLANT GLAND

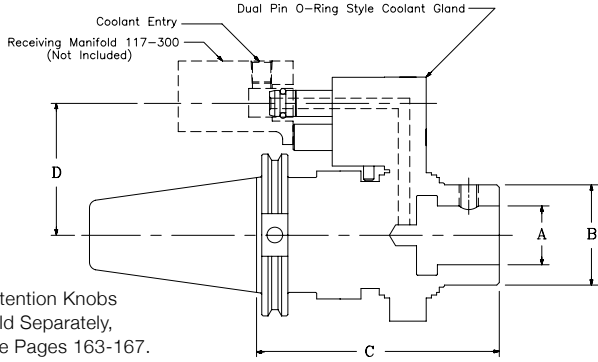

ASSEMBLY PART NUMBER	A ABS® CONNECTION	B CLEARANCE DIA. (IN.)	C PROJECTION (IN.)	D CTR TO CTR (IN.)	COOLANT GLAND (INCLUDED)	MINIMUM COOLANT PRESSURE (1)	MAXIMUM COOLANT PRESSURE (2)	MAXIMUM SPEED (RPM) (3)	REPLACEMENT SEAL KIT PART NUMBER (NOT INCLUDED)
45 V-FLANGE									
*C45-ABS40-DPOR-6	ABS 40	1.625	5.25	3.150	E-7353D	100 PSI	1000 PSI	3300	585-912
*C45-ABS50-DPOR-6	ABS 50	2.125	5.50	3.150	E-7353X	100 PSI	1000 PSI	3000	585-916
*C45-ABS63-DPOR-6	ABS 63	2.500	5.62	3.150	E-7353S	100 PSI	1000 PSI	2500	585-920
50 V-FLANGE ^									
C50-ABS40-DPOR-6	ABS 40	1.625	5.25	3.150	E-7353D	100 PSI	1000 PSI	3300	585-912
C50-ABS50-DPOR-6	ABS 50	2.125	5.50	3.150	E-7353X	100 PSI	1000 PSI	3000	585-916
C50-ABS63-DPOR-5	ABS 63	2.500	5.75	3.150	E-7353S	100 PSI	1000 PSI	2500	585-920

* **Outgoing Items** ^ - ABS 80 & ABS 100 holders available by special quotation on 50 V-Flange units.

ABS® is a registered trademark of KOMET.

• Please refer to the Modular Tooling Section on pages 140-143 for Modular Adapters

(1), (2) - These are recommended pressures. Lower coolant pressures may be utilized at very slow RPM's. Pressures above recommended PSI may cause internal damage to seals.

(3) - Recommended Maximum RPM at Maximum 1000 PSI. Higher speeds may be achieved at lower pressures.

These RPM and Pressure ranges are not a guarantee of performance. The life and performance of the units depends on the following conditions:

Proper Filtration - Proper Type & Viscosity of Coolant - Coolant Pressure and Volume.

All units require coolant at all speeds.

V-FLANGE MORSE TAPER HOLDERS • DUAL PIN O-RING ROTARY COOLANT GLAND

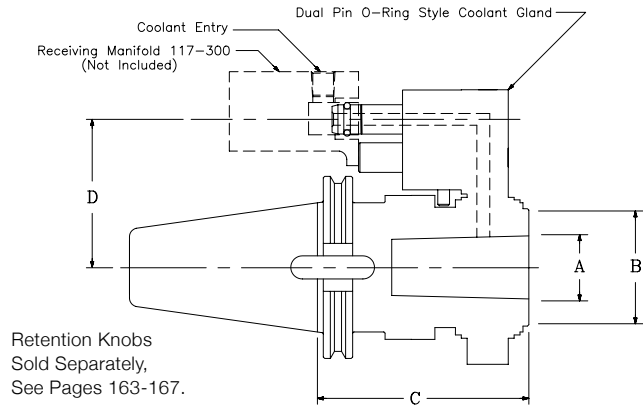

ASSEMBLY PART NUMBER	A MORSE TAPER	B CLEARANCE DIA. (IN.)	C PROJECTION (IN.)	D CTR TO CTR (IN.)	COOLANT GLAND (INCLUDED)	MINIMUM COOLANT PRESSURE (1)	MAXIMUM COOLANT PRESSURE (2)	MAXIMUM SPEED (RPM) (3)	REPLACEMENT SEAL KIT PART NUMBER (NOT INCLUDED)
45 V-FLANGE									
*C45-MT3-DPOR-5	MT3	2.500	4.50	3.150	E-7353S	100 PSI	1000 PSI	2500	585-920
*C45-MT3-DPOR-5A	MT3	1.312	4.50	3.150	E-7353B	100 PSI	1000 PSI	4000	585-904
*C45-MT4-DPOR-5	MT4	2.500	4.50	3.150	E-7353S	100 PSI	1000 PSI	2500	585-920
*C45-MT4-DPOR-5A	MT4	1.312	4.50	3.150	E-7353B	100 PSI	1000 PSI	4000	585-904
50 V-FLANGE									
C50-MT3-DPOR-5	MT3	2.500	4.50	3.150	E-7353S	100 PSI	1000 PSI	2500	585-920
C50-MT3-DPOR-5A	MT3	1.312	4.50	3.150	E-7353B	100 PSI	1000 PSI	4000	585-904
C50-MT4-DPOR-5	MT4	2.500	4.50	3.150	E-7353S	100 PSI	1000 PSI	2500	585-920
C50-MT4-DPOR-5A	MT4	1.312	4.50	3.150	E-7353B	100 PSI	1000 PSI	4000	585-904
C50-MT5-DPOR-5	MT5	2.500	4.50	3.150	E-7353S	100 PSI	1000 PSI	2500	585-920

* **Outgoing Items**

(1), (2) - These are recommended pressures. Lower coolant pressures may be utilized at very slow RPM's. Pressures above recommended PSI may cause internal damage to seals.

(3) - Recommended Maximum RPM at Maximum 1000 PSI. Higher speeds may be achieved at lower pressures.

These RPM and Pressure ranges are not a guarantee of performance. The life and performance of the units depends on the following conditions:

Proper Filtration - Proper Type & Viscosity of Coolant - Coolant Pressure and Volume.

All units require coolant at all speeds.



V-FLANGE 2 PIECE SINGLE ANGLE COLLET CHUCK • DUAL PIN O-RING ROTARY COOLANT GLAND

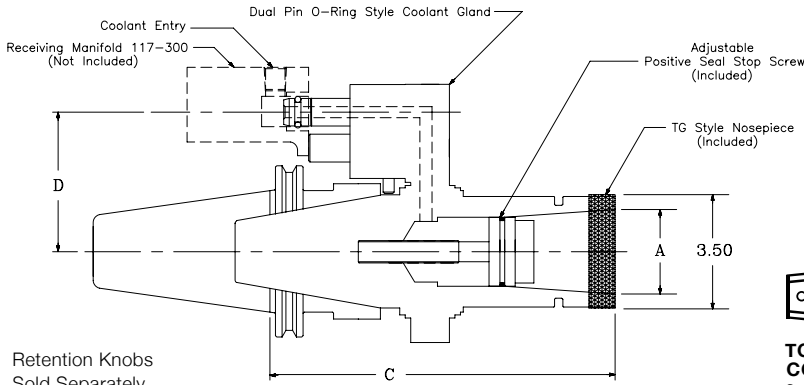

Retention Knobs
Sold Separately,
See Pages 163-167.

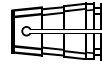

TG STYLE COLLETS
See Page 146.



• See page 111 for positive seal stop screw.

ASSEMBLY PART NUMBER	A RANGE (IN.)	COLLET SERIES	CLEARANCE DIA. (IN.)	C PROJ. (IN.)	D CTR TO CTR (IN.)	COOLANT GLAND (INCLUDED)	MINIMUM COOLANT PRESSURE (1)	MAXIMUM COOLANT PRESSURE (2)	MAXIMUM SPEED (RPM) (3)	REPLACEMENT SEAL KIT PART NUMBER (NOT INCLUDED)	SPANNER WRENCH (NOT INCLUDED)
50 V-FLANGE											
C50-TG15-2P-DPOR-9	0,500 - 1,500	TG 150	3,50	8,38	3,150	E-7353S	100 PSI	1000 PSI	2500	585-920	112-002

• Especially designed to suit large shanked tools in a CNC carousel with limited space. • Utilizes standard coolant gland assemblies.

(1), (2) - These are recommended pressures. Lower coolant pressures may be utilized at very slow RPM's. Pressures above recommended PSI may cause internal damage to seals.
(3) - Recommended Maximum RPM at Maximum 1000 PSI. Higher speeds may be achieved at lower pressures.

These RPM and Pressure ranges are not a guarantee of performance. The life and performance of the units depends on the following conditions:
Proper Filtration - Proper Type & Viscosity of Coolant - Coolant Pressure and Volume.
All units require coolant at all speeds.

AUTO TOOL CHANGE : ATC

V-FLANGE 2 PIECE END MILL HOLDERS • DUAL PIN O-RING ROTARY COOLANT GLAND

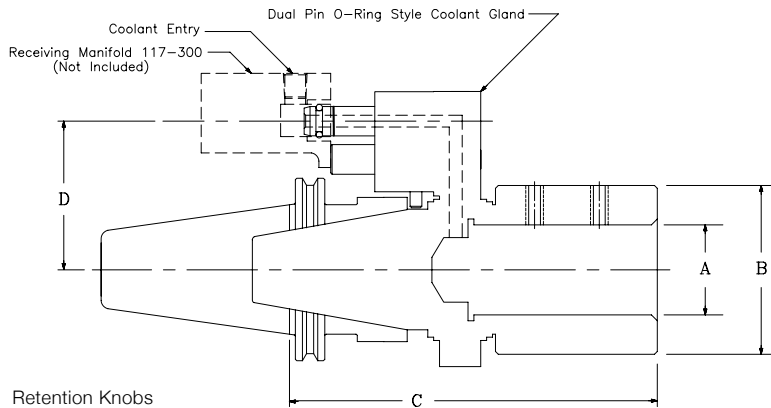

Retention Knobs
Sold Separately,
See Pages 163-167.



ASSEMBLY PART NUMBER	A I.D. (IN.)	B CLEARANCE DIA. (IN.)	C PROJECTION (IN.)	D CTR TO CTR (IN.)	COOLANT GLAND (INCLUDED)	MINIMUM COOLANT PRESSURE (1)	MAXIMUM COOLANT PRESSURE (2)	MAXIMUM SPEED (RPM) (3)	REPLACEMENT SEAL KIT PART NUMBER (NOT INCLUDED)
50 V-FLANGE									
C50-EM17-2P-DPOR-9	1,750	3,750	8,25	3,150	E-7353S	100 PSI	1000 PSI	2500	585-920
C50-EM20-2P-DPOR-9	2,000	3,750	8,25	3,150	E-7353S	100 PSI	1000 PSI	2500	585-920
C50-EM22-2P-DPOR-9	2,250	4,000	8,25	3,150	E-7353S	100 PSI	1000 PSI	2500	585-920
C50-EM25-2P-DPOR-9	2,500	4,000	8,25	3,150	E-7353S	100 PSI	1000 PSI	2500	585-920

• Especially designed to suit large shanked tools in a CNC carousel with limited space. • Utilizes standard coolant gland assemblies.

(1), (2) - These are recommended pressures. Lower coolant pressures may be utilized at very slow RPM's. Pressures above recommended PSI may cause internal damage to seals.
(3) - Recommended Maximum RPM at Maximum 1000 PSI. Higher speeds may be achieved at lower pressures.

These RPM and Pressure ranges are not a guarantee of performance. The life and performance of the units depends on the following conditions:
Proper Filtration - Proper Type & Viscosity of Coolant - Coolant Pressure and Volume.
All units require coolant at all speeds.



KEARNEY & TRECKER SINGLE ANGLE COLLET CHUCK • DUAL PIN O-RING ROTARY COOLANT GLAND

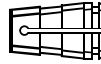
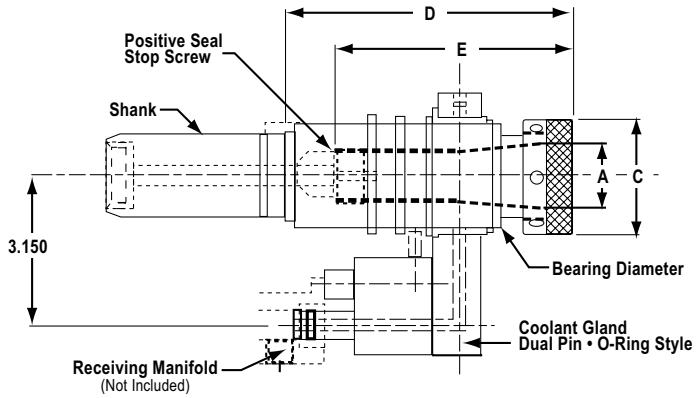

TG STYLE COLLETS
See Page 146.

ASSEMBLY PART NUMBER	A RANGE (IN.)	COLLET SERIES	BEARING DIA. (IN.)	C CLEARANCE (IN.)	D PROJ. (IN.)	E MAX DEPTH (IN.)	COOLANT GLAND (INCLUDED)	MINIMUM COOLANT PRESSURE (1)	MAXIMUM COOLANT PRESSURE (2)	POSITIVE SEAL STOP SCREW (INCLUDED)	REPLACEMENT SEAL KIT PART NUMBER (NOT INCLUDED)	SPANNER WRENCH (NOT INCLUDED)
200 SERIES												
*KT200-TG10-DPOR-6P	0.094 - 1.000	TG 100	2.125	2.50	6.00	5.50	E-7353X	100 PSI	1000 PSI	104-001	585-916	112-001
300 SERIES												
*KT300-TG10-DPOR-6P	0.094 - 1.000	TG 100	2.500	2.50	6.00	5.50	E-7353S	100 PSI	1000 PSI	102-003	585-920	112-001

*** Outgoing Items**

• All Kearney & Trecker holders are furnished with coolant stop screws, location keys and code ring locknuts

(1),(2) - These are recommended pressures. Lower coolant pressures may be utilized at very slow RPM's. Pressures above recommended. PSI may cause internal damage to seals.

(3) - Recommended Maximum RPM at Maximum 1000 PSI. Higher speeds may be achieved at lower pressures.

These RPM and Pressure ranges are not a guarantee of performance. The life and performance of the units depends on the following conditions:

Proper Filtration - Proper Type & Viscosity of Coolant - Coolant Pressure and Volume.

All units require coolant at all speeds.

KEARNEY & TRECKER END MILL HOLDERS • DUAL PIN O-RING ROTARY COOLANT GLAND

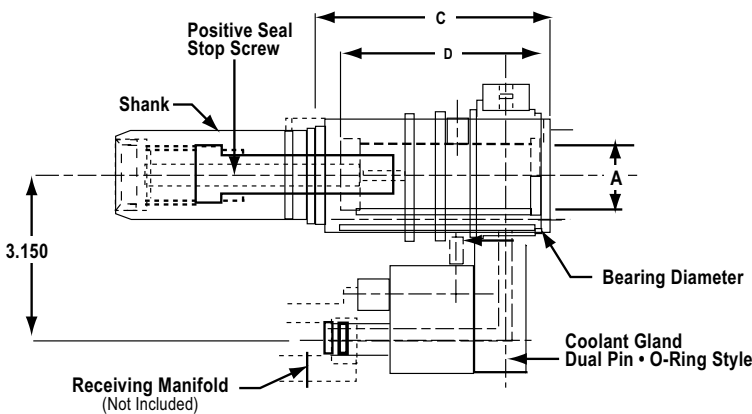

ASSEMBLY PART NUMBER	A BORE (IN.)	BEARING DIA. (IN)	C PROJ. (IN)	D MAX DEPTH (IN)	COOLANT GLAND (INCLUDED)	MINIMUM COOLANT PRESSURE (1)	MAXIMUM COOLANT PRESSURE (2)	COOLANT STOP SCREW (INCLUDED)	REPLACEMENT SEAL KIT PART NUMBER (NOT INCLUDED)
200 SERIES									
*KT200-EM12-DPOR-5	1.25	2.125	4.50	4.00	E-7353X	100 PSI	1000 PSI	105-001	585-916
300 SERIES									
*KT300-EM12-DPOR-5	1.25	2.500	4.50	4.00	E-7353S	100 PSI	1000 PSI	105-002	585-920
*KT300-EM15-DPOR-5	1.50	2.500	4.50	4.00	E-7353S	100 PSI	1000 PSI	105-002	585-920

*** Outgoing Items**

• All Kearney & Trecker holders are furnished with coolant stop screws, location keys and code ring locknuts

(1),(2) - These are recommended pressures. Lower coolant pressures may be utilized at very slow RPM's. Pressures above recommended. PSI may cause internal damage to seals.

(3) - Recommended Maximum RPM at Maximum 1000 PSI. Higher speeds may be achieved at lower pressures.

These RPM and Pressure ranges are not a guarantee of performance. The life and performance of the units depends on the following conditions:

Proper Filtration - Proper Type & Viscosity of Coolant - Coolant Pressure and Volume.

All units require coolant at all speeds.



BT SINGLE ANGLE COLLET CHUCK • DUAL PIN O-RING ROTARY COOLANT GLAND

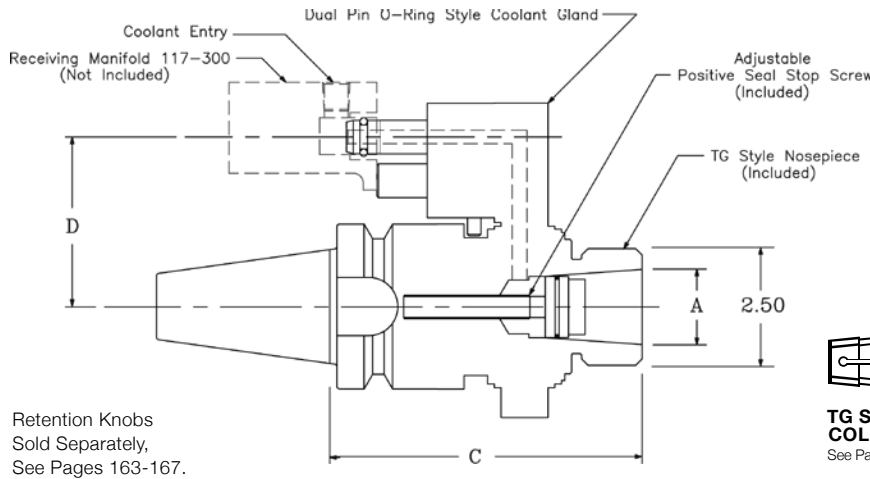

• See page 111 for positive seal stop screw.

ASSEMBLY PART NUMBER	A RANGE (IN.)	COLLET SERIES	CLEARANCE DIA. (IN.)	C PROJ. (IN.)	D CTR TO CTR (IN.)	COOLANT GLAND (INCLUDED)	MINIMUM COOLANT PRESSURE (1)	MAXIMUM COOLANT PRESSURE (2)	MAXIMUM SPEED (RPM) (3)	OPTIONAL EXTENSION STYLE STOP SCREW (NOT INCLUDED)	REPLACEMENT SEAL KIT PART NUMBER (NOT INCLUDED)	SPANNER WRENCH (NOT INCLUDED)
BT 50												
BT50-TG10-DPOR-6	0.094 - 1.000	TG 100	2.500	5.25	3.150	E-7353S	100 PSI	1000 PSI	2500	116-001	585-920	112-001

(1), (2) - These are recommended pressures. Lower coolant pressures may be utilized at very slow RPM's. Pressures above recommended PSI may cause internal damage to seals.
 (3) - Recommended Maximum RPM at Maximum 1000 PSI. Higher speeds may be achieved at lower pressures.

These RPM and Pressure ranges are not a guarantee of performance. The life and performance of the units depends on the following conditions:
 Proper Filtration - Proper Type & Viscosity of Coolant - Coolant Pressure and Volume.
All units require coolant at all speeds.

AUTO TOOL CHANGE : ATC

BT END MILL HOLDERS • DUAL PIN O-RING ROTARY COOLANT GLAND

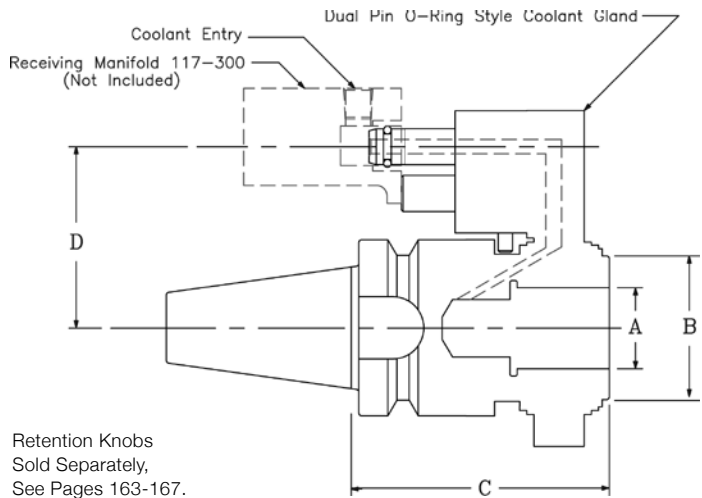

ASSEMBLY PART NUMBER	A I.D. (IN.)	B CLEARANCE DIA. (IN.)	C PROJECTION (IN.)	D CTR TO CTR (IN.)	COOLANT GLAND (INCLUDED)	MINIMUM COOLANT PRESSURE (1)	MAXIMUM COOLANT PRESSURE (2)	MAXIMUM SPEED (RPM) (3)	COOLANT STOP SCREW (INCLUDED)	REPLACEMENT SEAL KIT PART NUMBER (NOT INCLUDED)
BT 50										
BT50-EM10-DPOR-5	1.000	2.500	4.50	3.150	E-7353S	100 PSI	1000 PSI	2500	105-006	585-920
^BT50-EM12-DPOR-5	1.250	2.500	4.50	3.150	E-7353S	100 PSI	1000 PSI	2500	105-006	585-920
^BT50-EM15-DPOR-5	1.500	2.500	4.50	3.150	E-7353S	100 PSI	1000 PSI	2500	105-006	585-920

^ - Socket set screw location does not conform to ANSI specification. Request information if set screw location is critical.

(1), (2) - These are recommended pressures. Lower coolant pressures may be utilized at very slow RPM's. Pressures above recommended PSI may cause internal damage to seals.
 (3) - Recommended Maximum RPM at Maximum 1000 PSI. Higher speeds may be achieved at lower pressures.

These RPM and Pressure ranges are not a guarantee of performance. The life and performance of the units depends on the following conditions:
 Proper Filtration - Proper Type & Viscosity of Coolant - Coolant Pressure and Volume.
All units require coolant at all speeds.



BT MORSE TAPER HOLDERS • DUAL PIN O-RING ROTARY COOLANT GLAND

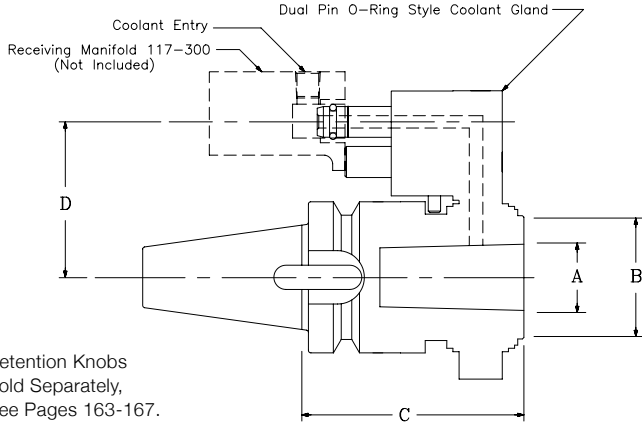

ASSEMBLY PART NUMBER	A MORSE TAPER	B CLEARANCE DIA. (IN.)	C PROJECTION (IN.)	D CTR TO CTR (IN.)	COOLANT GLAND (INCLUDED)	MINIMUM COOLANT PRESSURE (1)	MAXIMUM COOLANT PRESSURE (2)	MAXIMUM SPEED (RPM) (3)	REPLACEMENT SEAL KIT PART NUMBER (NOT INCLUDED)
BT 50									
BT50-MT3-DPOR-5	MT3	2.500	4.50	3.150	E-7353S	100 PSI	1000 PSI	2500	585-920
BT50-MT4-DPOR-5	MT4	2.500	4.50	3.150	E-7353S	100 PSI	1000 PSI	2500	585-920
BT50-MT5-DPOR-5	MT5	2.500	4.50	3.150	E-7353S	100 PSI	1000 PSI	2500	585-920

(1), (2) - These are recommended pressures. Lower coolant pressures may be utilized at very slow RPM's. Pressures above recommended PSI may cause internal damage to seals.

(3) - Recommended Maximum RPM at Maximum 1000 PSI. Higher speeds may be achieved at lower pressures.

These RPM and Pressure ranges are not a guarantee of performance. The life and performance of the units depends on the following conditions:

Proper Filtration - Proper Type & Viscosity of Coolant - Coolant Pressure and Volume.

All units require coolant at all speeds.

V-FLANGE SINGLE ANGLE COLLET CHUCK • MANUAL ROTARY COOLANT GLAND

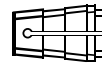
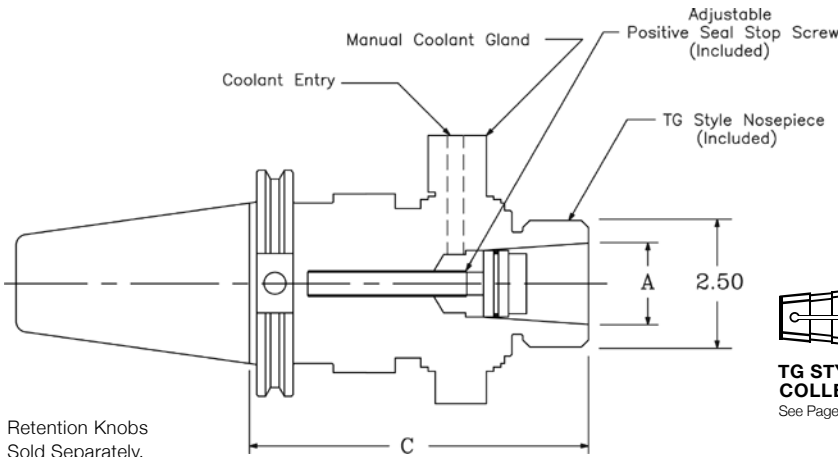

TG STYLE COLLETS
See Page 146.



•See page 111 for positive seal stop screw.

ASSEMBLY PART NUMBER	A RANGE (IN.)	COLLET SERIES	CLEARANCE DIA. (IN.)	C PROJ. (IN.)	COOLANT GLAND (INCLUDED)	MINIMUM COOLANT PRESSURE (1)	MAXIMUM COOLANT PRESSURE (2)	MAXIMUM SPEED (RPM) (3)	OPTIONAL EXTENSION STYLE STOP SCREW (NOT INCLUDED)	REPLACEMENT SEAL KIT PART NUMBER (NOT INCLUDED)	SPANNER WRENCH (NOT INCLUDED)
40 V-FLANGE											
C40-TG10-MG-6	0.094 - 1.000	TG 100	2.50	6.00	587-102	100 PSI	1000 PSI	3000	116-004	585-916	112-001
45 V-FLANGE											
*C45-TG10-MG-6	0.094 - 1.000	TG 100	2.50	6.00	587-106	100 PSI	1000 PSI	2500	116-001	585-920	112-001
50 V-FLANGE											
C50-TG10-MG-6	0.094 - 1.000	TG 100	2.50	6.00	587-106	100 PSI	1000 PSI	2500	116-001	585-920	112-001

* Outgoing Items

(1), (2) - These are recommended pressures. Lower coolant pressures may be utilized at very slow RPM's. Pressures above recommended PSI may cause internal damage to seals.

(3) - Recommended Maximum RPM at Maximum 1000 PSI. Higher speeds may be achieved at lower pressures.

These RPM and Pressure ranges are not a guarantee of performance. The life and performance of the units depends on the following conditions:

Proper Filtration - Proper Type & Viscosity of Coolant - Coolant Pressure and Volume.

All units require coolant at all speeds.



V-FLANGE DOUBLE ANGLE COLLET CHUCK • MANUAL ROTARY COOLANT GLAND

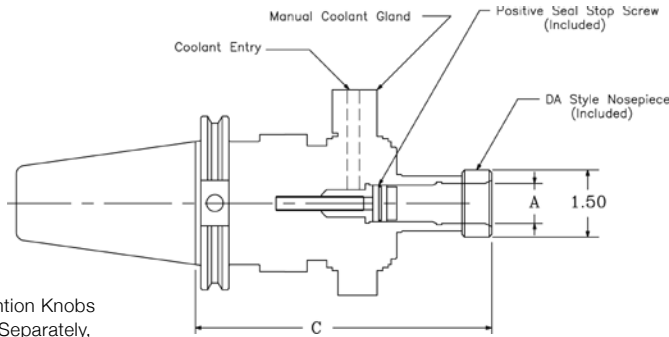

Retention Knobs
Sold Separately,
See Pages 163-167.

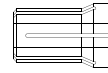

DA STYLE COLLETS
See Page 147.



• See page 111 for positive seal stop screw.

ASSEMBLY PART NUMBER	A RANGE (IN.)	COLLET SERIES	CLEARANCE DIA. (IN.)	C PROJECTION (IN.)	COOLANT GLAND (INCLUDED)	MINIMUM COOLANT PRESSURE (1)	MAXIMUM COOLANT PRESSURE (2)	MAXIMUM SPEED (RPM) (3)	REPLACEMENT SEAL KIT PART NUMBER (NOT INCLUDED)	SPANNER WRENCH (NOT INCLUDED)
40 V-FLANGE										
*C40-DA18-MG-7	0.047 - 0.750	DA 180	1.50	7.00	587-100	100 PSI	1000 PSI	4000	585-904	112-019

* Outgoing Items

(1), (2) - These are recommended pressures. Lower coolant pressures may be utilized at very slow RPM's. Pressures above recommended PSI may cause internal damage to seals.
(3) - Recommended Maximum RPM at Maximum 1000 PSI. Higher speeds may be achieved at lower pressures.

These RPM and Pressure ranges are not a guarantee of performance. The life and performance of the units depends on the following conditions:

Proper Filtration - Proper Type & Viscosity of Coolant - Coolant Pressure and Volume.

All units require coolant at all speeds.

V-FLANGE END MILL HOLDERS • MANUAL ROTARY COOLANT GLAND

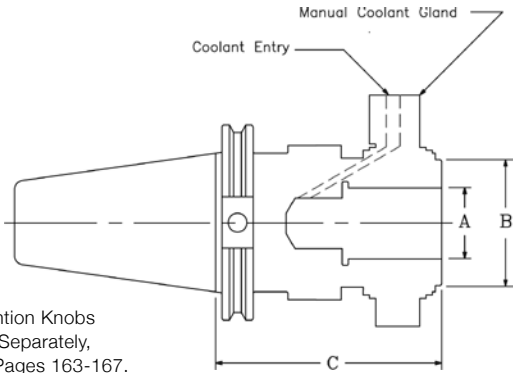

Retention Knobs
Sold Separately,
See Pages 163-167.



ASSEMBLY PART NUMBER	A I.D. (IN.)	B CLEARANCE DIA. (IN.)	C PROJECTION (IN.)	COOLANT GLAND (INCLUDED)	MINIMUM COOLANT PRESSURE (1)	MAXIMUM COOLANT PRESSURE (2)	MAXIMUM SPEED (RPM) (3)	COOLANT STOP SCREW (INCLUDED)	REPLACEMENT SEAL KIT PART NUMBER (NOT INCLUDED)
40 V-FLANGE									
C40-EM75-MG-6	0.750	1.312	5.50	587-100	100 PSI	1000 PSI	4000	NONE	585-904
C40-EM10-MG-6	1.000	1.625	5.50	587-101	100 PSI	1000 PSI	3300	NONE	585-912
^C40-EM12-MG-5	1.250	2.125	4.50	587-102	100 PSI	1000 PSI	3000	105-005	585-916
45 V-FLANGE									
*C45-EM75-MG-5	0.750	1.312	4.50	587-104	100 PSI	1000 PSI	4000	NONE	585-904
*C45-EM10-MG-5	1.000	1.625	4.50	587-105	100 PSI	1000 PSI	3300	NONE	585-912
^*C45-EM12-MG-5	1.250	2.500	4.50	587-106	100 PSI	1000 PSI	2500	105-003	585-920
^*C45-EM15-MG-5	1.500	2.500	4.50	587-106	100 PSI	1000 PSI	2500	105-003	585-920
50 V-FLANGE									
C50-EM75-MG-6	0.750	1.312	5.50	587-104	100 PSI	1000 PSI	4000	NONE	585-904
C50-EM10-MG-6	1.000	1.625	5.50	587-105	100 PSI	1000 PSI	3300	NONE	585-912
^C50-EM12-MG-5	1.250	2.500	4.50	587-106	100 PSI	1000 PSI	2500	105-004	585-920
^C50-EM15-MG-5	1.500	2.500	4.50	587-106	100 PSI	1000 PSI	2500	105-004	585-920
^C50-EM20-MG-7	2.000	3.187	6.50	587-107	100 PSI	1000 PSI	1800	105-010	585-922

* Outgoing Items

^ - Socket set screw location does not conform to ANSI specification. Request information if set screw location is critical.

(1), (2) - These are recommended pressures. Lower coolant pressures may be utilized at very slow RPM's. Pressures above recommended PSI may cause internal damage to seals.

(3) - Recommended Maximum RPM at Maximum 1000 PSI. Higher speeds may be achieved at lower pressures.

These RPM and Pressure ranges are not a guarantee of performance. The life and performance of the units depends on the following conditions:

Proper Filtration - Proper Type & Viscosity of Coolant - Coolant Pressure and Volume.

All units require coolant at all speeds.

AUTO TOOL
CHANGE : ATC



V-FLANGE ABS® STYLE HOLDERS • MANUAL ROTARY COOLANT GLAND

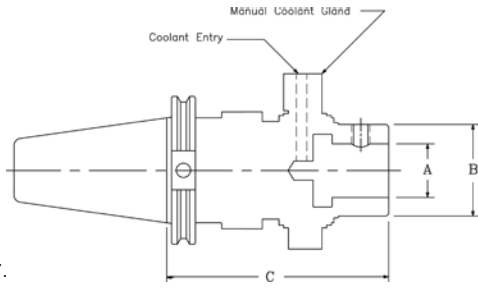

Retention Knobs
Sold Separately,
See Pages 163-167.

ASSEMBLY PART NUMBER	A ABS® CONNECTION	B CLEARANCE DIA. (IN.)	C PROJECTION (IN.)	COOLANT GLAND (INCLUDED)	MINIMUM COOLANT PRESSURE (1)	MAXIMUM COOLANT PRESSURE (2)	MAXIMUM SPEED (RPM) (3)	REPLACEMENT SEAL KIT PART NUMBER (NOT INCLUDED)
40 V-FLANGE								
C40-ABS40-MG-6	ABS 40	1.625	5.25	587-101	100 PSI	1000 PSI	3300	585-912
C40-ABS50-MG-6	ABS 50	2.125	5.50	587-102	100 PSI	1000 PSI	3000	585-916
45 V-FLANGE								
*C45-ABS40-MG-6	ABS 40	1.625	5.25	587-105	100 PSI	1000 PSI	3300	585-912
*C45-ABS50-MG-6	ABS 50	2.125	5.50	587-103	100 PSI	1000 PSI	3000	585-916
*C45-ABS63-MG-6	ABS 63	2.500	5.62	587-106	100 PSI	1000 PSI	2500	585-920
50 V-FLANGE ^								
C50-ABS40-MG-6	ABS 40	1.625	5.25	587-105	100 PSI	1000 PSI	3300	585-912
C50-ABS50-MG-6	ABS 50	2.125	5.50	587-103	100 PSI	1000 PSI	3000	585-916
C50-ABS63-MG-5	ABS 63	2.500	5.75	587-106	100 PSI	1000 PSI	2500	585-920

*** Outgoing Items** ^ - ABS 80 & ABS 100 holders available by special quotation on 50 V-Flange units.

ABS® is a registered trademark of KOMET.

• Please refer to the Modular Tooling Section on pages 140-143 for Modular Adapters

(1), (2) - These are recommended pressures. Lower coolant pressures may be utilized at very slow RPM's. Pressures above recommended PSI may cause internal damage to seals.

(3) - Recommended Maximum RPM at Maximum 1000 PSI. Higher speeds may be achieved at lower pressures.

These RPM and Pressure ranges are not a guarantee of performance. The life and performance of the units depends on the following conditions:

Proper Filtration - Proper Type & Viscosity of Coolant - Coolant Pressure and Volume.

All units require coolant at all speeds.

V-FLANGE MORSE TAPER HOLDERS • MANUAL ROTARY COOLANT GLAND

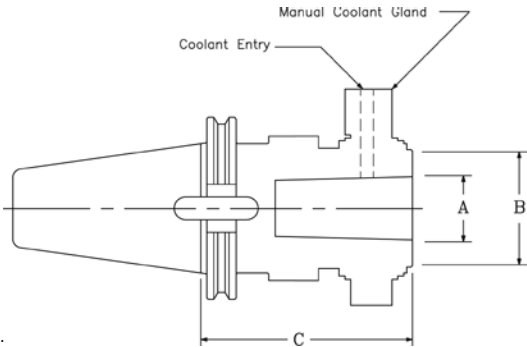

Retention Knobs
Sold Separately,
See Pages 163-167.

ASSEMBLY PART NUMBER	A MORSE TAPER	B CLEARANCE DIA. (IN.)	C PROJECTION (IN.)	COOLANT GLAND (INCLUDED)	MINIMUM COOLANT PRESSURE (1)	MAXIMUM COOLANT PRESSURE (2)	MAXIMUM SPEED (RPM) (3)	REPLACEMENT SEAL KIT PART NUMBER (NOT INCLUDED)
40 V-FLANGE								
C40-MT3-MG-5	MT3	2.125	4.50	587-102	100 PSI	1000 PSI	3000	585-916
C40-MT3-MG-5A	MT3	1.312	4.50	587-100	100 PSI	1000 PSI	4000	585-904
C40-MT4-MG-5	MT4	2.125	4.50	587-102	100 PSI	1000 PSI	3000	585-916
C40-MT4-MG-5A	MT4	1.312	4.50	587-100	100 PSI	1000 PSI	4000	585-904
45 V-FLANGE								
*C45-MT3-MG-5	MT3	2.500	4.50	587-106	100 PSI	1000 PSI	2500	585-920
*C45-MT3-MG-5A	MT3	1.312	4.50	587-104	100 PSI	1000 PSI	4000	585-904
*C45-MT4-MG-5	MT4	2.500	4.50	587-106	100 PSI	1000 PSI	2500	585-920
*C45-MT4-MG-5A	MT4	1.312	4.50	587-104	100 PSI	1000 PSI	4000	585-904
50 V-FLANGE								
C50-MT3-MG-5	MT3	2.500	4.50	587-106	100 PSI	1000 PSI	2500	585-920
C50-MT3-MG-5A	MT3	1.312	4.50	587-104	100 PSI	1000 PSI	4000	585-904
C50-MT4-MG-5	MT4	2.500	4.50	587-106	100 PSI	1000 PSI	2500	585-920
C50-MT4-MG-5A	MT4	1.312	4.50	587-104	100 PSI	1000 PSI	4000	585-904
C50-MT5-MG-5	MT5	2.500	4.50	587-106	100 PSI	1000 PSI	2500	585-920

*** Outgoing Items**

(1), (2) - These are recommended pressures. Lower coolant pressures may be utilized at very slow RPM's. Pressures above recommended PSI may cause internal damage to seals.

(3) - Recommended Maximum RPM at Maximum 1000 PSI. Higher speeds may be achieved at lower pressures.

These RPM and Pressure ranges are not a guarantee of performance. The life and performance of the units depends on the following conditions:

Proper Filtration - Proper Type & Viscosity of Coolant - Coolant Pressure and Volume.

All units require coolant at all speeds.



BT SINGLE ANGLE COLLET CHUCK • MANUAL ROTARY COOLANT GLAND

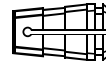
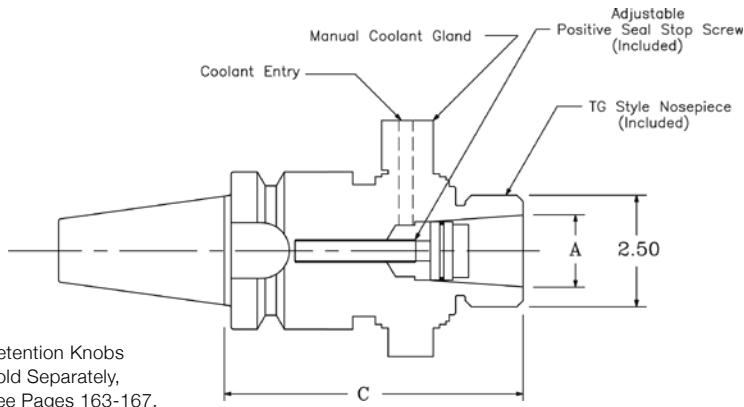

TG STYLE COLLETS
See Page 146.



•See page 111 for positive seal stop screw.

ASSEMBLY PART NUMBER	A RANGE (IN.)	COLLET SERIES	CLEARANCE DIA. (IN.)	C PROJ. (IN.)	COOLANT GLAND (INCLUDED)	MINIMUM COOLANT PRESSURE (1)	MAXIMUM COOLANT PRESSURE (2)	MAXIMUM SPEED (RPM) (3)	OPTIONAL EXTENSION STYLE STOP SCREW (NOT INCLUDED)	REPLACEMENT SEAL KIT PART NUMBER (NOT INCLUDED)	SPANNER WRENCH (NOT INCLUDED)
BT 40											
BT40-TG10-MG-6	0.094 - 1.000	TG 100	2.50	5.25	587-102	100 PSI	1000 PSI	3000	116-004	585-916	112-001
BT 50											
BT50-TG10-MG-6	0.094 - 1.000	TG 100	2.50	5.25	587-106	100 PSI	1000 PSI	2500	116-001	585-920	112-001

(1), (2) - These are recommended pressures. Lower coolant pressures may be utilized at very slow RPM's. Pressures above recommended PSI may cause internal damage to seals.

(3) - Recommended Maximum RPM at Maximum 1000 PSI. Higher speeds may be achieved at pressures below 1000 PSI.

These RPM and Pressure ranges are not a guarantee of performance. The life and performance of the units depends on the following conditions:

Proper Filtration - Proper Type & Viscosity of Coolant - Coolant Pressure and Volume.

All units require coolant at all speeds.

AUTO TOOL CHANGE : ATC

BT END MILL HOLDERS • MANUAL ROTARY COOLANT GLAND

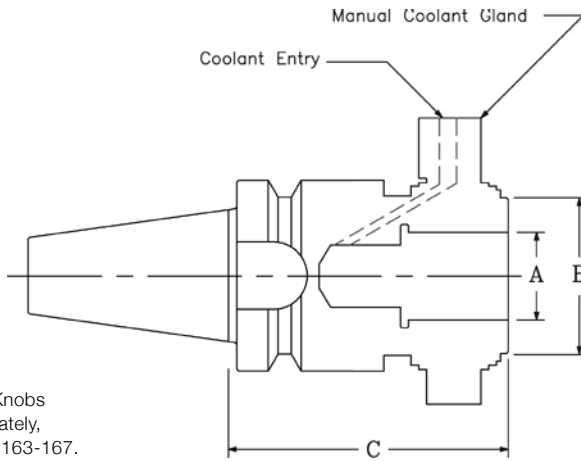

ASSEMBLY PART NUMBER	A I.D. (IN.)	B CLEARANCE DIA. (IN.)	C PROJ. (IN.)	COOLANT GLAND (INCLUDED)	MINIMUM COOLANT PRESSURE (1)	MAXIMUM COOLANT PRESSURE (2)	MAXIMUM SPEED (RPM) (3)	COOLANT STOP SCREW (INCLUDED)	REPLACEMENT SEAL KIT PART NUMBER (NOT INCLUDED)
BT 40									
BT40-EM75-MG-6	0.750	1.312	5.50	587-100	100 PSI	1000 PSI	4000	105-007	585-904
BT40-EM10-MG-5	1.000	2.125	4.50	587-102	100 PSI	1000 PSI	3000	105-007	585-916
^BT40-EM12-MG-5	1.250	2.125	4.50	587-102	100 PSI	1000 PSI	3000	105-007	585-916
BT 50									
BT50-EM10-MG-5	1.000	2.500	4.50	587-106	100 PSI	1000 PSI	2500	105-006	585-920
^BT50-EM12-MG-5	1.250	2.500	4.50	587-106	100 PSI	1000 PSI	2500	105-006	585-920
^BT50-EM15-MG-5	1.500	2.500	4.50	587-106	100 PSI	1000 PSI	2500	105-006	585-920

^ - Socket set screw location does not conform to ANSI specification. Request information if set screw location is critical.

(1), (2) - These are recommended pressures. Lower coolant pressures may be utilized at very slow RPM's. Pressures above recommended PSI may cause internal damage to seals.

(3) - Recommended Maximum RPM at Maximum 1000 PSI. Higher speeds may be achieved at pressures below 1000 PSI.

These RPM and Pressure ranges are not a guarantee of performance. The life and performance of the units depends on the following conditions:

Proper Filtration - Proper Type & Viscosity of Coolant - Coolant Pressure and Volume.

All units require coolant at all speeds.



BT MORSE TAPER HOLDERS • MANUAL ROTARY COOLANT GLAND

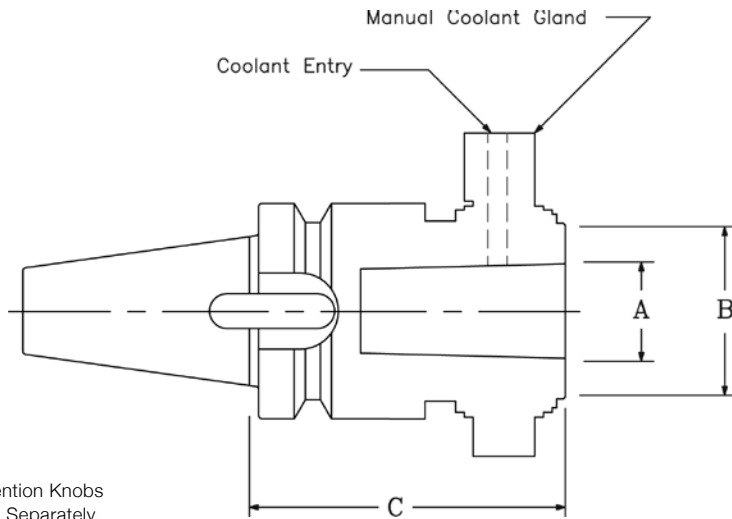

Retention Knobs
Sold Separately,
See Pages 163-167.

ASSEMBLY PART NUMBER	A MORSE TAPER	B CLEARANCE DIA. (IN.)	C PROJECTION (IN.)	COOLANT GLAND (INCLUDED)	MINIMUM COOLANT PRESSURE (1)	MAXIMUM COOLANT PRESSURE (2)	MAXIMUM SPEED (RPM) (3)	REPLACEMENT SEAL KIT PART NUMBER (NOT INCLUDED)
BT 40								
BT40-MT2-MG-5	MT2	2.125	4.50	587-102	100 PSI	1000 PSI	3000	585-916
BT40-MT3-MG-5	MT3	2.125	4.50	587-102	100 PSI	1000 PSI	3000	585-916
BT40-MT4-MG-5	MT4	2.125	4.50	587-102	100 PSI	1000 PSI	3000	585-916
BT 50								
BT50-MT3-MG-5	MT3	2.500	4.50	587-106	100 PSI	1000 PSI	2500	585-920
BT50-MT4-MG-5	MT4	2.500	4.50	587-106	100 PSI	1000 PSI	2500	585-920
BT50-MT5-MG-5	MT5	2.500	4.50	587-106	100 PSI	1000 PSI	2500	585-920

(1), (2) - These are recommended pressures. Lower coolant pressures may be utilized at very slow RPM's. Pressures above recommended PSI may cause internal damage to seals.
(3) - Recommended Maximum RPM at Maximum 1000 PSI. Higher speeds may be achieved at pressures below 1000 PSI.

These RPM and Pressure ranges are not a guarantee of performance. The life and performance of the units depends on the following conditions:
Proper Filtration - Proper Type & Viscosity of Coolant - Coolant Pressure and Volume.
All units require coolant at all speeds.



ATC GLAND SPECIFICATIONS AND REPAIR PARTS

ATC GLAND PART NUMBER	BEARING DIAMETER (IN.)	MAXIMUM SPEED (RMP)	MINIMUM PRESSURE (PSI)	MAXIMUM PRESSURE (PSI)	SEAL KIT PART NUMBER
SPFS-STYLE					
AI-0189T (45/50V)	1.625	3300	100	1000	585-912
AI-0189Y (45/50V)	1.312	4000	100	1000	585-904
AI-9789V (40V)	1.312	4000	100	1000	585-904
AI-9789T (40V)	1.625	3300	100	1000	585-912
AI-9889N (40V)	2.125	3000	100	1000	585-916
AI-9989S (45/50V)	2.500	2500	100	1000	585-920
AI-9989X (45/50V)	2.125	3300	100	1000	585-916
AR-0689Z (45/50V)	3.187	1800	100	1000	585-922
SPOR-STYLE					
V7419B (40V)	1.312	4000	100	1000	585-904
V7419J (40V)	1.625	3300	100	1000	585-912
V7419M (40V)	2.125	3000	100	1000	585-916
DPOR-STYLE					
E7353B (45/50V)	1.312	4000	100	1000	585-904
E7353D (45/50V)	1.625	3300	100	1000	585-912
E7353X (45/50V)	2.125	3000	100	1000	585-916
E7353S (45/50V)	2.500	2500	100	1000	585-920
MANUAL-STYLE					
587-100 (40V)	1.312	4000	100	1000	585-904
587-101 (40V)	1.625	3300	100	1000	585-912
587-102 (40V)	2.125	3000	100	1000	585-916
587-103 (45/50V)	2.125	3000	100	1000	585-916
587-104 (45/50V)	1.312	4000	100	1000	585-904
587-105 (45/50V)	1.625	3300	100	1000	585-912
587-106 (45/50V)	2.500	2500	100	1000	585-920
587-107 (45/50V)	3.187	1800	100	1000	585-922

AUTO TOOL CHANGE : ATC

FACE SEAL REPAIR KIT FOR SPFS-STYLE GLANDS

Kit includes (24) Face seal washers and Two-part Epoxy Adhesive: Order 100-001.

SPOR-STYLE GLANDS - SPARE O-RING FOR PIN

Order 001-039

DPOR-STYLE GLANDS - SPARE O-RING FOR PIN

Order 001-038

We offer Repair and Reconditioning services for our ATC glands. Please call us at **1.800.600.2248** for an RGA Number to return the unit to us. We will inspect the unit and forward a quote for the repair to you promptly!



SPECIAL APPLICATION ROTARY COOLANT GLAND ASSEMBLY QUESTIONNAIRE

For a custom adaptation to suit your machining center, please fill out this questionnaire & fax to **(1-216-481-9966)** or email to **sales@coolantfedtooling.com**.

We will respond promptly to your request for quotation.

COMPANY _____		
ADDRESS _____		
PHONE _____	FAX _____	CONTACT _____
INDICATE YOUR GEORGE WHALLEY DISTRIBUTOR OR CONTACT _____		

<p>MACHINE SPECIFICATIONS :</p> <p>1. All possible data, including manufacturer's name, model name, model number, serial number and whether vertical or horizontal? _____</p> <p>2. Machine horsepower? _____</p>	<p>SPINDLE</p> <p>1. What is the maximum R.P.M. of the machine spindle? _____</p> <p>2. What is the R.P.M. requirement for the tool being used in this application? _____</p> <p>3. What is the inside taper (bore) of the spindle (i.e. 30, 35, 40, 45, 50, 60 V-Flange or BT, etc.) _____</p> <p>4. What is the bolt circle diameter on the face of the spindle? _____</p> <p>5. What is the thread size and spacing of the bolts in the spindle bolt circle? _____</p>
<p>MACHINE LIMITATIONS</p> <p>1. For purposes of positioning the tool holder and coolant gland in proper relation to the machine spindle, advise what means of orientation is used? A. Drive key _____ B. Drive slot _____ C. Other _____</p> <p>2. What is the weight limitation of the holder? A. With the cutting tool _____ B. Without the cutting tool _____</p> <p>3. What is the maximum length clearance of the holder? _____ A. With the cutting tool _____ B. Without the cutting tool _____</p> <p>4. What is the centerline distance on the tool carousel for maximum tool diameter? _____</p>	<p>HOLDER</p> <p>1. What types of cutting tools will be used? (Indicate shank specifications for each.) _____</p> <p>2. Specify type of holder required: A. End Mill (Bore size) _____ B. Collet Chuck (Capacity) _____ C. Morse Taper _____ D. Other _____</p>

POSITIVE SEAL ADJUSTMENT STOP SCREWS

IMPORTANT! COLLET CHUCK USERS PLEASE READ

The introduction of The George Whalley Company's positive seal adjustment stop screws provides a solution to a major problem in coolant-fed machining operations. Coolant-fed cutting tools are able to deliver coolant to the cutting edge to assist cooling and chip ejection but this advantage can be seriously reduced when leakage at the stop screw decreases the coolant flow and pressure. The various standard adjustment stop screws generally in use in the machining industry for adjusting cutting tool length have basic disadvantages when used with coolant-fed tools. Steel stop screws have no sealing capability and are of little use in coolant-fed operations. Industry standard nylon capped steel stop screws provide a coolant seal where the tool shank meets the nylon cap but considerable leakage and loss of coolant pressure occurs around the screw threads. Solid nylon stop screws can provide a solution to this problem however they tend to be subject to wear when frequent tool adjustments are required. The George Whalley Company can provide all of the proceeding stop screws to interchange with industry standard holders. We strongly recommend our exclusive positive seal stop screw which will eliminate leakage and will handle necessary pressures to allow peak performance to the cutting tool. The George Whalley Company's positive seal adjustment stop screw also has the advantage of using fine screw threads for finer tool length adjustment. The illustrations and text which follow explain their use and capability.



STANDARD POSITIVE SEAL ADJUSTMENT STOP SCREWS

These stop screws are designed exclusively for use with The George Whalley Company's positive seal style collet chucks. For information on which collet chucks accept these stop screws please see tool holders section of catalog.

1. Coolant is delivered through the coolant gland pipe thread orifice in rotary inducer style holders or coolant passage through the axis of stop screw in coolant-thru-the-spindle holders.
2. Rotary inducer style holders have seals at the gland bearing surface to prevent coolant leakage.
3. Coolant enters the tool holder chamber where an O-ring seal prevents coolant loss around the outside diameter of stop screw head. A coolant cross hole in the neck of the stop screw then admits coolant for delivery to the cutting tool.
4. At the location where the cutting tool shank end meets the stop screw face, a nylon cap prevents leakage.
5. The nylon extension meets the end of the cutting tool shank, inside the single angle collet, for tool length adjustment and to seal against coolant leakage.
6. Coolant flows out through the cutting tool at maximum available pressure for cooling and chip ejection.

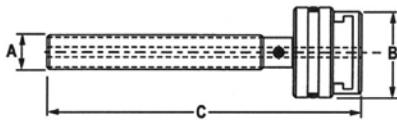
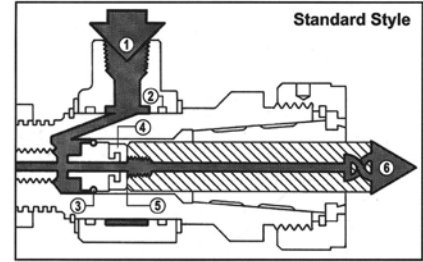

PART NUMBER	OLD PART NO.	(A) THREAD SIZE	B	C
104-001	851-001P	1/2-20 LH	1.135	3.750
104-002	851-002P	7/16-20 LH	0.825	3.750
104-003	851-003P	7/16-20 LH	1.135	3.750
104-004	851-004P	7/16-20 LH	1.135	2.250
104-005	851-005P	7/16-20 LH	1.135	2.750
104-006	851-006P	5/8-18 LH	1.665	1.750
104-007	851-007P	5/8-18 LH	1.665	3.375
104-008	851-008P	5/8-18 LH	1.665	2.250
104-009	851-009P	7/16-20 LH	0.825	2.250

EXTENSION STYLE POSITIVE SEAL ADJUSTMENT STOP SCREWS

These stop screws are designed to prevent coolant leakage between the stop screw face and the shank of short shanked cutting tools. An extension is projected into the bore of the collet for sealing and tool length adjustment. For use in collet chucks which use TG10 and TG15 series single angle collets.

1. Coolant is delivered through the coolant gland pipe thread orifice in rotary inducer style holders or coolant passage through the axis of stop screw in coolant-thru-the-spindle holders.
2. Rotary inducer style holders have seals at the gland bearing surface to prevent coolant leakage.
3. Coolant enters the tool holder chamber where an O-ring seal prevents coolant loss around the outside diameter of stop screw head. A coolant cross hole in the neck of the stop screw then admits coolant for delivery to the cutting tool.
4. Nylon cap is mounted to the positive seal stop screw to accept nylon extensions. These nylon extensions are manufactured slightly undersize to provide clearance for insertion into the rear end of the single angle collet without interfering with collet grip. Where the nylon extension is inserted in the nylon cap, an O-ring is provided to prevent leakage.
5. The nylon extension meets the end of the cutting tool shank, inside the single angle collet, for tool length adjustment and to seal against coolant leakage.
6. Coolant flows out through the cutting tool at maximum available pressure for cooling and chip ejection.

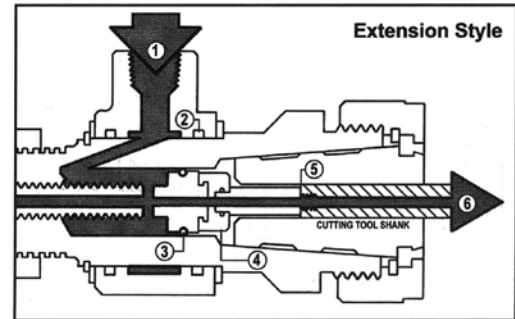

AUTO TOOL CHANGE : ATC

EXTENSION STYLE STOP SCREW SETS

Each extension stop screw set listed includes **one extension stop screw** and one each of the **seven extensions** listed below.

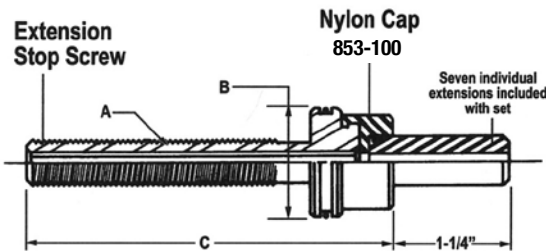

PART NUMBER	OLD PART NUMBER	(A) THREAD SIZE	B APPROX.	C APPROX.
116-001	851-011P	1/2-20 LH	1.135	3.75
116-002	851-013P	7/16-20 LH	1.135	3.75
116-003	851-014P	7/16-20 LH	1.135	2.25
116-004	851-015P	7/16-20 LH	1.135	2.75

EXTENSION STYLE POSITIVE SEAL STOP SCREWS

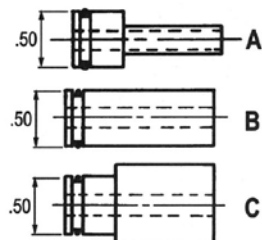

STYLE	PART NUMBER	OLD PART NUMBER	DIA.
A	106-001	853-010	0.250
A	106-002	853-012	0.312
A	106-003	853-014	0.375
A	106-004	853-016	0.437
B	106-005	853-018	0.500
C	106-006	853-020	0.620
C	106-007	853-022	0.750



Rotary Coolant Collars are designed in three styles -Standard RPM (CGS), High RPM (CGH) and 2 Piece High RPM (CGH2) for manual and transfer type machines. Specifically designed for applications where space is at a minimum.

Rotary Coolant Collars are used in many special applications. If you have a special requirement, please call your local Representative or our factory.

ROTARY COOLANT COLLARS • STANDARD RPM

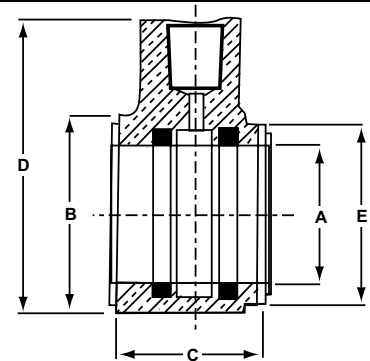
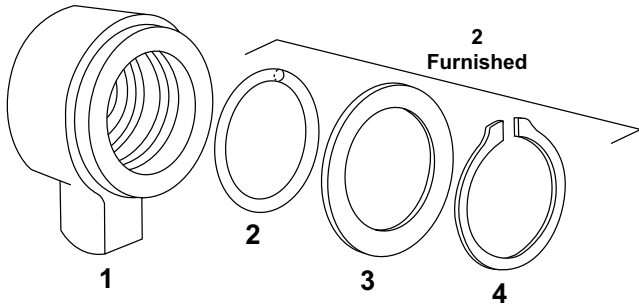

ASSEMBLY PART NUMBER	A I.D. (IN.)	B O.D. (IN.)	C WIDTH (IN.)	D OAL (IN.)	E SHIELD I.D. (IN.)	MINIMUM COOLANT PRESSURE (1)	MAXIMUM COOLANT PRESSURE (2)	MAXIMUM SPEED (RPM) (3)	O-RING PART NUMBER (2 PCS INCLUDED)	THRUST WASHER (2 PCS INCLUDED)	SNAP RING (2 PCS INCLUDED)
CGS-0937	0.937	1.375	1.250	2.250	1.375	100 PSI	750 PSI	1300	001-001	403-001	001-201
CGS-1250	1.250	1.750	1.250	2.750	1.625	100 PSI	750 PSI	1100	001-002	403-002	001-202
CGS-1625	1.625	2.375	1.500	3.125	2.187	100 PSI	750 PSI	1000	001-003	403-003	001-204
CGS-2250	2.250	3.000	1.625	3.875	2.875	100 PSI	750 PSI	600	001-004	403-004	001-205
CGS-2750	2.750	4.000	1.562	4.875	3.937	100 PSI	750 PSI	500	001-005	403-005	001-206

(1), (2) - These are recommended pressures. Lower coolant pressures may be utilized at very slow RPM's. Pressures above recommended PSI may cause internal damage to O-Rings.

(3) - Recommended Maximum RPM at Maximum 750 PSI. Higher speeds may be achieved at lower pressures.

These RPM and Pressure ranges are not a guarantee of performance. The life and performance of the units depends on the following conditions:

Proper Filtration - Proper Type & Viscosity of Coolant - Coolant Pressure and Volume.

All units require coolant at all speeds. Oil Mist may be utilized with these units at very low RPM.

ROTARY COOLANT COLLARS • HIGH RPM

General Operating Recommendations For All Rotary Coolant Collars See Page 114.

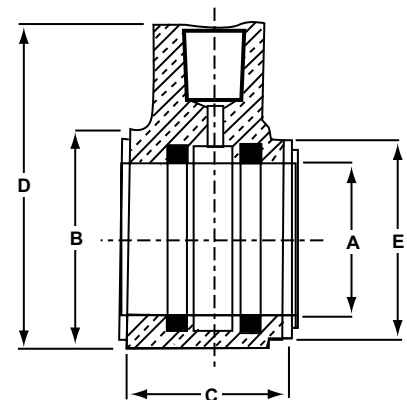
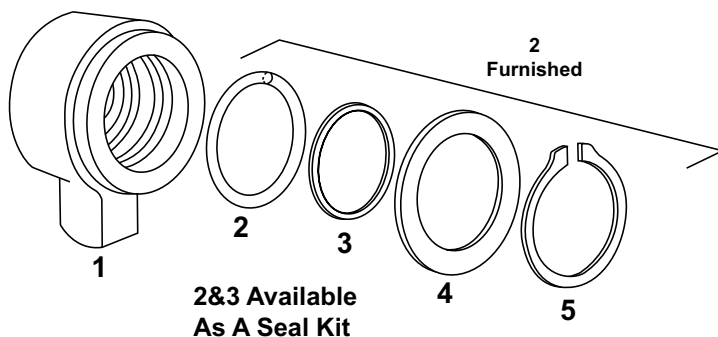

ASSEMBLY PART NUMBER	A I.D. (IN.)	B O.D. (IN.)	C WIDTH (IN.)	D OAL (IN.)	E SHIELD I.D. (IN.)	MINIMUM COOLANT PRESSURE (1)	MAXIMUM COOLANT PRESSURE (2)	MAXIMUM SPEED (RPM) (3)	THRUST WASHER (2 PCS INCLUDED)	SNAP RING (2 PCS INCLUDED)	REPLACEMENT SEAL KIT PART NUMBER (NOT INCLUDED)
CGH-0937	0.937	1.375	1.250	2.250	1.375	100 PSI	750 PSI	5000	403-001	001-201	SK-0937
CGH-1250	1.250	1.750	1.250	2.750	1.625	100 PSI	750 PSI	4000	403-002	001-202	SK-1250
CGH-1500	1.500	2.312	1.500	3.125	2.187	100 PSI	750 PSI	3600	403-013	001-203	SK-1500
CGH-1625	1.625	2.312	1.500	3.125	2.187	100 PSI	750 PSI	3300	403-003	001-204	SK-1625
CGH-2250	2.250	3.000	1.625	3.875	2.875	100 PSI	750 PSI	2800	403-004	001-205	SK-2250
CGH-2750	2.750	4.000	1.562	4.875	3.937	100 PSI	750 PSI	2200	403-005	001-206	SK-2750
CGH-3500	2.750	5.500	1.562	5.500	-	100 PSI	1000 PSI	1500	403-006	001-207	SK-3500
CGH-4000	2.750	6.000	1.750	6.000	-	100 PSI	1000 PSI	1400	866-027	001-208	SK-4000

(1), (2) - These are recommended pressures. Lower coolant pressures may be utilized at very slow RPM's. Pressures above recommended PSI may cause internal damage to seals.

(3) - Recommended Maximum RPM at Maximum 750/1000 PSI. Higher speeds may be achieved at pressures below 1000 PSI.

These RPM and Pressure ranges are not a guarantee of performance. The life and performance of the units depends on the following conditions:

Proper Filtration - Proper Type & Viscosity of Coolant - Coolant Pressure and Volume.

All units require coolant at all speeds.



ROTARY COOLANT COLLARS - 2 PIECE HIGH RPM

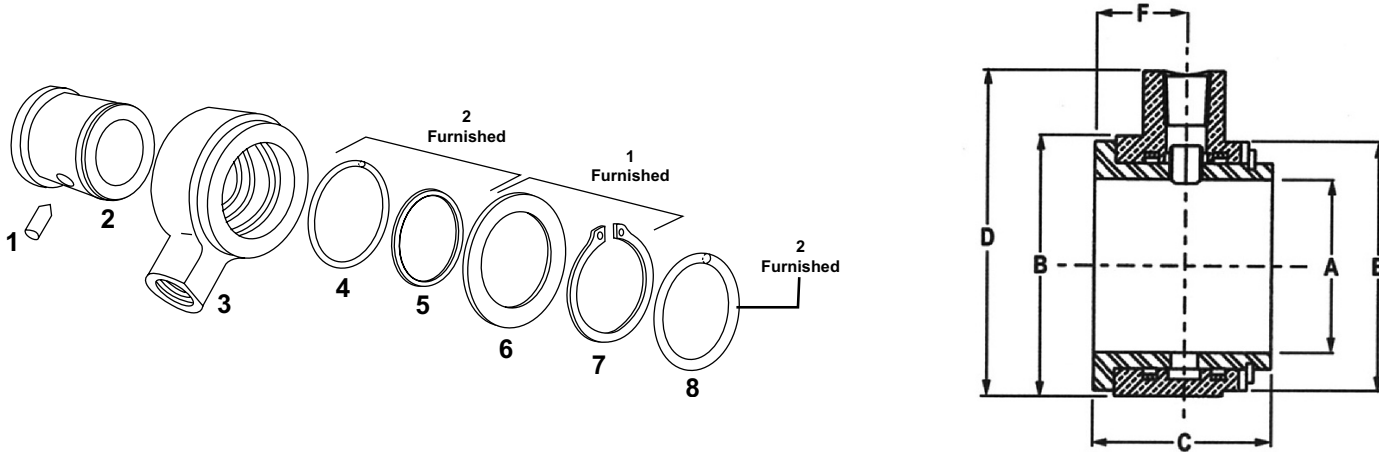

Dimensions

ASSEMBLY PART NUMBER	OLD PART NUMBER	A I.D. (IN.)	B O.D. (IN.)	C WIDTH (IN.)	D OAL (IN.)	E SHIELD I.D. (IN.)	F CTR (IN.)	MINIMUM COOLANT PRESSURE (1)	MAXIMUM COOLANT PRESSURE (2)	MAXIMUM SPEED (RPM) (3)	THRUST WASHER (2 PCS INCLUDED)	SNAP RING (2 PCS INCLUDED)	MATING SHANK O-RING (2 PCS INCLUDED)	REPLACEMENT SEAL KIT PART NUMBER (NOT INCLUDED)
CGH2-1250	801-081	1.250	2.187	1.594	3.125	2.187	0.8750	100 PSI	750 PSI	4000	403-007	001-204	001-006	SK2-1250
CGH2-1500	801-082	1.500	2.187	1.812	3.125	2.187	0.9687	100 PSI	750 PSI	3600	103-008	001-208	001-007	SK2-1500
CGH2-2000	801-083	2.000	3.000	2.062	3.812	2.875	1.0000	100 PSI	750 PSI	3100	103-009	001-209	001-021	SK2-2000
CGH2-2000A	801-090	2.000	3.000	1.875	3.750	-	0.8750	100 PSI	750 PSI	3100	403-009	001-209	001-021	SK2-2000
CGH2-2500	801-091	2.500	4.000	1.938	4.750	-	0.9375	100 PSI	750 PSI	2500	403-010	001-210	001-022	SK2-2500
CGH2-2562	801-084	2.562	4.062	2.312	5.000	3.312	1.1250	100 PSI	750 PSI	2200	403-014	001-215	001-022	SK2-2562
CGH2-4250	801-085	4.250	6.000	3.000	7.125	-	1.5000	100 PSI	1000 PSI	1100	866-875	001-216	001-027	SK2-4250

(1), (2) - These are recommended pressures. Lower coolant pressures may be utilized at very slow RPM's. Pressures above recommended PSI may cause internal damage to seals.

(3) - Recommended Maximum RPM at Maximum 750 PSI. Higher speeds may be achieved at lower pressures.

These RPM and Pressure ranges are not a guarantee of performance. The life and performance of the units depends on the following conditions:

Proper Filtration - Proper Type & Viscosity of Coolant - Coolant Pressure and Volume.

All units require coolant at all speeds.

ROTARY COOLANT TOOL HOLDERS

PLASTIC SPLASH SHIELD ASSEMBLIES

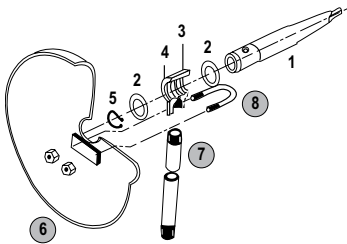

STANDARD RPM COOLANT GLAND	HIGH RPM COOLANT GLAND	(6) PLASTIC SHIELD 9-5/8 OD X 1-1/2 LG	SHIELD INSIDE DIAMETER	(7) COOLANT TORQUE BAR 3/8-18 NPT X 11"	(8) U-BOLT ASSEMBLY
CGS-0937	CGH-0937	846-001	1-3/8	869-001TB	874-001UB
CGS-1250	CGH-1250	846-002	1-5/8	869-001TB	874-001UB
CGS-1625	CGH-1500	846-003	2-3/16	869-001TB	874-001UB
CGS-2250	CGH-2250	846-004	2-7/8	869-001TB	874-001UB
CGS-2750	CGH-2750	846-005	3-15/16	869-001TB	874-001UB

ASSEMBLY & PARTS DIAGRAM FOR STANDARD ROTARY COOLANT GLAND

1. Tool holder shank
2. Thrust washers (2)
3. Coolant inducer rings -apply grease or bearing lubricant
4. O-rings (2) -apply grease or bearing lubricant
5. Snap ring
6. Shield Assembly
7. 3/8 D.E. Pipe Nipple
8. U-bolt & washer assembly*

CAUTION: (1) All holders with coolant glands (rotary coolant inducers) must have torque arm (pipe nipple) secured to prevent coolant hose interference with machine operation. **(2)** Rotary coolant assemblies are not designed to operate without coolant. **(3)** Torque arm centerline to be perpendicular to spindle centerline to maximize seal life.



SHANK MOUNTING SPECIFICATIONS FOR THE GEORGE WHALLEY CO. STANDARD AND HIGH RPM ONE-PIECE ROTARY COOLANT GLANDS

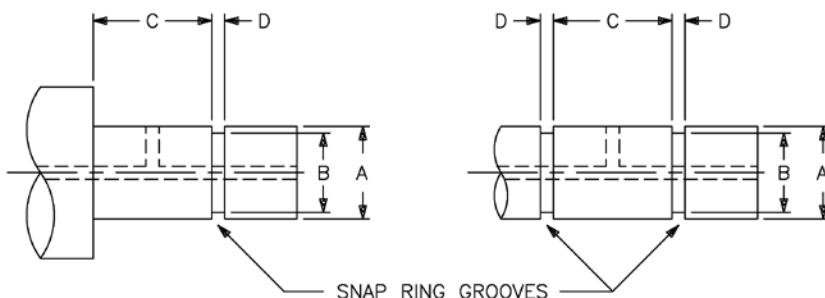

A SHANK O.D.	B SNAP RING GROOVE O.D.	C GLAND BEARING WIDTH	D SNAP RING WIDTH	FOR USE WITH COOLANT GLAND NUMBER
0.9360/0.9340	0.8790/0.8850	1.380/1.385	0.046/0.048	CGH/CGS - 0937
1.249/1.247	1.172/1.180	1.380/1.385	0.056/0.060	CGH/CGS - 1250
1.624/1.622	1.524/1.534	1.630/1.635	0.068/0.072	CGH/CGS - 1625
2.249/2.247	2.114/2.126	1.815/1.820	0.086/0.091	CGH/CGS - 2250
2.749/2.747	2.596/2.608	1.755/1.760	0.103/0.108	CGH/CGS - 2750
3.499/3.497	3.310/3.322	1.815/1.820	0.103/0.108	CGH - 3500
3.999/3.997	3.786/3.798	2.002/2.006	0.120/0.125	CGH - 4000

SHANK MOUNTING SPECIFICATIONS FOR THE GEORGE WHALLEY CO. HIGH RPM TWO-PIECE ROTARY COOLANT GLANDS

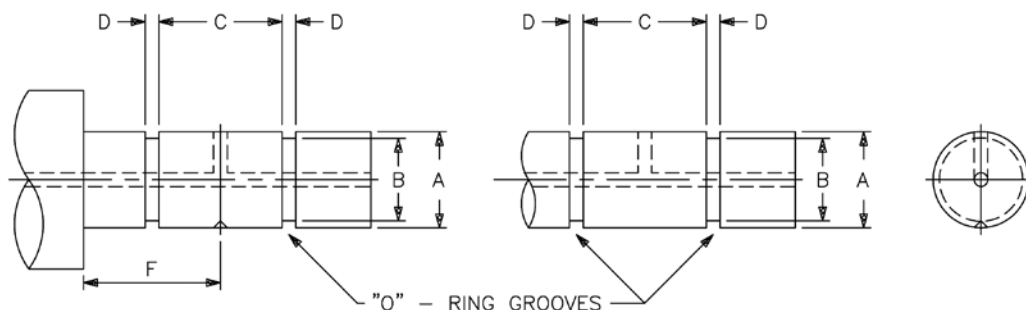

A SHANK O.D.	B O-RING GROOVE O.D.	C GLAND BEARING WIDTH	D O-RING WIDTH	F SET SCREW POINT LOCATION	FOR USE WITH COOLANT GLAND NUMBER
1.249/1.247	1.135	1.000	0.090/0.094	0.906	CGH2 - 0937
1.499/1.497	1.380	1.000	0.090/0.094	1.000	CGH2 - 1250
1.999/1.997	1.885	1.250	0.090/0.094	1.063	CGH2 - 1625
2.561/2.559	2.375	1.500	0.138/0.142	1.188	CGH2 - 2250
4.249/4.247	4.025	1.500	0.175/0.185	1.531	CGH2 - 2750
1.999/1.997	1.885	1.250	0.090/0.094	0.906	801 - 083A
2.449/2.497	2.390	1.500	0.090/0.094	0.969	801 - 091

BREAK IN AND OPERATING RECOMMENDATIONS FOR AUTOMATIC AND MANUAL TOOL CHANGE COOLANT GLANDS

In order to assure proper lubrication, even wear, and proper seating, high RPM glands should be broken in at 100 RPM for 3 minutes with coolant introduced at a pressure and volume between 100 PSI and 500 PSI to prevent overloading seals. Repeat procedure at 500 RPM for 3 minutes, and again at 1000 RPM. After break in procedure is complete, units may be run at pressures between 100 PSI and 750/1000 PSI.

For maximum life and performance of these coolant glands and seals the following conditions are recommended:

1. Coolant filtration: 30 to 50 micron minimum; 5 micron optimum
2. Proper type & viscosity of coolant: preferably a good water soluble synthetic with good lubrication and heat dissipation under pressure.
3. Coolant pressure: minimum of 100 lbs. coolant pressure at high R.P.M's (1800 SFM or more based on I.D. dimension of coolant gland or O.D. bearing diameter of tool holder). Maximum pressure of 750/1000 PSI.
4. Coolant volume must be sufficient to properly lubricate cutting tool as recommended by its manufacturer. The combination of volume and pressure can not exceed the coolant orifice delivery capability of your tool or premature gland failure may result due to excessive heat build up.



V-FLANGE SINGLE ANGLE COLLET CHUCKS WITH POSITIVE SEAL ADJUSTING STOP SCREW AND ROTARY COOLANT COLLARS

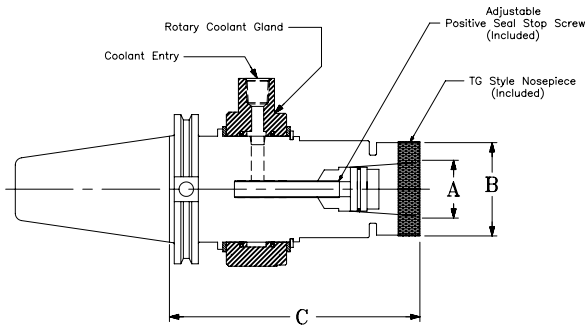

TG Style Collets
See page 146.

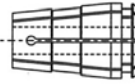

• See page 111 for positive seal stop screw.

ASSEMBLY PART NUMBER	A RANGE (IN.)	COLLET SERIES	B CLEARANCE (IN.)	C PROJ. (IN.)	COOLANT GLAND (INCLUDED)	MINIMUM COOLANT PRESSURE (1)	MAXIMUM COOLANT PRESSURE (2)	MAXIMUM SPEED (RPM) (3)	REPLACEMENT SEAL KIT PART NUMBER (NOT INCLUDED)	OPTIONAL EXTENSION STYLE STOP SCREW (NOT INCLUDED)	SPANNER WRENCH (NOT INCLUDED)
50 V-FLANGE											
C50-TG10-CGH-7P	0.094 - 1.000	TG 100	2.50	7.00	CGH-2250	100 PSI	750 PSI	2800	SK-2250	116-001	112-001
C50-TG15-CGH-8P	0.500 - 1.500	TG 150	3.50	8.00	CGH-2750	100 PSI	750 PSI	2200	SK-2750	-	112-002

• See pages 112-114 for Rotary Coolant Collars information.

(1), (2) - These are recommended pressures. Lower coolant pressures may be utilized at very slow RPM's. Pressures above recommended PSI may cause internal damage to seals.
(3) - Recommended Maximum RPM at Maximum 750 PSI. Higher speeds may be achieved at lower pressures.

These RPM and Pressure ranges are not a guarantee of performance. The life and performance of the units depends on the following conditions:

Proper Filtration - Proper Type & Viscosity of Coolant - Coolant Pressure and Volume.

All units require coolant at all speeds.

V-FLANGE END MILL HOLDERS WITH HIGH RPM ROTARY COOLANT GLANDS

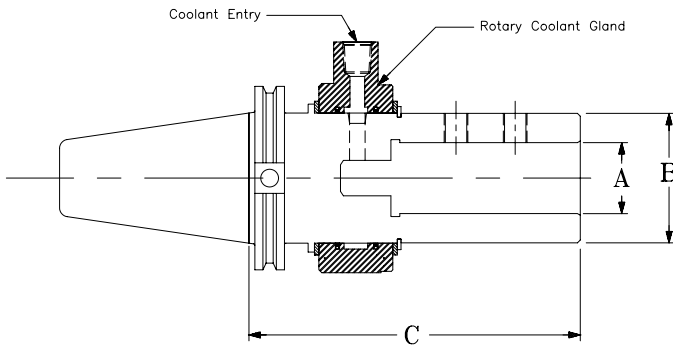

Retention Knobs
Sold Separately,
See Pages 163-167.



ROTARY COOLANT
TOOL HOLDERS

ASSEMBLY PART NUMBER	A I.D. (IN.)	B CLEARANCE (IN.)	C PROJECTION (IN.)	COOLANT GLAND (INCLUDED)	MINIMUM COOLANT PRESSURE (1)	MAXIMUM COOLANT PRESSURE (2)	MAXIMUM SPEED (RPM) (3)	REPLACEMENT SEAL KIT PART NUMBER (NOT INCLUDED)
50 V-FLANGE								
C50-EM12-CGH-7	1.250	2.75	7.00	CGH-2750	100 PSI	750 PSI	2200	SK-2750
C50-EM15-CGH-7	1.500	2.75	7.00	CGH-2750	100 PSI	750 PSI	2200	SK-2750
C50-EM17-CGH-7	1.750	3.50	7.00	CGH-3500	100 PSI	1000 PSI	1500	SK-3500
C50-EM20-CGH-7	2.000	3.50	7.00	CGH-3500	100 PSI	1000 PSI	1500	SK-3500
C50-EM22-CGH-7	2.250	4.00	7.00	CGH-4000	100 PSI	1000 PSI	1400	SK-4000

(1), (2) - These are recommended pressures. Lower coolant pressures may be utilized at very slow RPM's. Pressures above recommended PSI may cause internal damage to seals.
(3) - Recommended Maximum RPM at Maximum 750/1000 PSI. Higher speeds may be achieved at lower pressures.

These RPM and Pressure ranges are not a guarantee of performance. The life and performance of the units depends on the following conditions:

Proper Filtration - Proper Type & Viscosity of Coolant - Coolant Pressure and Volume.

All units require coolant at all speeds.

• See pages 112-114 for Rotary Coolant Gland information

• For CAT 40 End Mill Holders please see bottom of page 105.
(Manual ATC End Mill Holders)



V-FLANGE MORSE TAPER HOLDERS WITH HIGH RPM ROTARY COOLANT GLAND

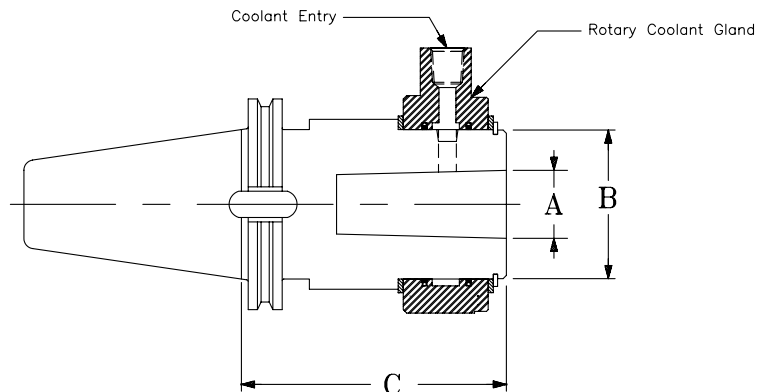

With High RPM Rotary Coolant Glands

ASSEMBLY PART NUMBER	A MORSE TAPER	B CLEARANCE (INCHES)	C PROJECTION (INCHES)	COOLANT GLAND (INCLUDED)	MINIMUM COOLANT PRESSURE (1)	MAXIMUM COOLANT PRESSURE (2)	MAXIMUM SPEED (RPM) (3)	REPLACEMENT SEAL KIT PART NUMBER (NOT INCLUDED)
45 V-FLANGE								
*C45-MT4-CGH-4	MT 4	1.62	3.18	CGH-1625	100 PSI	750 PSI	3300	SK-1625
50 V-FLANGE								
*C50-MT4-CGH-4	MT 4	1.62	3.38	CGH-1625	100 PSI	750 PSI	3300	SK-1625
*C50-MT5-CGH-5	MT 5	2.75	4.25	CGH-2750	100 PSI	750 PSI	2200	SK-2750

* Outgoing Items

- See pages 112-114 for Rotary Coolant Gland information.

(1), (2) - These are recommended pressures. Lower coolant pressures may be utilized at very slow RPM's. Pressures above recommended PSI may cause internal damage to seals.

(3) - Recommended Maximum RPM at Maximum 750 PSI. Higher speeds may be achieved at lower pressures.

These RPM and Pressure ranges are not a guarantee of performance. The life and performance of the units depends on the following conditions:

Proper Filtration - Proper Type & Viscosity of Coolant - Coolant Pressure and Volume.

All units require coolant at all speeds.

NMTB TAPER SHANK • SINGLE ANGLE COLLET CHUCKS WITH POSITIVE SEAL ADJUSTING STOP SCREW AND ROTARY COOLANT GLAND

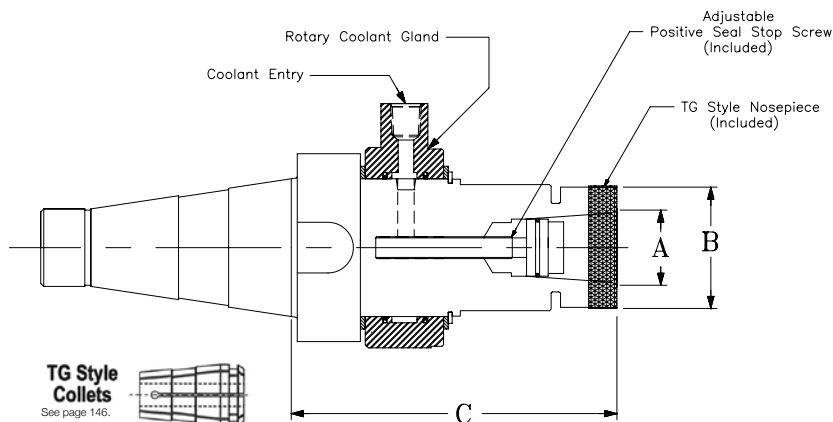

- See page 111 for positive seal stop screw.

ASSEMBLY PART NUMBER	A RANGE (IN.)	COLLET SERIES	B CLEARANCE (IN.)	C PROJ. (IN.)	COOLANT GLAND (INCLUDED)	MINIMUM COOLANT PRESSURE (1)	MAXIMUM COOLANT PRESSURE (2)	MAXIMUM SPEED (RPM) (3)	REPLACEMENT SEAL KIT PART NUMBER (NOT INCLUDED)	OPTIONAL EXTENSION STYLE STOP SCREW (NOT INCLUDED)	SPANNER WRENCH (NOT INCLUDED)
40 NMTB											
N40-TG10P-7	0.094 - 1.000	TG 100	2.50	6.25	CGH-2250	100 PSI	750 PSI	2800	SK-2250	116-002	112-001
N40-TG15P-7	0.500 - 1.500	TG 150	3.50	6.25	CGH-2750	100 PSI	750 PSI	2200	SK-2750	-	112-002
50 NMTB											
N50-TG10P-7	0.094 - 1.000	TG 100	2.50	6.25	CGH-2250	100 PSI	750 PSI	2800	SK-2250	116-002	112-001
N50-TG15P-7	0.500 - 1.500	TG 150	3.50	6.25	CGH-2750	100 PSI	750 PSI	2200	SK-2750	-	112-002

- See pages 112-114 for Rotary Coolant Gland information.

(1), (2) - These are recommended pressures. Lower coolant pressures may be utilized at very slow RPM's. Pressures above recommended PSI may cause internal damage to seals.

(3) - Recommended Maximum RPM at Maximum 750 PSI. Higher speeds may be achieved at lower pressures.

These RPM and Pressure ranges are not a guarantee of performance. The life and performance of the units depends on the following conditions:

Proper Filtration - Proper Type & Viscosity of Coolant - Coolant Pressure and Volume.

All units require coolant at all speeds.



NMTB TAPER SHANK • END MILL HOLDERS WITH ROTARY COOLANT GLAND

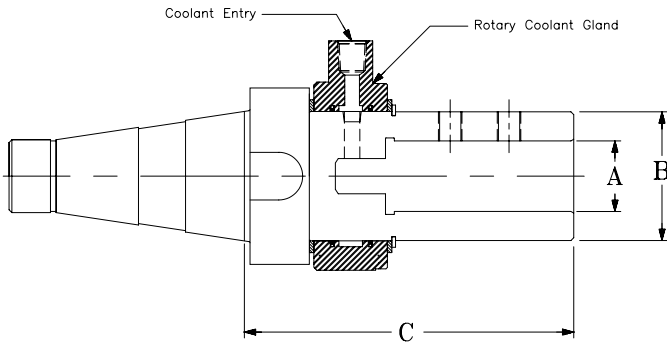

ASSEMBLY PART NUMBER	A I.D. (IN.)	B CLEARANCE (IN.)	C PROJECTION (IN.)	COOLANT GLAND (INCLUDED)	MINIMUM COOLANT PRESSURE (1)	MAXIMUM COOLANT PRESSURE (2)	MAXIMUM SPEED (RPM) (3)	REPLACEMENT SEAL KIT PART NUMBER (NOT INCLUDED)
30 NMTB								
*N30-EM75-4	0.750	2.25	3.88	CGH-1625	100 PSI	750 PSI	3300	SK-1625
40 NMTB								
N40-EM10-4	1.000	2.25	3.88	CGH-2250	100 PSI	750 PSI	2800	SK-2250
50 NMTB								
N50-EM75-5	0.750	2.25	4.75	CGH-2250	100 PSI	750 PSI	2800	SK-2250
N50-EM12-7	1.250	2.75	7.00	CGH-2750	100 PSI	750 PSI	2200	SK-2750
N50-EM15-7	1.500	2.75	7.00	CGH-2750	100 PSI	750 PSI	2200	SK-2750
N50-EM17-7	1.750	3.50	7.00	CGH-3500	100 PSI	1000 PSI	1500	SK-3500
N50-EM20-7	2.000	3.50	7.00	CGH-3500	100 PSI	1000 PSI	1500	SK-3500
N50-EM22-7	2.250	4.75	7.00	CGH-4000	100 PSI	1000 PSI	1400	SK-4000
N50-EM25-7	2.500	4.75	7.00	CGH-4000	100 PSI	1000 PSI	1400	SK-4000
N50-EM30-10	3.000	4.75	9.00	CGH-4000	100 PSI	1000 PSI	1400	SK-4000

* Outgoing Items

• NMTB End Mill Holders are supplied with set screws. • See pages 112-114 for Rotary Coolant Gland information.

(1), (2) - These are recommended pressures. Lower coolant pressures may be utilized at very slow RPM's. Pressures above recommended PSI may cause internal damage to seals.

(3) - Recommended Maximum RPM at Maximum 750/1000 PSI. Higher speeds may be achieved at lower pressures.

These RPM and Pressure ranges are not a guarantee of performance. The life and performance of the units depends on the following conditions:

Proper Filtration - Proper Type & Viscosity of Coolant - Coolant Pressure and Volume.

All units require coolant at all speeds.

ROTARY COOLANT TOOL HOLDERS

NMTB TAPER SHANK • MORSE TAPER HOLDERS WITH HIGH RPM ROTARY COOLANT GLAND

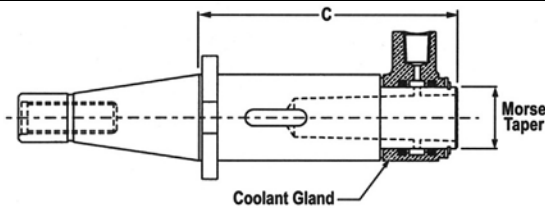

ASSEMBLY PART NUMBER	A MORSE TAPER	C PROJECTION (IN.)	COOLANT GLAND (INCLUDED)	MINIMUM COOLANT PRESSURE (1)	MAXIMUM COOLANT PRESSURE (2)	MAXIMUM SPEED (RPM) (3)	REPLACEMENT SEAL KIT PART NUMBER (NOT INCLUDED)
40 NMTB							
*N40-MT2-CGH-4	MT 2	4.00	CGH-0937	100 PSI	750 PSI	5000	SK-0937
*N40-MT3-CGH-4	MT 3	4.87	CGH-1250	100 PSI	750 PSI	4000	SK-1250
50 NMTB							
*N50-MT3-CGH-5	MT 3	5.38	CGH-1250	100 PSI	750 PSI	4000	SK-1250
*N50-MT4-CGH-3	MT 4	3.12	CGH-1625	100 PSI	750 PSI	3300	SK-1625
*N50-MT5-CGH-3	MT 5	3.50	CGH-2250	100 PSI	750 PSI	2800	SK-2250
*N50-MT5-CGH-7	MT 5	7.25	CGH-2250	100 PSI	750 PSI	2800	SK-2250

* Outgoing Items

• See pages 112-114 for Rotary Coolant Gland information.

(1), (2) - These are recommended pressures. Lower coolant pressures may be utilized at very slow RPM's. Pressures above recommended PSI may cause internal damage to seals.

(3) - Recommended Maximum RPM at Maximum 750 PSI. Higher speeds may be achieved at lower pressures.

These RPM and Pressure ranges are not a guarantee of performance. The life and performance of the units depends on the following conditions:

Proper Filtration - Proper Type & Viscosity of Coolant - Coolant Pressure and Volume.

All units require coolant at all speeds.



STRAIGHT SHANK • MORSE TAPER HOLDERS WITH ROTARY COOLANT GLAND

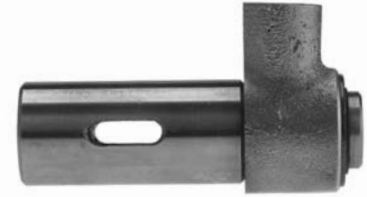
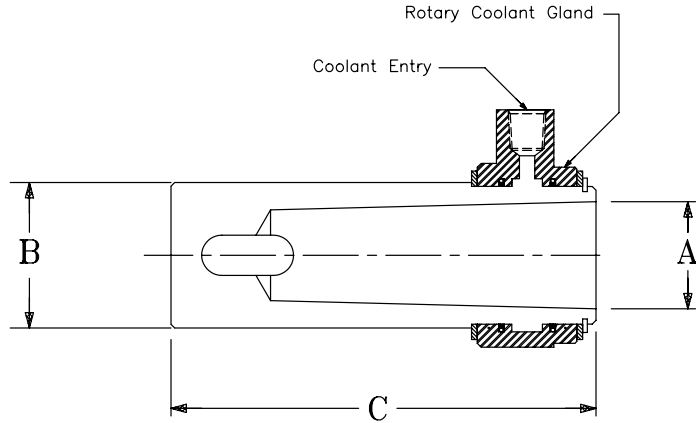

ASSEMBLY PART NUMBER	A MORSE TAPER	B SHANK DIA. (IN.)	C OAL (IN.)	COOLANT GLAND (INCLUDED)	MINIMUM COOLANT PRESSURE (1)	MAXIMUM COOLANT PRESSURE (2)	MAXIMUM SPEED (RPM) (3)	REPLACEMENT SEAL KIT PART NUMBER (NOT INCLUDED)
SS12-MT2-CGH-4	MT 2	1.250	4.00	CGH-1250	100 PSI	750 PSI	4000	SK-1250
SS12-MT3-CGH-6	MT 3	1.250	5.75	CGH-1250	100 PSI	750 PSI	4000	SK-1250
SS12-MT4-CGH-6	MT 4	1.250	5.75	CGH-1625	100 PSI	750 PSI	3300	SK-1625
SS15-MT2-CGH-4	MT 3	1.500	4.00	CGH-1250	100 PSI	750 PSI	4000	SK-1250
SS15-MT3-CGH-6	MT 4	1.500	5.75	CGH-1250	100 PSI	750 PSI	4000	SK-1250

(1), (2) - These are recommended pressures. Lower coolant pressures may be utilized at very slow RPM's. Pressures above recommended PSI may cause internal damage to seals.
(3) - Recommended Maximum RPM at Maximum 750 PSI. Higher speeds may be achieved at lower pressures.

These RPM and Pressure ranges are not a guarantee of performance. The life and performance of the units depends on the following conditions:

Proper Filtration - Proper Type & Viscosity of Coolant - Coolant Pressure and Volume.

All units require coolant at all speeds.

FACE MOUNTED DOUBLE ANGLE COLLET CHUCK WITH HIGH RPM ROTARY COOLANT GLAND FOR USE WITH DRILL SPEEDER

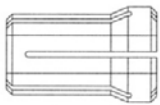

DA Style Collets

See page 147.

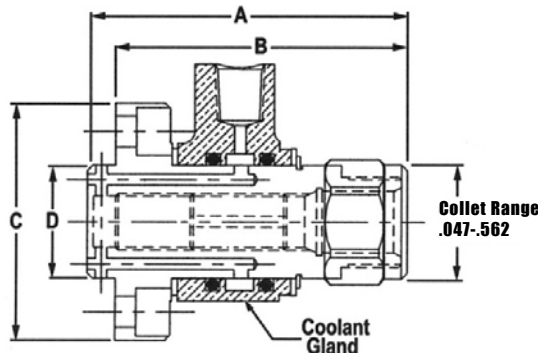

ASSEMBLY PART NUMBER	A OAL (IN.)	B PROJ. (IN.)	C DIA. (IN.)	D DIA. (IN.)	MAX. SCREW ADJUST (IN.)	COOLANT GLAND (INCLUDED)	MINIMUM COOLANT PRESSURE (1)	MAXIMUM COOLANT PRESSURE (2)	MAXIMUM SPEED (RPM) (3)	REPLACEMENT SEAL KIT PART NUMBER (NOT INCLUDED)
*FM-DA10-4	3.937	3.625	2.625	1.250	1.25	CGH-1250	100 PSI	750 PSI	4000	SK-1250

* Outgoing Items

- Holders use DA10 collets • See pages 112-114 for Rotary Coolant Gland information.
- Furnished with High RPM Coolant Gland and Nylon Seal Stop Screw

(1), (2) - These are recommended pressures. Lower coolant pressures may be utilized at very slow RPM's. Pressures above recommended PSI may cause internal damage to seals.

(3) - Recommended Maximum RPM at Maximum 750 PSI. Higher speeds may be achieved at lower pressures.

These RPM and Pressure ranges are not a guarantee of performance. The life and performance of the units depends on the following conditions:

Proper Filtration - Proper Type & Viscosity of Coolant - Coolant Pressure and Volume.

All units require coolant at all speeds.



JACOBS TAPER MOUNT • DOUBLE ANGLE COLLET CHUCKS WITH ROTARY COOLANT GLAND

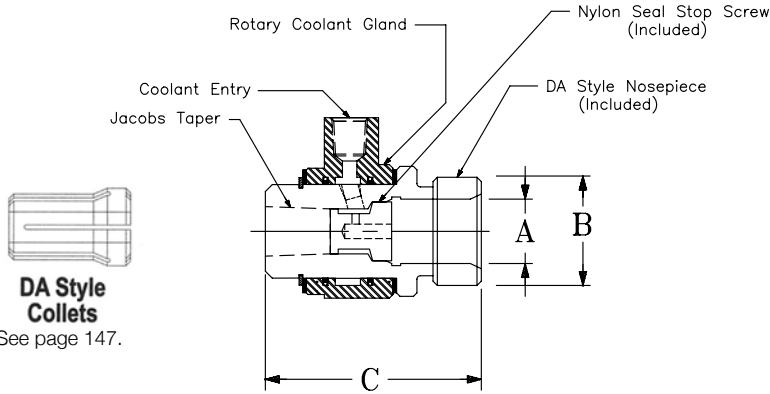

ASSEMBLY PART NUMBER	JACOBS TAPER SIZE	A RANGE (IN.)	COLLET SERIES	B CLEARANCE (IN.)	C OAL (IN.)	COOLANT GLAND (INCLUDED)	MINIMUM COOLANT PRESSURE (1)	MAXIMUM COOLANT PRESSURE (2)	MAXIMUM SPEED (RPM) (3)	NYLON SEAL STOP SCREW (INCLUDED)	REPLACEMENT SEAL KIT PART NUMBER (NOT INCLUDED)	SPANNER WRENCH (NOT INCLUDED)
JT2-DA10-CGH-2	2	0.047 - 0.562	DA 100	1.56	2.88	CGH-0937	100 PSI	750 PSI	5000	110-001	SK-0937	112-018
JT33-DA18-CGH-2	33	0.047 - 0.750	DA 180	1.62	3.53	CGH-1250	100 PSI	750 PSI	4000	110-002	SK-1250	112-019

Arbors to Adapt Jacobs Taper Collet Chucks to Machine Spindles

MACHINE SHANK	JACOBS TAPER	PART NUMBER	JACOBS TAPER	PART NUMBER	MACHINE SHANK	JACOBS TAPER	PART NUMBER	JACOBS TAPER	PART NUMBER
MORSE TAPER #1	2	831-201	33	831-301	R-8 BRIDGEPORT	2	831-207	33	831-305
MORSE TAPER #2	2	831-202	33	831-302	1/2" STRAIGHT SHANK	2	831-208	33	831-306
MORSE TAPER #3	2	831-203	33	831-303	5/8" STRAIGHT SHANK	2	831-209	33	831-307
MORSE TAPER #4	2	831-204	33	831-304	3/4" STRAIGHT SHANK	2	831-210	33	831-308
MORSE TAPER #5	2	831-205	-	-	1" STRAIGHT SHANK	2	831-211	33	831-309
BROWN & SHARPE #7	2	831-206	-	-					

• For applications where additional reach and maximum tool adjustments are needed • For replacement nylon seals, see page 158 • See pages 112-114 for Rotary Coolant Gland information.

(1), (2) - These are recommended pressures. Lower coolant pressures may be utilized at very slow RPM's. Pressures above recommended PSI may cause internal damage to seals.

(3) - Recommended Maximum RPM at Maximum 750 PSI. Higher speeds may be achieved at lower pressures.

These RPM and Pressure ranges are not a guarantee of performance. The life and performance of the units depends on the following conditions:

Proper Filtration - Proper Type & Viscosity of Coolant - Coolant Pressure and Volume.

All units require coolant at all speeds.

ROTARY COOLANT TOOLHOLDERS

STRAIGHT SHANK • END MILL HOLDERS WITH HIGH RPM ROTARY COOLANT GLAND

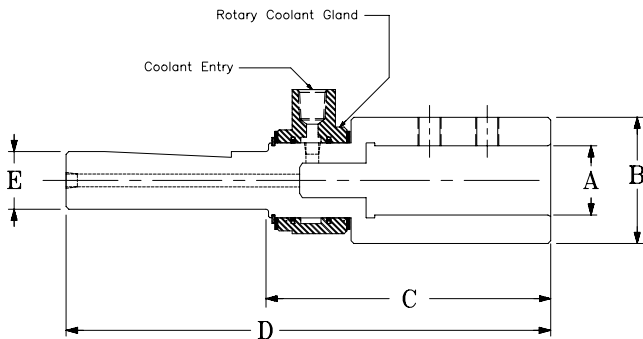

ASSEMBLY PART NUMBER	A I.D. (IN.)	B CLEARANCE (IN.)	C PROJECTION (IN.)	D OAL (IN.)	E SHANK DIA. (IN.)	COOLANT GLAND (INCLUDED)	MINIMUM COOLANT PRESSURE (1)	MAXIMUM COOLANT PRESSURE (2)	MAXIMUM SPEED (RPM) (3)	REPLACEMENT SEAL KIT PART NUMBER (NOT INCLUDED)
SS12-EM62-CGH-5	0.625	1.87	4.38	9.06	1.25	CGH-1625	100 PSI	750 PSI	3300	SK-1625
SS12-EM75-CGH-5	0.750	2.00	4.62	9.31	1.25	CGH-1625	100 PSI	750 PSI	3300	SK-1625
SS12-EM10-CGH-5	1.000	2.25	4.75	9.44	1.25	CGH-1625	100 PSI	750 PSI	3300	SK-1625
SS12-EM12-CGH-6	1.250	2.50	5.13	9.81	1.25	CGH-1625	100 PSI	750 PSI	3300	SK-1625
SS12-EM15-CGH-6	1.500	2.75	5.13	9.81	1.25	CGH-1625	100 PSI	750 PSI	3300	SK-1625

• To be used in most Straight Shank tooling applications - Gun Drills, Carbide Indexable Drills, Spade Drills, etc. • Triple entry design - (1) with coolant gland, (2) without coolant gland, (3) coolant-thru-the-spindle and stationary tool applications, thru entry on side of gland bearing surface • See pages 112-114 for Rotary Coolant Gland information.

(1), (2) - These are recommended pressures. Lower coolant pressures may be utilized at very slow RPM's. Pressures above recommended PSI may cause internal damage to seals.

(3) - Recommended Maximum RPM at Maximum 750 PSI. Higher speeds may be achieved at lower pressures.

These RPM and Pressure ranges are not a guarantee of performance. The life and performance of the units depends on the following conditions:

Proper Filtration - Proper Type & Viscosity of Coolant - Coolant Pressure and Volume.

All units require coolant at all speeds.



STRAIGHT SHANK • SINGLE ANGLE COLLET CHUCKS WITH ROTARY COOLANT GLAND AND POSITIVE STOP SCREW

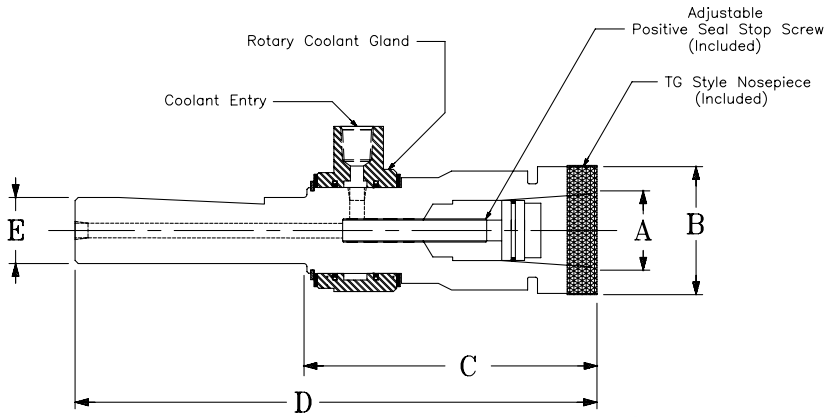

TG Style Collets
See page 146.

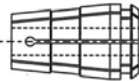

• See page 111 for positive seal stop screw.

ASSEMBLY PART NUMBER	A RANGE (IN.)	COLLET SERIES	B CLEARANCE (IN.)	C PROJ. (IN.)	D OAL (IN.)	E SHANK DIA. (IN.)	COOLANT GLAND (INCLUDED)	MINIMUM COOLANT PRESSURE (1)	MAXIMUM COOLANT PRESSURE (2)	MAXIMUM SPEED (RPM) (3)	REPLACEMENT SEAL KIT PART NUMBER (NOT INCLUDED)	OPTIONAL EXTENSION STYLE STOP SCREW (NOT INCLUDED)	SPANNER WRENCH (NOT INCLUDED)
SS12-TG10-CGH-10	0.094 - 1.000	TG 100	2.50	4.81	9.50	1.25	CGH-1625	100 PSI	750 PSI	3300	SK-1625	116-002	112-001
SS15-TG10-CGH-10	0.094 - 1.000	TG 100	2.50	4.81	9.50	1.50	CGH-1625	100 PSI	750 PSI	3300	SK-1625	116-002	112-001

- Triple entry design -(1) with coolant gland, (2) without coolant gland, (3) coolant-thru-the-spindle and stationary tool applications, thru entry on side of gland bearing surface.
- See pages 112-114 for Rotary Coolant Gland information.

(1), (2) - These are recommended pressures. Lower coolant pressures may be utilized at very slow RPM's. Pressures above recommended PSI may cause internal damage to seals.
 (3) - Recommended Maximum RPM at Maximum 750 PSI. Higher speeds may be achieved at lower pressures.

These RPM and Pressure ranges are not a guarantee of performance. The life and performance of the units depends on the following conditions:

Proper Filtration - Proper Type & Viscosity of Coolant - Coolant Pressure and Volume.

All units require coolant at all speeds.

STRAIGHT SHANK / JACOBS TAPER MOUNT • DOUBLE ANGLE COLLET CHUCK WITH POSITIVE SEAL STOP SCREW AND HIGH RPM ROTARY COOLANT GLAND

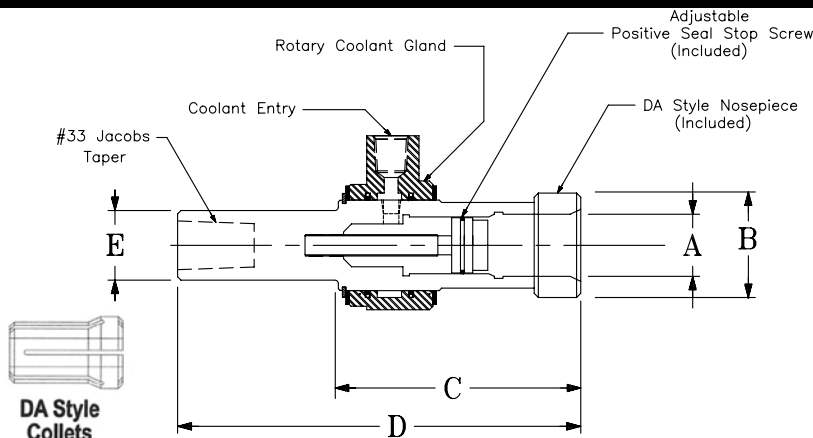

• See page 111 for positive seal stop screw.

ASSEMBLY PART NUMBER	A RANGE (IN.)	COLLET SERIES	B CLEARANCE (IN.)	C PROJ. (IN.)	D OAL (IN.)	E SHANK DIA. (IN.)	COOLANT GLAND (INCLUDED)	MINIMUM COOLANT PRESSURE (1)	MAXIMUM COOLANT PRESSURE (2)	MAXIMUM SPEED (RPM) (3)	REPLACEMENT SEAL KIT PART NUMBER (NOT INCLUDED)	SPANNER WRENCH (NOT INCLUDED)
^*SS10-JT33-DA18-CGH-4	0.047 - 0.750	DA 180	1.62	3.75	5.75	1.00	CGH-1250	100 PSI	750 PSI	4000	SK-1250	112-019

*** Outgoing Items** ^ - Shank does not conform to ANSI specifications.

- Designed to provide additional reach and maximum tool adjustment with use of our positive seal stop screw
- Single entry design requires that this chuck be used with coolant gland for coolant-thru-the-tool operations
- Maximum adjustment of stop screw is 5/8"
- See pages 112-114 for Rotary Coolant Gland information.

(1), (2) - These are recommended pressures. Lower coolant pressures may be utilized at very slow RPM's. Pressures above recommended PSI may cause internal damage to seals.
 (3) - Recommended Maximum RPM at Maximum 750 PSI. Higher speeds may be achieved at lower pressures.

These RPM and Pressure ranges are not a guarantee of performance. The life and performance of the units depends on the following conditions:

Proper Filtration - Proper Type & Viscosity of Coolant - Coolant Pressure and Volume.

All units require coolant at all speeds.



AUTOMOTIVE ADJUSTABLE SHANK • SINGLE ANGLE COLLET CHUCK HOLDERS WITH ROTARY COOLANT GLAND

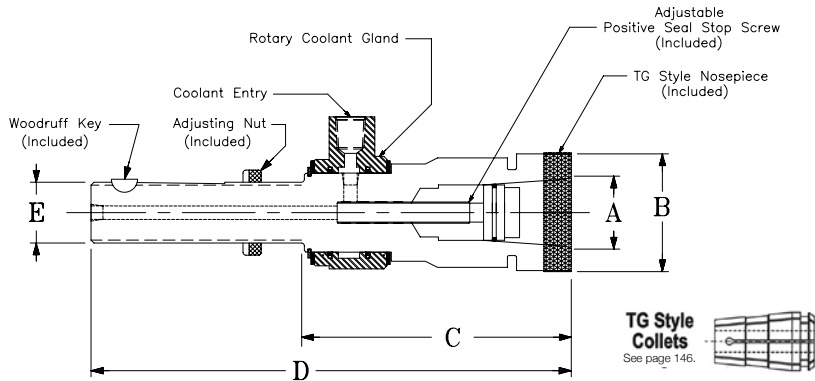

• See page 111 for positive seal stop screw.

ASSEMBLY PART NUMBER	A RANGE (IN.)	COLLET SERIES	B CLEARANCE (IN.)	C PROJ. (IN.)	D OAL (IN.)	E SHANK	COOLANT GLAND (INCLUDED)	MINIMUM COOLANT PRESSURE (1)	MAXIMUM COOLANT PRESSURE (2)	MAXIMUM SPEED (RPM) (3)	REPLACEMENT SEAL KIT PART NUMBER (NOT INCLUDED)	OPTIONAL EXTENSION STYLE STOP SCREW (NOT INCLUDED)	SPANNER WRENCH (NOT INCLUDED)
AA106-TG10-CGH-5	0.094 - 1.000	TG 100	2.50	4.62	8.25	1-1/16 - 12	CGH-1250	100 PSI	750 PSI	4000	SK-1250	-	112-001
AA137-TG10-CGH-5	0.094 - 1.000	TG 100	2.50	4.81	8.94	1-3/8 - 12	CGH-1625	100 PSI	750 PSI	3300	SK-1625	116-004	112-001
AA187-TG10-CGH-5	0.094 - 1.000	TG 100	2.50	5.00	9.87	1-7/8 - 12	CGH-1625	100 PSI	750 PSI	3300	SK-1625	116-004	112-001

• Dual Entry design allows use without gland for coolant-thru-the-spindle applications • See pages 112-114 for Rotary Coolant Gland information.

(1), (2) - These are recommended pressures. Lower coolant pressures may be utilized at very slow RPM's. Pressures above recommended PSI may cause internal damage to seals.
(3) - Recommended Maximum RPM at Maximum 750 PSI. Higher speeds may be achieved at pressures below 1000 PSI.

These RPM and Pressure ranges are not a guarantee of performance. The life and performance of the units depends on the following conditions: Proper Filtration - Proper Type & Viscosity of Coolant - Coolant Pressure and Volume.
All units require coolant at all speeds.

AUTOMOTIVE ADJUSTABLE SHANK • DOUBLE ANGLE COLLET CHUCK HOLDERS WITH ROTARY COOLANT GLAND

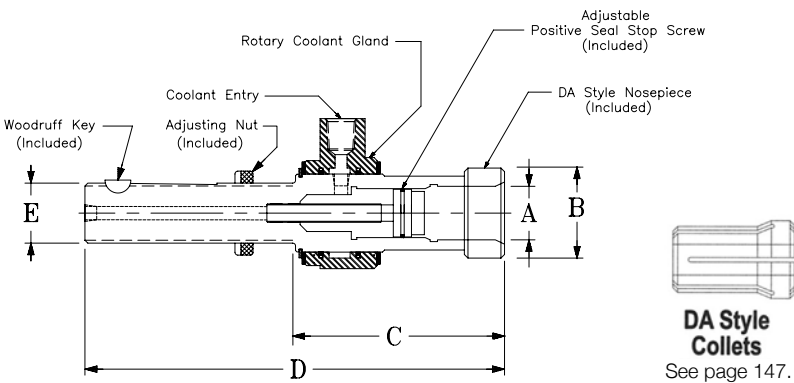

• See page 111 for positive seal stop screw.

ASSEMBLY PART NUMBER	A RANGE (IN.)	COLLET SERIES	B CLEARANCE (IN.)	C PROJ. (IN.)	D OAL (IN.)	E SHANK	COOLANT GLAND (INCLUDED)	MINIMUM COOLANT PRESSURE (1)	MAXIMUM COOLANT PRESSURE (2)	MAXIMUM SPEED (RPM) (3)	POSITIVE SEAL STOP SCREW (INCLUDED)	REPLACEMENT SEAL KIT PART NUMBER (NOT INCLUDED)	SPANNER WRENCH (NOT INCLUDED)
AA75-DA18-CGH-4	0.047 - 0.750	DA 180	1.62	3.50	7.12	3/4 - 12	CGH-1250	100 PSI	750 PSI	4000	104-009	SK-1250	112-019
AA87-DA18-CGH-4	0.047 - 0.750	DA 180	1.62	3.50	7.12	7/8 - 12	CGH-1250	100 PSI	750 PSI	4000	104-009	SK-1250	112-019
AA10-DA18-CGH-5	0.047 - 0.750	DA 180	1.62	5.31	9.03	1" - 12	CGH-1250	100 PSI	750 PSI	4000	104-002	SK-1250	112-019
AA10-DA18-CGH-4	0.047 - 0.750	DA 180	1.62	3.81	7.44	1-1/16 - 12	CGH-1250	100 PSI	750 PSI	4000	104-002	SK-1250	112-019

• Dual Entry design allows use without gland for coolant-thru-the-spindle applications • See pages 112-114 for Rotary Coolant Gland information.

(1), (2) - These are recommended pressures. Lower coolant pressures may be utilized at very slow RPM's. Pressures above recommended PSI may cause internal damage to seals.
(3) - Recommended Maximum RPM at Maximum 750 PSI. Higher speeds may be achieved at lower pressures.

These RPM and Pressure ranges are not a guarantee of performance. The life and performance of the units depends on the following conditions: Proper Filtration - Proper Type & Viscosity of Coolant - Coolant Pressure and Volume.
All units require coolant at all speeds.

ROTARY COOLANT TOOL HOLDERS



AUTOMOTIVE ADJUSTABLE SHANK • MORSE TAPER HOLDERS WITH ROTARY COOLANT GLAND

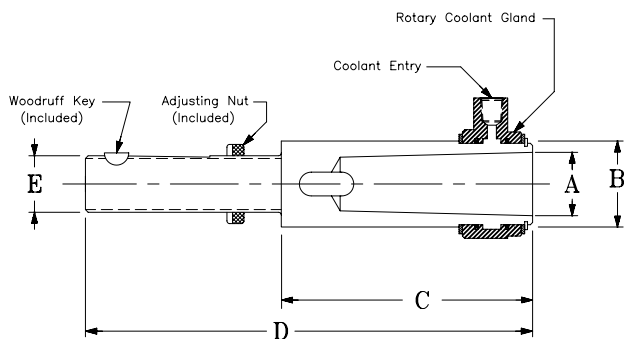

ASSEMBLY PART NUMBER	A MORSE TAPER	B CLEARANCE (IN.)	C PROJECTION (IN.)	D OAL (IN.)	E SHANK	COOLANT GLAND (INCLUDED)	MINIMUM COOLANT PRESSURE (1)	MAXIMUM COOLANT PRESSURE (2)	MAXIMUM SPEED (RPM) (3)	REPLACEMENT SEAL KIT PART NUMBER (NOT INCLUDED)
AA75-MT2-CGH-3	2	0.937	3.50	6.00	3/4 - 12	CGH-0937	100 PSI	750 PSI	5000	SK-0937
AA88-MT2-CGH-2	2	0.937	2.00	5.62	7/8 - 12	CGH-0937	100 PSI	750 PSI	5000	SK-0937
AA10-MT3-CGH-4	3	1.250	3.62	7.25	1" - 12	CGH-1250	100 PSI	750 PSI	4000	SK-1250
AA106-MT2-CGH-3	2	0.937	3.00	6.62	1-1/16 - 12	CGH-0937	100 PSI	750 PSI	5000	SK-0937
AA106-MT3-CGH-4	3	1.250	4.00	7.62	1-1/16 - 12	CGH-1250	100 PSI	750 PSI	4000	SK-1250
AA137-MT3-CGH-2	3	1.250	2.00	6.62	1-3/8 - 12	CGH-1250	100 PSI	750 PSI	4000	SK-1250
AA137-MT4-CGH-2	4	1.625	2.00	6.62	1-3/8 - 12	CGH-1625	100 PSI	750 PSI	3300	SK-1625
AA188-MT3-CGH-2	3	1.625	2.00	7.62	1-7/8 - 12	CGH-1625	100 PSI	750 PSI	3300	SK-1625
AA188-MT4-CGH-2	4	1.625	2.00	7.62	1-7/8 - 12	CGH-1625	100 PSI	750 PSI	3300	SK-1625

• See pages 112-114 for Rotary Coolant Gland information.

(1), (2) - These are recommended pressures. Lower coolant pressures may be utilized at very slow RPM's. Pressures above recommended PSI may cause internal damage to seals.

(3) - Recommended Maximum RPM at Maximum 750 PSI. Higher speeds may be achieved at lower pressures.

These RPM and Pressure ranges are not a guarantee of performance. The life and performance of the units depends on the following conditions:

Proper Filtration - Proper Type & Viscosity of Coolant - Coolant Pressure and Volume.

All units require coolant at all speeds.

MORSE TAPER SHANK • SINGLE ANGLE STYLE COLLET CHUCKS WITH NYLON CAP POSITIVE SEAL STOP SCREW AND ROTARY COOLANT GLAND

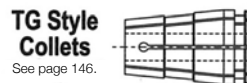
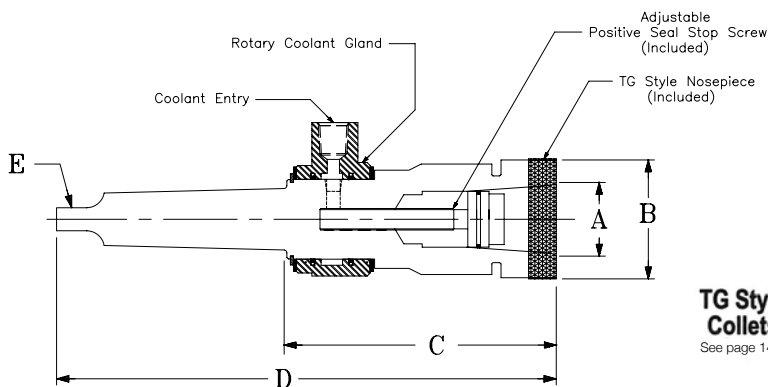

• See page 111 for positive seal stop screw.

ASSEMBLY PART NUMBER	A RANGE (IN.)	COLLET SERIES	B CLEARANCE (IN.)	C PROJ. (IN.)	D OAL (IN.)	E MORSE TAPER	COOLANT GLAND (INCLUDED)	MINIMUM COOLANT PRESSURE (1)	MAXIMUM COOLANT PRESSURE (2)	MAXIMUM SPEED (RPM) (3)	REPLACEMENT SEAL KIT PART NUMBER (NOT INCLUDED)	OPTIONAL EXTENSION STYLE STOP SCREW (NOT INCLUDED)	SPANNER WRENCH (NOT INCLUDED)
MT3-TG10-CGH-6P	0.094 - 1.000	TG 100	2.50	5.50	9.37	MT 3	CGH-1625	100 PSI	750 PSI	3300	SK-1625	116-002	112-001
MT4-TG10-CGH-6P	0.094 - 1.000	TG 100	2.50	5.50	10.37	MT 4	CGH-1625	100 PSI	750 PSI	3300	SK-1625	116-002	112-001
*MT5-TG15-CGH-7P	0.500 - 1.500	TG 150	3.50	6.25	12.37	MT 5	CGH-2750	100 PSI	750 PSI	2200	SK-2750	-	112-002
*MT6-TG15-CGH-7P	0.500 - 1.500	TG 150	3.50	6.25	14.81	MT 6	CGH-2750	100 PSI	750 PSI	2200	SK-2750	-	112-002

* Outgoing Items

• See pages 112-114 for Rotary Coolant Gland information.

(1), (2) - These are recommended pressures. Lower coolant pressures may be utilized at very slow RPM's. Pressures above recommended PSI may cause internal damage to seals.

(3) - Recommended Maximum RPM at Maximum 750 PSI. Higher speeds may be achieved at lower pressures.

These RPM and Pressure ranges are not a guarantee of performance. The life and performance of the units depends on the following conditions:

Proper Filtration - Proper Type & Viscosity of Coolant - Coolant Pressure and Volume.

All units require coolant at all speeds.



MORSE TAPER SHANK • DOUBLE ANGLE COLLET CHUCKS WITH NYLON CAP POSITIVE SEAL STOP SCREW AND ROTARY COOLANT GLAND

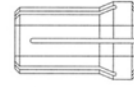
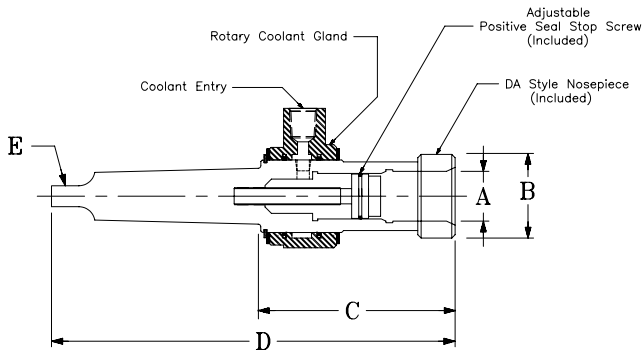

DA Style Collets
See page 147.



• See page 111 for positive seal stop screw.

ASSEMBLY PART NUMBER	A RANGE (IN.)	COLLET SERIES	B CLEARANCE (IN.)	C PROJ. (IN.)	D OAL (IN.)	E MORSE TAPER	COOLANT GLAND (INCLUDED)	MINIMUM COOLANT PRESSURE (1)	MAXIMUM COOLANT PRESSURE (2)	MAXIMUM SPEED (RPM) (3)	REPLACEMENT SEAL KIT PART NUMBER (NOT INCLUDED)	POSITIVE SEAL STOP SCREW (NOT INCLUDED)	SPANNER WRENCH (NOT INCLUDED)
*MT2-DA18-CGH-6P	0.047 - 0.750	DA 180	1.62	5.31	8.44	2	CGH-1250	100 PSI	750 PSI	4000	SK-1250	104-002	112-019
*MT3-DA18-CGH-6P	0.047 - 0.750	DA 180	1.62	5.31	9.18	3	CGH-1250	100 PSI	750 PSI	4000	SK-1250	104-002	112-019
*MT4-DA18-CGH-6P	0.047 - 0.750	DA 180	1.62	5.31	10.18	4	CGH-1250	100 PSI	750 PSI	4000	SK-1250	104-002	112-019

*** Outgoing Items**

• See pages 112-114 for Rotary Coolant Gland information.

(1), (2) - These are recommended pressures. Lower coolant pressures may be utilized at very slow RPM's. Pressures above recommended PSI may cause internal damage to seals.
(3) - Recommended Maximum RPM at Maximum 750 PSI. Higher speeds may be achieved at lower pressures.

These RPM and Pressure ranges are not a guarantee of performance. The life and performance of the units depends on the following conditions:
Proper Filtration - Proper Type & Viscosity of Coolant - Coolant Pressure and Volume.
All units require coolant at all speeds.

MORSE TAPER SHANK TO MORSE TAPER HOLDERS WITH ROTARY COOLANT GLAND

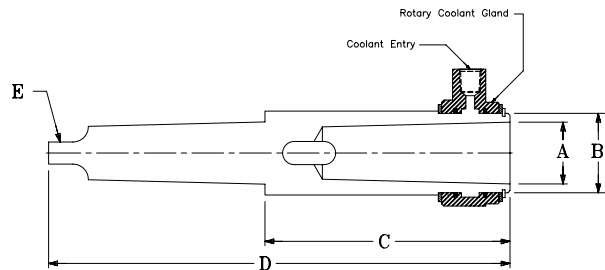

Splash Shield Assembly Included With Holder.

See page 113, for assembly instructions.



ASSEMBLY PART NUMBER *	OLD PART NUMBER	A INTERIOR TAPER	E SHANK TAPER	B CLEARANCE (IN.)	C PROJECTION (IN.)	D OAL (IN.)	COOLANT GLAND (INCLUDED)	MINIMUM COOLANT PRESSURE (1)	MAXIMUM COOLANT PRESSURE (2)	MAXIMUM SPEED (RPM) (3)	REPLACEMENT SEAL KIT PART NUMBER (NOT INCLUDED)
MT2-MT2-CGH-4	840-001	MT 2	MT 2	0.94	3.87	7.00	CGH-0937	100 PSI	750 PSI	5000	SK-0937
MT2-MT3-CGH-4	840-005	MT 2	MT 3	0.94	3.87	7.75	CGH-0937	100 PSI	750 PSI	5000	SK-0937
MT2-MT4-CGH-5	840-006	MT 2	MT 4	0.94	3.94	8.81	CGH-0937	100 PSI	750 PSI	5000	SK-0937
MT2-MT5-CGH-5	840-007	MT 2	MT 5	0.94	4.12	10.25	CGH-0937	100 PSI	750 PSI	5000	SK-0937
MT3-MT3-CGH-5	840-002	MT 3	MT 3	1.25	4.81	8.68	CGH-1250	100 PSI	750 PSI	4000	SK-1250
MT3-MT4-CGH-5	840-008	MT 3	MT 4	1.25	4.87	9.75	CGH-1250	100 PSI	750 PSI	4000	SK-1250
MT3-MT5-CGH-5	840-009	MT 3	MT 5	1.25	4.87	11.00	CGH-1250	100 PSI	750 PSI	4000	SK-1250
MT4-MT4-CGH-6	840-003	MT 4	MT 4	1.62	5.81	10.68	CGH-1625	100 PSI	750 PSI	3300	SK-1625
MT4-MT5-CGH-6	840-010	MT 4	MT 5	1.62	5.81	8.44	CGH-1625	100 PSI	750 PSI	3300	SK-1625
MT5-MT5-CGH-8	840-004	MT 5	MT 5	2.25	7.19	13.31	CGH-2250	100 PSI	750 PSI	2800	SK-2250
MT5-MT6-CGH-8	840-011	MT 5	MT 6	2.25	7.38	15.94	CGH-2250	100 PSI	750 PSI	2800	SK-2250

* - Standard RPM Coolant Glands also available. Substitute "CGS" for "CGH" in Assembly Part Numbers listed above.

(1), (2) - These are recommended pressures. Lower coolant pressures may be utilized at very slow RPM's. Pressures above recommended PSI may cause internal damage to seals.

(3) - Recommended Maximum RPM at Maximum 750 PSI. Higher speeds may be achieved at lower pressures.

These RPM and Pressure ranges are not a guarantee of performance. The life and performance of the units depends on the following conditions:
Proper Filtration - Proper Type & Viscosity of Coolant - Coolant Pressure and Volume.
All units require coolant at all speeds.



V-FLANGE SINGLE ANGLE COLLET CHUCKS

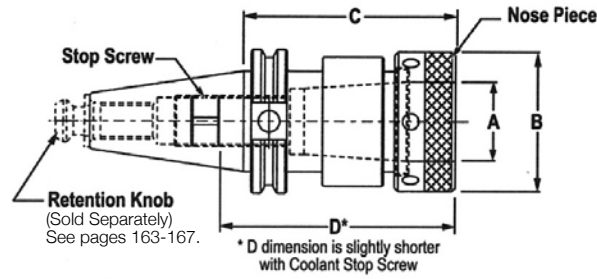

PART NO. W/ STOP SCREW	PART NO. W/ COOLANT SEAL STOP SCREW	OLD PART NO. W/ COOLANT SEAL STOP SCREW	A RANGE	COLLET SERIES	B DIA.	C PROJ.	D MAX.	NOSE PIECE	STOP SCREW	COOLANT SEAL SCREW	SPANNER WRENCH (NOT INCLUDED)
40 V-FLANGE											
C40-TG10-300	C40-TG10C-300	940-503(C)	0.093-1.000	TG100	2.50	3.00	3.72	111-TG10S	101-003	102-003	112-001
* C40-TG10-500	C40-TG10C-500	940-505(C)	0.093-1.000	TG100	2.50	5.00	5.72	111-TG10S	101-003	102-003	112-001
* C40-TG10-600	C40-TG10C-600		0.093-1.000	TG100	2.50	6.00	7.25	111-TG10S	101-003	102-003	112-001
* C40-TG10-650	C40-TG10C-650	940-506(C)	0.093-1.000	TG100	2.50	6.50	7.22	111-TG10S	101-003	102-003	112-001
* C40-TG15-488	C40-TG15C-488		0.500-1.500	TG150	3.50	4.88	4.31	111-TG15S	101-013	102-013	112-002
45 V-FLANGE											
* C45-TG10-300	C45-TG10C-300	945-503(C)	0.093-1.000	TG100	2.50	3.00	4.25	111-TG10S	101-003	102-003	112-001
* C45-TG10-400	C45-TG10C-400	945-504(C)	0.093-1.000	TG100	2.50	4.00	5.25	111-TG10S	101-003	102-003	112-001
* C45-TG10-550	C45-TG10C-550	945-506A(C)	0.093-1.000	TG100	2.50	5.50	6.00	111-TG10S	101-003	102-003	112-001
* C45-TG10-600	C45-TG10C-600	945-506(C)	0.093-1.000	TG100	2.50	6.00	7.25	111-TG10S	101-003	102-003	112-001
* C45-TG10-750	C45-TG10C-750	945-508A(C)	0.093-1.000	TG100	2.50	7.50	6.00	111-TG10S	101-003	102-003	112-001
* C45-TG15-300	C45-TG15C-300	945-553(C)	0.500-1.500	TG150	3.50	3.00	4.25	111-TG15S	101-007	102-007	112-002
* C45-TG15-400	C45-TG15C-400	945-554(C)	0.500-1.500	TG150	3.50	4.00	5.25	111-TG15S	101-007	102-007	112-002
* C45-TG15-600	C45-TG15C-600	945-556(C)	0.500-1.500	TG150	3.50	6.00	7.25	111-TG15S	101-007	102-007	112-002
* C45-TG15-800	C45-TG15C-800	945-558(C)	0.500-1.500	1G150	3.50	8.00	9.25	111-TG15S	101-007	102-007	112-002
50 V-FLANGE											
* C50-TG10-300	C50-TG10C-300	950-502(C)	0.093-1.000	TG100	2.50	3.00	4.75	111-TG10S	101-003	102-003	112-001
C50-TG10-350	C50-TG10C-350	950-503(C)	0.093-1.000	TG100	2.50	3.50	5.25	111-TG10S	101-003	102-003	112-001
C50-TG10-550	C50-TG10C-550	950-505(C)	0.093-1.000	TG100	2.50	5.50	7.25	111-TG10S	101-003	102-003	112-001
* C50-TG10-750	C50-TG10C-750	950-507(C)	0.093-1.000	TG100	2.50	7.50	9.25	111-TG10S	101-003	102-003	112-001
C50-TG15-300	C50-TG15C-300	950-552(C)	0.500-1.500	TG150	3.50	3.00	4.50	111-TG15S	101-007	102-007	112-002
* C50-TG15-350	C50-TG15C-350	950-553(C)	0.500-1.500	TG150	3.50	3.50	5.00	111-TG15S	101-007	102-007	112-002
* C50-TG15-550	C50-TG15C-550	950-555(C)	0.500-1.500	TG150	3.50	5.50	7.00	111-TG15S	101-007	102-007	112-002
* C50-TG15-750	C50-TG15C-750	950-557(C)	0.500-1.500	TG150	3.50	7.50	9.00	111-TG15S	101-007	102-007	112-002

*** Outgoing Items**

- Supplied with nosepiece and standard stop screw



Visit our website at www.coolantfedtooling.com for technical information and our latest product offerings.



V-FLANGE SINGLE ANGLE COLLET CHUCKS WITH POSITIVE SEAL STOP SCREWS

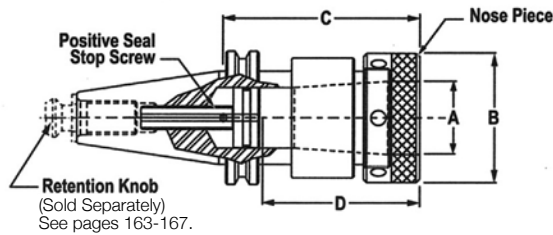

TG Style Collets
See page 146.



PART NUMBER	OLD PART NO.	A RANGE	COLLET SERIES	B. DIA.	C PROJ.	D MAX.	NOSE PIECE	POSITIVE SEAL STOP SCREW	SPANNER WRENCH (NOT INCLUDED)
40 V-FLANGE									
C40-TG10P-400	940-504P	0.093-1.00	TG100	2.50	4.00	4.31	111-TG10S	104-004	112-001
45 V-FLANGE									
* C45-TG10P-400	945-504P	0.093-1.00	TG100	2.50	4.00	4.31	111-TG10S	104-005	112-001
* C45-TG15P-400	945-554P	0.500-1.50	TG150	3.50	4.00	4.75	111-TG15S	104-008	112-002
50 V-FLANGE									
C50-TG10P-400	950-504P	0.093-1.00	TG100	2.50	4.00	4.56	111-TG10S	104-005	112-001
* C50-TG15P-400	950-554P	0.500-1.50	TG150	3.50	4.00	4.75	111-TG15S	104-008	112-002

* Outgoing Items

- Industry standard Single Angle Collet Chucks with the added feature of Positive Seal Fine Adjustment Stop Screws
- Supplied with nosepiece and stop screw

V-FLANGE DOUBLE ANGLE COLLET CHUCKS

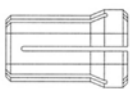

DA Style Collets
See page 147.

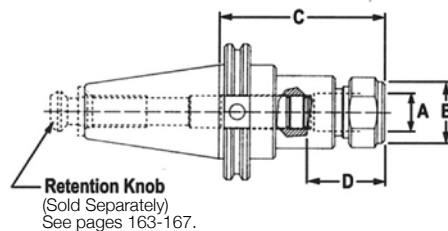

STANDARD TOOL HOLDERS

PART NO. W/ STOP SCREW	PART NO. W/ COOLANT SEAL STOP SCREW	A RANGE	COLLET SERIES	B. DIA.	C PROJ.	D MAX.	NOSE PIECE	STOP SCREW	COOLANT SEAL SCREW	SPANNER WRENCH (NOT INCLUDED)
40 V-FLANGE										
* C40-DA18-295	C40-DA18C-295	0.047-0.750	DA180	1.69	2.95	2-3/8	111-DA18	101-002	102-002	112-019
* C40-DA18-400	C40-DA18C-400	0.047-0.750	DA180	1.69	4.00	3-3/8	111-DA18	101-002	102-002	112-019

* Outgoing Items

- Supplied with nosepiece and stop screw



Visit our website at www.coolantfedtooling.com for technical information and our latest product offerings.



V-FLANGE DOUBLE ANGLE COLLET CHUCKS WITH POSITIVE SEAL STOP SCREW

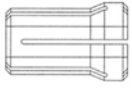

DA Style Collets

See pages 147.

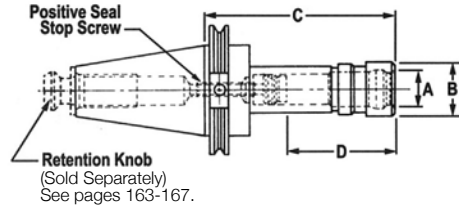

PART NUMBER	OLD PART NO.	A RANGE	COLLET SERIES	B DIA.	C PROJ.	D MAX.	NOSE PIECE	STOP SCREW	SPANNER WRENCH (NOT INCLUDED)
40 V-FLANGE									
* C40-DA18P-6	940-589	0.047-0.750	DA180	1.50	6.00	3.50	111-DA18	104-002	112-019
50 V-FLANGE									
* C50-DA18P-6	950-589	0.047-0.750	DA180	1.50	6.00	4.50	111-DA18	104-002	112-019

*** Outgoing Items**

- Supplied with nosepiece and stop screw

V-FLANGE ER COLLET CHUCKS

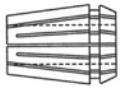

ER Style Collets

See page 145.

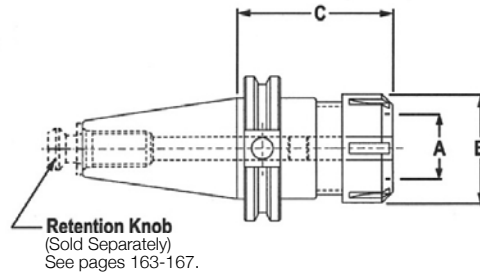

PART NUMBER	A RANGE	COLLET SERIES	B DIA.	C PROJ.	NOSE PIECE	OPTIONAL STOP SCREW	SPANNER WRENCH (NOT INCLUDED)
40 V-FLANGE							
C40-ER16-400	0.020-0.393	ER16	1.109	4	115-015	101-023	112-102
C40-ER20-400	0.040-0.511	ER20	1.344	4	115-016	101-023	112-103
C40-ER32-400	0.080-0.787	ER32	1.968	4	115-017	101-024	112-106
* C40-ER32-600	0.080-0.787	ER32	1.968	6	115-017	101-024	112-106
50 V-FLANGE							
* C50-ER16-400	0.020-0.393	ER16	1.109	4	115-015	101-023	112-102
* C50-ER16-600	0.020-0.393	ER16	1.109	6	115-015	101-023	112-102
* C50-ER20-400	0.040-0.511	ER20	1.344	4	115-016	101-023	112-103
C50-ER32-400	0.080-0.787	ER32	1.968	4	115-017	101-024	112-106
* C50-ER32-600	0.080-0.787	ER32	1.968	6	115-017	101-024	112-106

*** Outgoing Items**

- Precision gripping within 0.0003"
- Threaded through holes for backup screws and coolant
- Greater precision allows for improved tool life and precise machine tolerances
- Supplied with nosepiece
- For optional stop screws see page 156



Visit our website at www.coolantfedtooling.com for technical information and our latest product offerings.



V-FLANGE END MILL HOLDERS

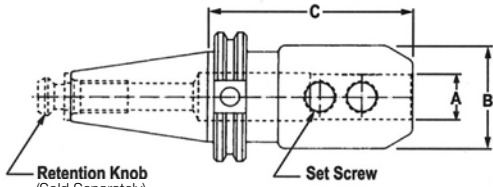

Retention Knob
(Sold Separately)
See pages 163-167.



PART NUMBER	OLD PART NO.	A I.D.	B DIA.	C PROJ.	SET SCREW SIZE
40 V-FLANGE					
* C40-EM12-300		0.125	1.00	3.00	6-32
C40-EM18-250		0.187	0.69	2.50	6-32
* C40-EM25-250		0.250	0.69	2.50	1/4-28
C40-EM31-250		0.312	1.00	2.50	1/4-28
C40-EM37-250		0.375	1.00	2.50	3/8-24
* C40-EM37-450		0.375	1.00	4.50	3/8-24
C40-EM50-175		0.500	1.75	1.75	7/16-20
* C40-EM50-462		0.500	1.25	4.62	7/16-20
* C40-EM50-662		0.500	1.25	6.62	7/16-20
C40-EM62-175		0.625	1.75	1.75	9/16-18
C40-EM62-300		0.625	1.50	3.00	9/16-18
* C40-EM62-338	940-620	0.625	1.75	3.38	1/2-13
* C40-EM62-575		0.625	1.62	5.75	9/16-18
C40-EM75-175		0.750	1.75	1.75	5/8-18
C40-EM75-300		0.750	1.75	3.00	5/8-18
C40-EM75-338	940-750	0.750	1.75	3.38	5/8-11
* C40-EM75-575		0.750	1.75	5.75	5/8-18
* C40-EM87-338	940-870	0.875	1.75	3.38	5/8-11
C40-EM10-300		1.000	1.95	3.00	3/4-16
* C40-EM10-338	940-100	1.000	2.12	3.38	5/8-11
C40-EM10-400		1.000	2.25	4.00	3/4-16
C40-EM12-200		1.250	2.25	2.00	3/4-16
* C40-EM12-425	940-120	1.250	2.50	4.25	3/4-16
* C40-EM12-625		1.250	2.50	6.25	3/4-16
C40-EM15-462	940-150	1.500	2.75	4.62	3/4-16
45 V-FLANGE					
* C45-EM37-225	945-370	0.375	1.50	2.25	3/8-16
* C45-EM37-300	945-370A	0.375	1.50	3.00	3/8-16
* C45-EM37-250		0.375	1.00	2.50	3/8-24
* C45-EM50-300	945-500	0.500	1.50	3.00	3/8-16
* C45-EM50-262		0.500	1.38	2.62	7/16-20
* C45-EM62-300	945-620	0.625	1.50	3.00	1/2-13
* C45-EM62-375		0.625	1.62	3.75	9/16-18
* C45-EM75-300	945-750	0.750	2.00	3.00	5/8-11
* C45-EM75-375	945-750A	0.750	1.75	3.75	5/8-11
* C45-EM87-375	945-870	0.875	2.00	3.75	5/8-11
* C45-EM10-400	945-100	1.000	2.50	4.00	3/4-16
* C45-EM12-400	945-120	1.250	2.62	4.00	3/4-16
* C45-EM15-462	945-150	1.500	2.75	4.62	3/4-16
* C45-EM15-400		1.500	2.62	4.00	3/4-16
* C45-EM20-525	945-200E	2.000	3.75	5.25	1-14

* **Outgoing Items**

- Same holder used for both coolant-thru-the-spindle and non coolant-fed applications
- Holders supplied with set screws



PART NUMBER	OLD PART NO.	A I.D.	B DIA.	C PROJ.	SET SCREW SIZE
50 V-FLANGE					
C50-EM18-250		0.187	0.69	2.50	6-32
C50-EM25-250		0.250	0.69	2.50	1/4-28
C50-EM31-250		0.312	1.00	2.50	1/4-28
* C50-EM37-300	950-370	0.375	1.50	3.00	3/8-24
C50-EM37-450		0.375	1.00	4.50	3/8-24
* C50-EM50-300	950-500	0.500	1.50	3.00	7/16-20
C50-EM50-462		0.500	1.38	4.62	7/16-20
C50-EM62-375		0.625	1.62	3.75	9/16-18
C50-EM75-400	950-750	0.750	2.50	4.00	5/8-18
* C50-EM75-575		0.750	1.75	5.75	5/8-18
* C50-EM87-400	950-870	0.875	2.50	4.00	5/8-18
C50-EM87-375		0.875	2.00	3.75	5/8-18
C50-EM10-400		1.000	2.25	4.00	3/4-16
* C50-EM10-262		1.000	2.75	2.62	3/4-16
* C50-EM10-600	950-106	1.000	2.25	6.00	3/4-16
* C50-EM10-800	950-108	1.000	2.25	8.00	3/4-16
* C50-EM12-400	950-120	1.250	2.50	4.00	3/4-16
* C50-EM12-600		1.250	2.50	6.00	3/4-16
C50-EM15-400		1.500	2.75	4.00	3/4-16
* C50-EM20-562		2.000	3.75	5.62	1-14
* C50-EM20-762	950-208	2.000	3.75	7.62	1-14

* **Outgoing Items**

End Mill Holder Set Screws

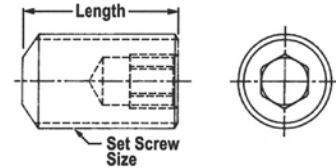

SET SCREW SIZE	LENGTH	PART NUMBER
6-32	1/4	001-801
* 1/4-28	1/4	001-803
* 3/8-16	5/16	001-804
* 3/8-24	5/16	001-805
* 7/16-20	3/8	001-807
* 1/2-13	3/8	001-808
* 9/16-18	1/2	001-811
* 5/8-11	1/2	001-812
* 5/8-18	1/2	001-813
* 3/4-16	5/8	001-815
* 1-14	7/8	001-817

* **Outgoing Items**



Visit our website at www.coolantfedtooling.com for technical information and our latest product offerings.

STANDARD TOOL HOLDERS



V-FLANGE SHELL MILL HOLDERS • COOLANT-FED AND NON COOLANT-FED

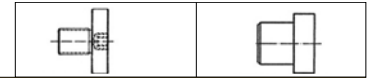
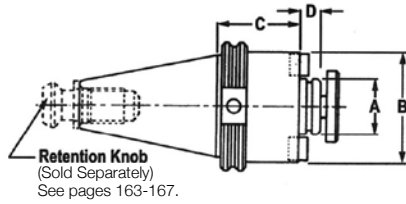

PART NUMBER	OLD PART NUMBER	A PILOT DIA.	B DIA.	C PROJ.	D	ARBOR SCREW	DRIVE KEY / PIN
40 V-FLANGE • NON COOLANT-FED							
* C40-SM50-138		0.50	1.75	1.38	0.560	200-001	201-001
* C40-SM50-350		0.50	1.75	3.50	0.560	200-001	201-001
* C40-SM75-138		0.75	1.75	1.38	0.680	200-002	201-002
* C40-SM75-350		0.75	1.75	3.50	0.680	200-002	201-002
* C40-SM10-100		1.00	2.19	1.00	0.680	200-003	201-003
* C40-SM10-200	940-010	1.00	2.19	2.06	0.680	200-003	201-003
* C40-SM10-400		1.00	2.19	4.00	0.680	200-003	201-003
* C40-SM12-200	940-025	1.25	2.75	2.12	0.680	200-005	201-004
* C40-SM12-400		1.25	2.75	4.00	0.680	200-005	201-004
* C40-SM15-250		1.50	3.62	2.50	0.940	200-007	201-005
* C40-SM15-400		1.50	3.62	4.00	0.940	200-007	201-005
40 V-FLANGE • COOLANT-FED							
* C40-SM10C-194 **	940-011	1.00	2.75	1.94	1.437	200-003	201-003
* C40-SM12C-343 **	940-026	1.25	4.50	3.43	1.437	200-005	201-004
45 V-FLANGE • NON COOLANT-FED							
* C45-SM50-150		0.50	1.56	1.50	0.560	200-001	201-001
* C45-SM75-150		0.75	1.94	1.50	0.680	200-002	201-002
* C45-SM10-200		1.00	2.44	2.00	0.680	200-003	201-003
* C45-SM10-225	945-010	1.00	2.00	2.25	0.680	200-005	201-003
* C45-SM12-225	945-025	1.25	2.88	2.25	0.680	200-005	201-004
* C45-SM12-212	945-025A	1.25	2.75	2.12	0.680	200-005	201-004
* C45-SM15-240		1.50	3.94	2.40	0.940	200-007	201-005
* C45-SM15-250	945-056	1.50	3.80	2.50	0.940	200-007	201-005
* C45-SM15-245	945-056A	1.50	3.94	2.45	0.940	200-007	201-005
* C45-SM15-400		1.50	3.94	4.00	0.940	200-007	201-005
* C45-SM15-405	945-058	1.50	3.80	4.05	0.940	200-007	201-005
* C45-SM20-212		2.00	4.44	2.12	0.940	200-009	201-006
45 V-FLANGE • COOLANT-FED							
* C45-SM10C-200 **	945-011	1.00	2.25	2.00	1.437	200-003	201-003
* C45-SM12C 343 **	945-026	1.25	2.87	3.43	1.437	200-005	201-004
* C45-SM15C-400 **	945-057	1.50	3.80	4.00	1.437	200-007	201-005
50 V-FLANGE • NON COOLANT-FED							
* C50-SM50-150		0.50	1.56	1.50	0.560	200-001	201-001
* C50-SM50-200	950-050	0.50	1.25	2.00	0.560	200-001	200-001
* C50-SM50-550		0.50	1.56	5.50	0.560	200-001	201-001
* C50-SM75-150		0.75	1.94	1.50	0.680	200-002	201-002
* C50-SM75-350		0.75	1.94	3.50	0.680	200-002	201-002
* C50-SM10-200	950-010	1.00	2.75	2.00	0.680	200-003	201-003
* C50-SM10-400	950-012	1.00	2.75	4.00	0.680	200-003	201-003
* C50-SM12-225	950-025	1.25	2.87	2.25	0.680	200-005	201-004
* C50-SM12-550		1.25	2.75	5.50	0.940	200-005	201-004
* C50-SM15-240		1.50	3.94	2.40	0.940	200-007	201-005
* C50-SM15-245	950-056	1.50	3.80	2.45	0.940	200-007	201-005
* C50-SM15-400		1.50	3.94	4.00	0.940	200-007	201-005
* C50-SM15-405	950-058	1.50	3.80	4.05	0.940	200-007	201-005
* C50-SM15-600		1.50	3.94	6.00	0.940	200-007	201-005
* C50-SM15-605	950-059	1.50	3.80	6.05	0.940	200-007	201-005
* C50-SM20-240	950-200	2.00	4.44	2.40	0.940	200-009	201-006
* C50-SM20-400		2.00	4.44	4.00	0.940	200-009	201-006
* C50-SM20-600		2.00	4.44	6.00	0.940	200-009	201-006
* C50-SM25-240		2.50	4.88	2.40	0.940	200-009	201-006

* Outgoing Items

• Shell Mill Holders are supplied with drive keys and arbor screws



Visit our website at www.coolantfedtooling.com for technical information and our latest product offerings.

Coolant-Fed

** Designed for Coolant-Fed Milling Cutter



V-FLANGE FACE MILL HOLDERS • 4 MOUNTING HOLES

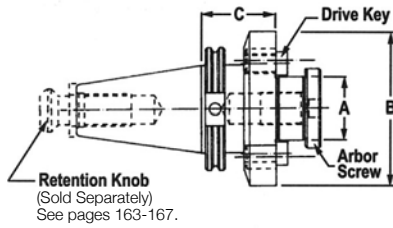

PART NUMBER	A PILOT DIA.	B DIA.	C PROJ.	ARBOR SCREW NO.	DRIVE KEY/PIN
45 V-FLANGE					
* C45-FM20-212	2.0	4.87	2.12	200-009	201-006
* C45-FM20-400	2.0	4.87	4.00	200-009	201-006
* C45-FM20-600	2.0	4.87	6.00	200-009	201-006
50 V-FLANGE					
* C50-FM20-240	2.0	4.87	2.40	200-011	201-007
* C50-FM20-400	2.0	4.87	4.00	200-011	201-007
* C50-FM20-600	2.0	4.87	6.00	200-011	201-007
* C50-FM25-240	2.5	4.87	2.40	200-011	201-007
* C50-FM25-400	2.5	4.87	4.00	200-011	201-007
* C50-FM25-600	2.5	4.87	6.00	200-011	201-007

*** Outgoing Items**

- Holders have (4) mounting holes with 5/8-11 threads on a 4" bolt circle

V-FLANGE JACOBS TAPER HOLDERS

PART NUMBER	OLD PART NUMBER	J.T. SIZE	B PROJ.	C PROJ.
40 V-FLANGE				
* C40-JT1-215		1	2.15	1.49
* C40-JT2-243		2	2.43	1.56
* C40-JT3-281		3	2.81	1.59
* C40-JT4-325	940-334	4	3.25	1.59
* C40-JT5-338	940-335	5	3.38	1.50
* C40-JT6-359	940-336	6	3.59	1.59
* C40-JT33-250	940-332	33	2.50	1.50
* C40-JT33-259		33	2.59	1.59
45 V-FLANGE				
* C45-JT1-237	945-331	1	2.37	1.37
* C45-JT1-215		1	2.15	1.49
* C45-JT2-243		2	2.43	1.56
* C45-JT3-275	945-333	3	2.75	1.53
* C45-JT3-281		3	2.81	1.59
* C45-JT4-325		4	3.25	1.59
* C45-JT6-259		6	2.59	1.59
* C45-JT33-259		33	2.59	1.59

*** Outgoing Items**

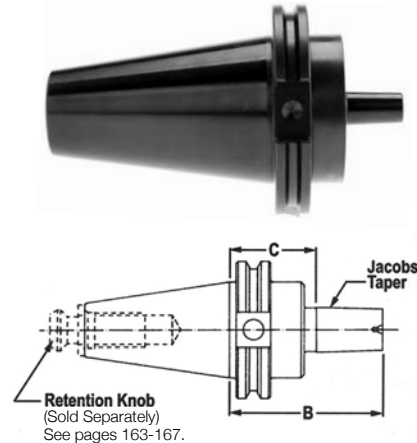

PART NUMBER	OLD PART NUMBER	J.T. SIZE	B PROJ.	C PROJ.
50 V-FLANGE				
* C50-JT1-215		1	2.15	1.49
* C50-JT2-243		2	2.43	1.56
* C50-JT3-280	950-333	3	2.80	1.59
* C50-JT3-281		3	2.81	1.59
* C50-JT4-325	950-334	4	3.25	1.59
* C50-JT5-338	950-335	5	3.38	1.50
* C50-JT6-259	950-336	6	2.59	1.59
* C50-JT33-259	950-332	33	2.59	1.59

*** Outgoing Items**

STANDARD
TOOL HOLDERS



Visit our website at www.coolantfedtooling.com for technical information and our latest product offerings.



V-FLANGE MORSE TAPER HOLDERS • DUAL AND END ENTRY

Dual Entry

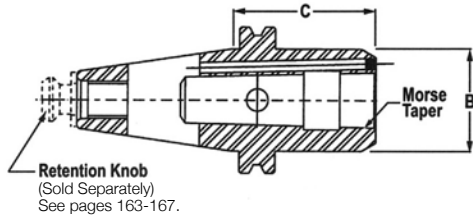

End Entry

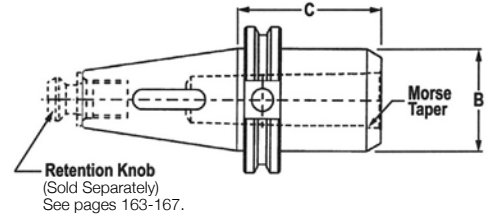

Dual Entry

PART NUMBER	OLD PART NO.	M.T. SIZE	B DIA.	C PROJ.
40 V-FLANGE				
C40-MT2-175D	940-022	2	1.75	1.75
C40-MT3-250D	940-033	3	1.75	2.50
C40-MT4-350D	940-044	4	2.00	3.50
45 V-FLANGE				
* C45-MT2-150D	945-022	2	2.25	1.50
* C45-MT3-231D	945-033	3	2.25	2.31
* C45-MT4-318D	945-044	4	2.25	3.18
* C45-MT5-475D	945-055	5	2.63	4.75
50 V-FLANGE				
C50-MT2-200D	950-022	2	1.25	2.00
C50-MT3-250D	950-033	3	1.62	2.50
C50-MT4-338D	950-044	4	2.00	3.37
C50-MT5-475D	950-055	5	2.75	4.75

* Outgoing Items

- Dual Entry style provides coolant-thru-the-spindle to tang end of tooling or directly to side of tooling taper.

End Entry

PART NUMBER	OLD PART NO.	M.T. SIZE	B DIA.	C PROJ.
40 V-FLANGE				
C40-MT1-175E		1	1.00	1.75
C40-MT2-175E	940-002	2	1.75	1.75
C40-MT2-219E		2	1.25	2.19
C40-MT3-250E	940-003	3	1.75	2.50
C40-MT3-275E		3	1.75	2.75
C40-MT4-350E	940-004	4	2.00	3.50
C40-MT4-356E		4	2.00	3.56
45 V-FLANGE				
* C45-MT2-150E	945-002	2	2.25	1.50
* C45-MT3-231E	945-003	3	2.25	2.31
* C45-MT4-318E	945-004	4	2.25	3.18
* C45-MT5-475E	945-005	5	2.63	4.75
50 V-FLANGE				
C50-MT2-200E	950-002	2	1.25	2.00
C50-MT3-250E	950-003	3	1.62	2.50
C50-MT4-337E	950-004	4	2.00	3.37
C50-MT5-475E	950-005	5	2.75	4.75

* Outgoing Items

- End Entry provides coolant-thru-the-spindle to tang end of tooling only. (Will work for non-coolant applications)

V-FLANGE BORING BAR BLANKS

PART NUMBER	OLD PART NO.	A DIA.	B PROJ.
40 V-FLANGE			
C40-BB4-11		3.88	11.00
45 V-FLANGE			
* C45-BB4-64	945-778B	4.00	6.40
* C45-BB4-110	945-779B	4.00	11.00
50 V-FLANGE			
C50-BB4-11	950-778B	3.88	11.00
C50-BB6-07	950-780B	6.12	7.00
C50-BB4-17	950-778B/S	4.00	17.00

* Outgoing Items

- 28-32 RC Body

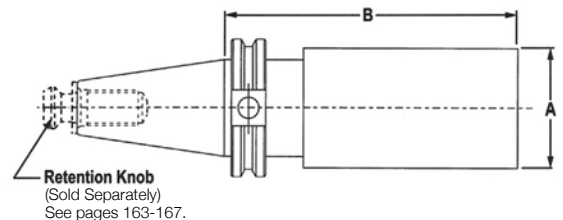

Visit our website at www.coolantfedtooling.com for technical information and our latest product offerings.



BT SINGLE ANGLE COLLET CHUCKS

TG Style Collets
See page 146.

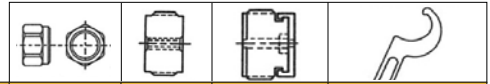
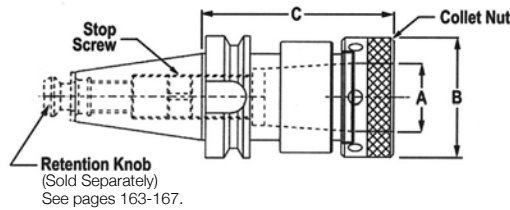
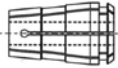

PART NO. WITH STOP SCREW	OLD PART NO.	PART NO. W/ COOLANT SEAL STOP SCREW	OLD PART NO.	A RANGE	COLLET SERIES	B DIA.	C PROJ.	NOSE PIECE	STOP SCREW	COOLANT SEAL SCREW	SPANNER WRENCH (NOT INCLUDED)
BT 40											
* BT40-TG10-350	BT940-503	BT40-TG10C-350	BT940-503C	0.093-1.00	TG100	2.5	3.5	111-TG10S	101-003	102-003	112-001
* BT40-TG10-550	-	BT40-TG10C-550	-	0.093-1.00	TG100	2.5	5.5	111-TG10S	101-003	102-003	112-001
BT 50											
* BT50-TG10-350	BT950-503	BT50-TG10C-350	BT950-503C	0.093-1.00	TG100	2.5	3.5	111-TG10S	101-003	102-003	112-001
* BT50-TG10-600	BT950-505	BT50-TG10C-600	BT950-505C	0.093-1.00	TG100	2.5	6.0	111-TG10S	101-003	102-003	112-001
* BT50-TG15-350	BT950-533	BT50-TG15C-350	BT950-533C	0.500-1.50	TG150	3.5	3.5	111-TG15S	101-014	102-007	112-002

* Outgoing Items

- Supplied with nosepiece and stop screw

BT • ER COLLET CHUCKS

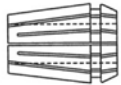

ER Style Collets

See page 145.

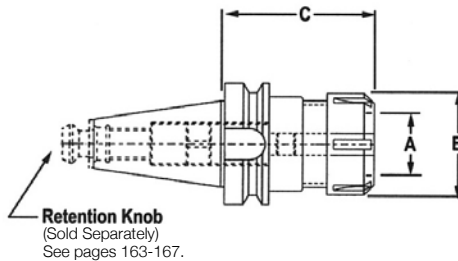

STANDARD TOOL HOLDERS

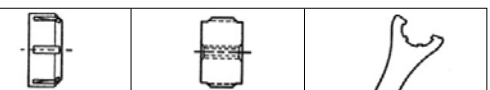

PART NUMBER	A RANGE	COLLET SERIES	B DIA.	C PROJ.	NOSE PIECE	STOP SCREW	SPANNER WRENCH (NOT INCLUDED)
BT 40							
* BT40-ER20-393	0.040-0.511	ER20	1.344	3.937	115-009	101-023	112-103
* BT40-ER32-400	0.080-0.787	ER32	1.968	4.000	115-006	101-024	112-106
BT 50							
* BT50-ER20-393	0.040-0.511	ER20	1.344	3.937	115-009	101-023	112-103
* BT50-ER32-400	0.040-0.787	ER32	1.968	4.000	115-006	101-024	112-106

* Outgoing Items

- Precision gripping within 0.0003"
- Threaded through holes for backup screws and coolant
- Greater precision allows for improved tool life and precise machine tolerances
- Supplied with nosepiece
- For optional stop screws see page 156



Visit our website at www.coolantfedtooling.com for technical information and our latest product offerings.



BT END MILL HOLDERS

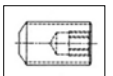
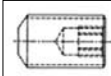
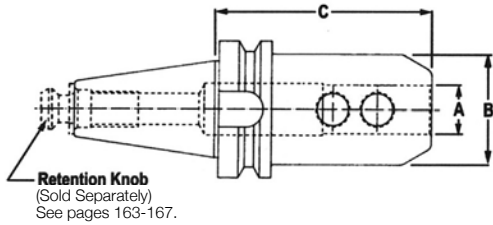

PART NUMBER	OLD PART NO.	A I.D.	B DIA.	C PROJ.	SET SCREW SIZE
BT 40					
BT40-EM37-250	BT940-370	0.375	1.12	2.50	3/8-24
* BT40-EM37-400		0.375	1.12	4.00	3/8-24
BT40-EM50-175		0.500	1.75	1.75	7/16-20
* BT40-EM50-250	BT940-500	0.500	1.50	2.50	7/16-20
BT40-EM50-400		0.500	1.50	4.00	7/16-20
BT40-EM62-250	BT940-620	0.625	1.62	2.50	9/16-18
* BT40-EM62-400		0.625	1.62	4.00	9/16-18
* BT40-EM75-250	BT940-750	0.750	1.75	2.50	5/8-18
BT40-EM75-400		0.750	1.75	4.00	5/8-18
* BT40-EM87-350		0.875	2.17	3.50	5/8-18
* BT40-EM10-175		1.000	2.38	1.75	3/4-16
BT40-EM10-350	BT940-100	1.000	2.38	3.50	3/4-16
BT40-EM12-350	BT940-120	1.250	2.50	3.50	3/4-16
BT40-EM15-450		1.500	2.75	4.50	3/4-16

*** Outgoing Items**

- End mill holders are supplied with set screws
- See page 127 for additional set screws

PART NUMBER	OLD PART NO.	A I.D.	B DIA.	C PROJ.	SET SCREW SIZE
BT 50					
* BT50-EM37-300		0.375	1.12	3	3/8-24
* BT50-EM50-300	BT950-500	0.500	1.50	3	7/16-20
* BT50-EM50-600		0.500	1.50	6	7/16-20
* BT50-EM62-300	BT950-620	0.625	1.62	3	9/16-18
* BT50-EM62-600		0.625	1.62	6	9/16-18
* BT50-EM75-300	BT950-750	0.750	1.75	3	5/8-18
* BT50-EM75-600		0.750	1.75	6	5/8-18
* BT50-EM87-400	BT950-870	0.875	2.00	4	5/8-18
* BT50-EM10-400	BT950-100	1.000	2.25	4	3/4-16
* BT50-EM10-600		1.000	2.25	6	3/4-16
* BT50-EM12-400	BT950-120	1.250	2.69	4	3/4-16
* BT50-EM12-600		1.250	2.69	6	3/4-16
* BT50-EM15-400		1.500	2.88	4	3/4-16
* BT50-EM20-500	BT950-200E	2.000	3.62	5	1-14

*** Outgoing Items**

BT SHELL MILL HOLDERS

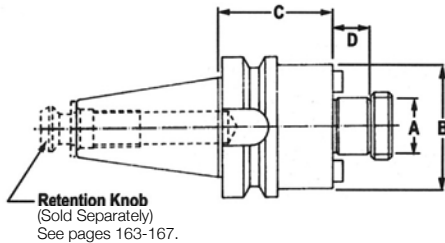

PART NUMBER	OLD PART NUMBER	A PILOT DIA.	B. DIA.	C PROJ.	D	ARBOR SCREW	DRIVE KEY / PIN
BT 40							
BT40-SM75-175	B1940-075	0.75	1.73	1.75	0.68	200-001	201-002
BT40-SM10-175	BT940-010	1.00	2.19	1.75	0.68	200-003	201-003
BT40-SM12-200	BT940-025	1.25	2.75	1.75	0.68	201-005	201-004
BT40-SM15-212	8T940-050	1.50	3.62	1.75	0.94	200-007	201-005
BT 50							
* BT50-SM10-175	BT950-010	1.00	2.19	1.75	0.68	200-003	201-003
* BT50-SM12-175	BT950-025	1.25	2.19	1.75	0.68	200-005	201-004
* BT50-SM15-175	BT950-056	1.50	3.62	1.75	0.94	200-007	201-005
* BT50-SM20-300	BT950-220	2.00	4.88	3.00	0.94	200-009	201-006

*** Outgoing Items**

- Shell Mill Holders are supplied with drive keys and arbor screws



Visit our website at www.coolantfedtooling.com for technical information and our latest product offerings.



BT JACOBS TAPER HOLDERS

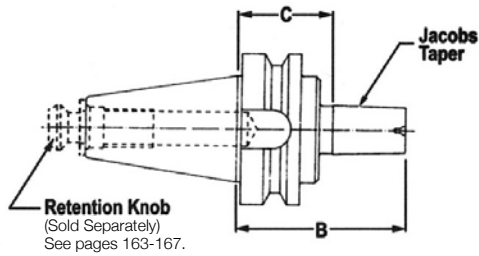

PART NUMBER	J.T. SIZE	B SIZE	C PROJ.
BT 40			
* BT40-JT2-264	2	2.645	1.77
* BT40-JT3-298	3	2.989	1.77
* BT40-JT6-277	6	2.770	1.77
* BT40-JT33-277	33	2.770	1.77

* Outgoing Items

BT MORSE TAPER HOLDERS • END ENTRY

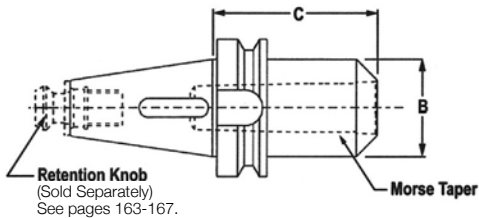

STANDARD
TOOLHOLDERS

PART NUMBER	M.T. SIZE	B DIA.	C PROJ.
BT 40			
* BT40-MT2-177	2	1.27	1.77
* BT40-MT3-295	3	1.58	2.95
* BT40-MT4-374	4	1.97	3.74
BT 50			
* BT50-MT2-236	2	1.27	2.36
* BT50-MT3-295	3	1.58	2.95
* BT50-MT4-374	4	1.97	3.74
* BT50-MT5-413	5	2.25	4.13

* Outgoing Items

• End Entry provides coolant-thru-the-spindle to tang end of tooling only. (Will work for non-coolant applications)



Visit our website at www.coolantfedtooling.com for technical information and our latest product offerings.



STRAIGHT SHANK • SINGLE ANGLE COLLET CHUCKS

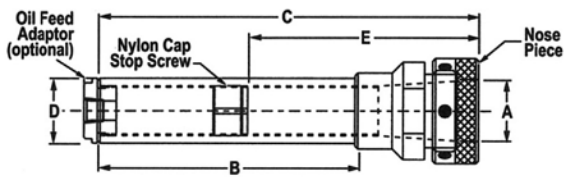

TG Style Collets
See page 146.

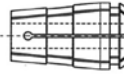

PART NUMBER	OLD PART NO.	A RANGE	COLLET SERIES	B SHANK LGTH.	C OAL	D SHANK DIA.	E MAX.	OPTIONAL OIL FEED ADAPTER	NOSE PIECE	NYLON CAP STOP SCREW	SPANNER WRENCH (NOT INCLUDED)
STRAIGHT SHANK											
SS15-TG10-9	830-004	0.093-1.000	TG100	6.00	8.87	1.50	7.94	108-003	111-TG10S	102-003	112-001
SS20-TG15-12	830-005	0.500-1.500	TG150	8.00	11.69	2.00	11.00	108-004	111-TG15S	102-004	112-002

- Supplied with nosepiece and stop screw
- Oil feed adaptor not standard, available upon request

STRAIGHT SHANK • DOUBLE ANGLE COLLET CHUCKS

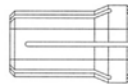
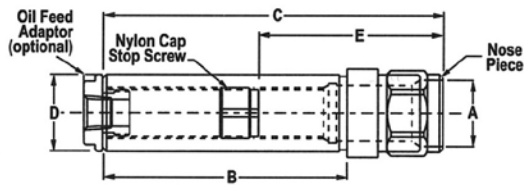

DA Style Collets
See page 147.



PART NUMBER	OLD PART NO.	A RANGE	COLLET SERIES	B SHANK LGTH.	C OAL	D SHANK DIA.	E MAX.	OPTIONAL OIL FEED ADAPTER	NOSE PIECE	NYLON CAP STOP SCREW	SPANNER WRENCH (NOT INCLUDED)
STRAIGHT SHANK											
* SS10-DA18-7	830-001	0.047-0.750	DA180	4.00	6.375	1.00	5.69	108-001	111-DA18	102-001	112-018
* SS12-DA18-8	830-002	0.047-0.750	DA180	6.00	7.625	1.25	6.94	108-002	111-DA18	102-002	112-019
* SS15-DA18-8	830-003	0.047-0.750	DA180	6.00	7.625	1.50	6.94	108-002	111-DA18	102-002	112-019

* Outgoing Items

- Supplied with nosepiece and stop screw
- Oil feed adaptor not standard, available upon request

STRAIGHT SHANK • DOUBLE ANGLE COLLET EXTENSIONS (SLIM LINE)

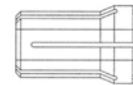
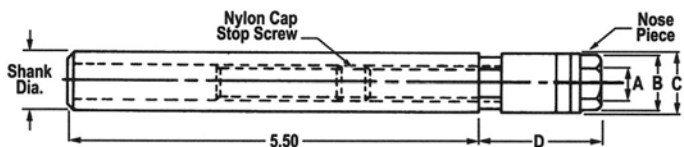

DA Style Collets
See page 147.



PART NO. NON-COOLANT	PART NO. WITH COOLANT SCREW	A RANGE	COLLET SERIES	B	C	D APPROX.	SHANK DIA.	NOSE PIECE	NON-COOLANT STOP SCREW	COOLANT STOP SCREW	SPANNER WRENCH (NOT INCLUDED)
STRAIGHT SHANK											
SS50-DA30-S7	SS50-DA30C-S7	0.031-0.250	DA300	1/2 Hex	0.562	1.312	0.50	111-SDA30	101-022	103-010	112-014
SS75-DA20-S8	SS75-DA20C-S8	0.047-0.390	DA200	11/16 Hex	0.812	1.687	0.75	111-SDA20	101-005	102-005	112-015
SS10-DA10-S8	SS10-DA10C-S8	0.047-0.560	DA100	7/8 Hex	1.062	1.812	1.00	111-SDA10	101-006	102-006	112-017
SS12-DA18-S8	SS12-DA18C-S8	0.047-0.750	DA180	1-1/4 Hex	1.437	1.812	1.25	111-SDA18	101-002	102-002	112-018



MORSE TAPER SINGLE ANGLE COLLET CHUCK WITH COOLANT CROSS HOLE

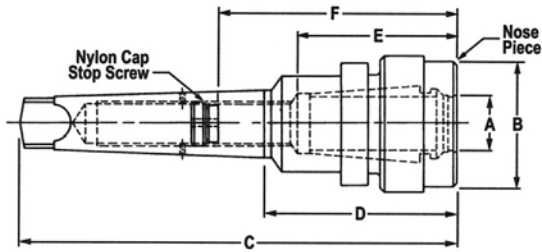

TG Style Collets
See page 146.

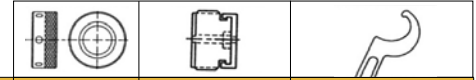

PART NUMBER	OLD PART NUMBER	M.T. SIZE	A RANGE	COLLET SERIES	B DIA.	C OAL	D PROJ.	E DEPTH	F MAX.	NOSE PIECE	NYLON CAP STOP SCREW	SPANNER WRENCH (NOT INCLUDED)
* MT4-TG10-312	832-003	4	0.09-1.00	TG10	2.50	7.75	3.12	2.59	3.75	111-TG10S	102-002	112-001

* Outgoing Items

- Holders furnished with Nylon Stop Screw. Coolant crosshole location to industry standard for Taper Shank Oil Hole Twist Drills

MORSE TAPER DOUBLE ANGLE COLLET CHUCK WITH COOLANT CROSS HOLE

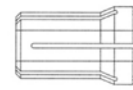
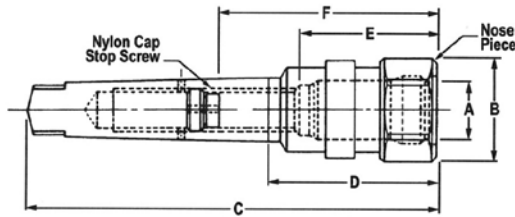

DA Style Collets
See page 147.

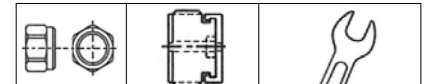

PART NUMBER	OLD PART NO.	M.T. SIZE	A RANGE	COLLET SERIES	B	C OAL	D PROJ.	E DEPTH	F MAX.	NOSE PIECE	NYLON CAP STOP SCREW	SPANNER WRENCH (NOT INCLUDED)
* MT2-DA10-212	829-002	2	0.046-0.562	DA100	1-1/4 Hex	5.06	2.12	1.72	2.25	111-DA10	102-006	112-018
* MT3-DA10-168	829-003	3	0.046-0.562	DA100	1-1/4 Hex	5.38	1.68	1.72	2.25	111-DA10	102-013	112-018
* MT2-DA18-238	832-001	2	0.046-0.750	DA180	1-1/2 Hex	5.38	2.38	2.00	2.75	111-DA18	102-005	112-019
* MT3-DA18-238	832-002	3	0.046-0.750	DA180	1-1/2 Hex	6.06	2.38	2.00	2.50	111-DA18	102-002	112-019
* MT4-DA18-175	832-004	4	0.046-0.750	DA180	1-1/2 Hex	6.38	1.75	-	2.25	111-DA18	102-002	112-019

* Outgoing Items

- Holders furnished with Nylon Stop Screw. Coolant crosshole location to industry standard for Taper Shank Oil Hole Twist Drills

STANDARD TOOL HOLDERS

STRAIGHT SHANK • MORSE TAPER HOLDERS

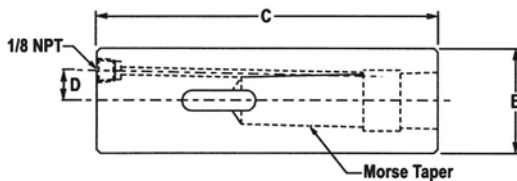

PART NUMBER	OLD PART NUMBER	M.T. SIZE	B DIA.	C OAL	D LOCATION
STRAIGHT SHANK					
SS15-MT1-4C	847-001	1	1.50	4.00	0.47
SS15-MT2-4C	847-002	2	1.50	4.00	0.47
SS17-MT3-6C	847-003	3	1.75	5.75	0.50
SS17-MT4-6C	847-004	4	1.75	5.75	0.59
SS25-MT5-7C	847-005	5	2.50	7.00	0.88



MODULAR TOOLHOLDERS





INTERCHANGEABLE MODULAR TOOLHOLDING SYSTEM - OVERVIEW

MODULAR SHANKS

EXTENSIONS & REDUCERS

TOOLHOLDERS

TOOLS

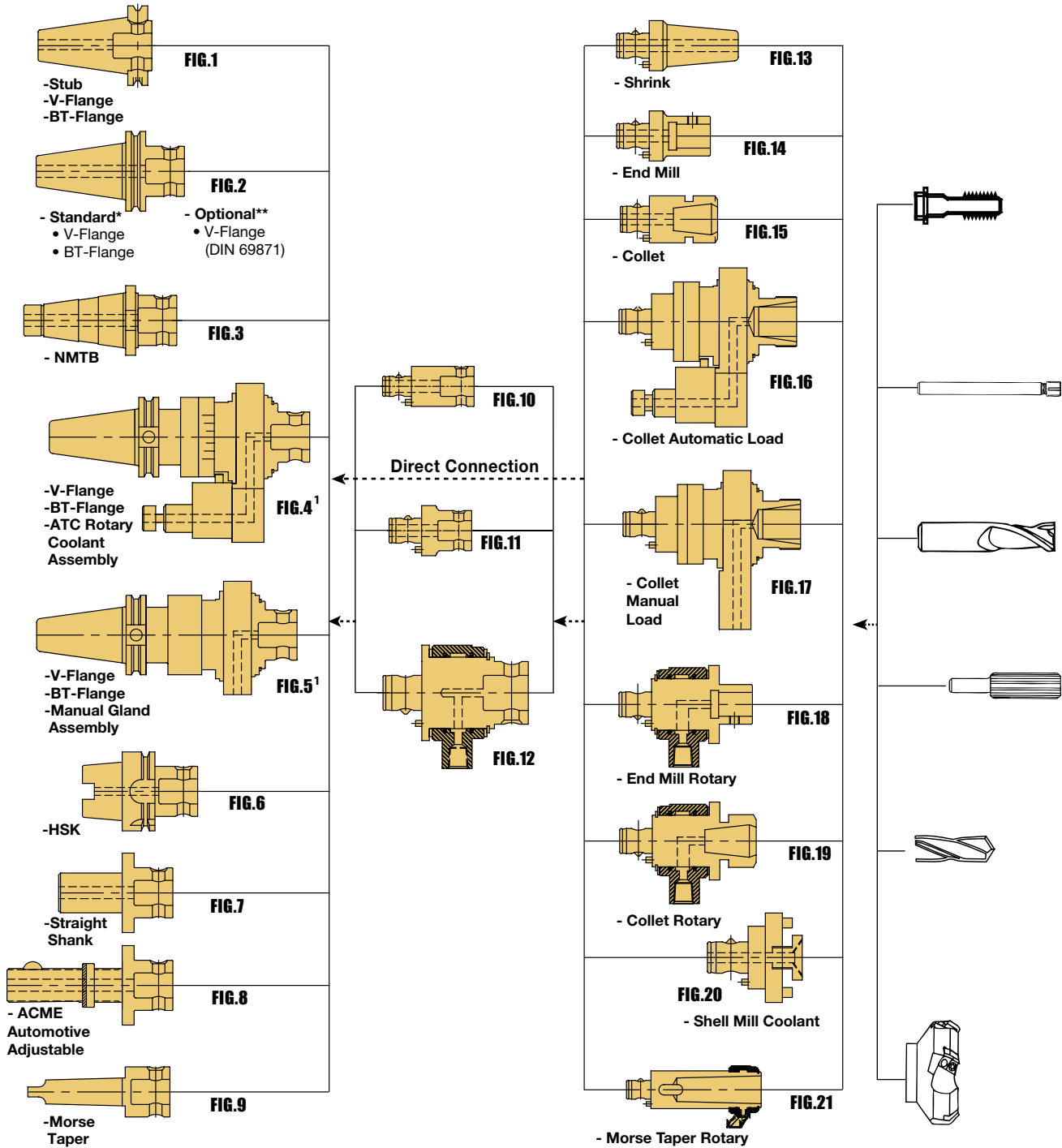

*Through Spindle Coolant ** Through Flange Coolant
¹Available beginning on page 90.



Coming Soon! Figures 3, 6, 7, 8, 9, 12, 13, 16, 17, 18, 19, 20, 21.

Visit our website at www.coolantfedtooling.com for technical information and our latest product offerings.

Interchangeable with KOMET ABS® adapters. ABS® is a registered trademark of KOMET Stahlhalter und Werkzeugfabrik.



MODULAR HOLDERS STUB PROJECTION

NEW

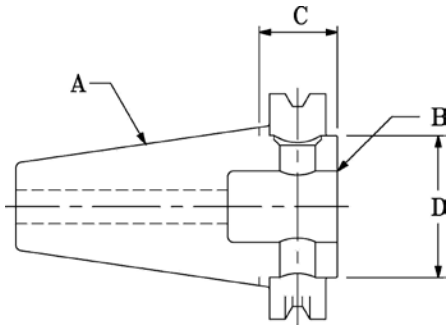

PART NUMBER	EDP NUMBER	A SHANK	B ABS® NUMBER	C PROJECTION (MM)	D CLEARANCE (MM)
MBT40-A25-STUB	M0051	BT 40	25	27.5	25
MBT40-A32-STUB	M0053	BT 40	32	27.5	32
MBT40-A40-STUB	M0055	BT 40	40	27.5	40
MBT40-A50-STUB	M0057	BT 40	50	50.5	50
MBT40-A63-STUB	M0059	BT 40	63	55	63
MBT50-A32-STUB	M0071	BT 50	32	38.5	32
MBT50-A40-STUB	M0073	BT 50	40	38.5	40
MBT50-A50-STUB	M0075	BT 50	50	38.5	50
MBT50-A63-STUB	M0077	BT 50	63	38.5	63
MBT50-A80-STUB	M0079	BT 50	80	75	80
MBT50-A100-STUB	M0081	BT 50	100	90	100
MC40-A25-STUB	M0001	CAT 40	25	22.5	25
MC40-A32-STUB	M0003	CAT 40	32	22.5	32
MC40-A40-STUB	M0005	CAT 40	40	22.5	40
MC40-A50-STUB	M0007	CAT 40	50	58	52
MC40-A63-STUB	M0009	CAT 40	63	65	63
MC50-A32-STUB	M0021	CAT 50	32	22.5	32
MC50-A40-STUB	M0023	CAT 50	40	22.5	40
MC50-A50-STUB	M0025	CAT 50	50	45	50
MC50-A63-STUB	M0027	CAT 50	63	50	63
MC50-A80-STUB	M0029	CAT 50	80	70	80
MC50-A100-STUB	M0031	CAT 50	100	100	100



MODULAR HOLDERS STANDARD PROJECTION

NEW

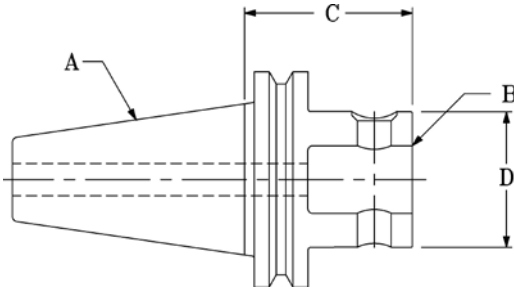

PART NUMBER	EDP NUMBER	A SHANK	B ABS® NUMBER	C PROJECTION (MM)	D CLEARANCE (MM)
MBT40-A25-060	M0061	BT 40	25	60	25
MBT40-A32-060	M0063	BT 40	32	60	32
MBT40-A40-060	M0065	BT 40	40	60	40
MBT40-A50-060	M0067	BT 40	50	60	50
MBT40-A63-070	M0069	BT 40	63	70	63
MBT50-A32-070	M0083	BT 50	32	70	32
MBT50-A40-070	M0085	BT 50	40	70	40
MBT50-A50-070	M0087	BT 50	50	70	50
MBT50-A63-080	M0089	BT 50	63	80	63
MBT50-A80-100	M0091	BT 50	80	100	80
MBT50-A100-110	M0093	BT 50	100	110	100
MC40-A25-060	M0011	CAT 40	25	60	25
MC40-A32-060	M0013	CAT 40	32	60	32
MC40-A40-060	M0015	CAT 40	40	60	40
MC40-A50-075	M0017	CAT 40	50	75	50
MC40-A63-090	M0019	CAT 40	63	90	63
MC50-A32-060	M0033	CAT 50	32	60	32
MC50-A40-060	M0035	CAT 50	40	60	40
MC50-A50-060	M0037	CAT 50	50	60	50
MC50-A63-080	M0039	CAT 50	63	80	63
MC50-A80-100	M0041	CAT 50	80	100	80
MC50-A100-125	M0043	CAT 50	100	125	100

MODULAR
TOOLHOLDERS



MODULAR EXTENSIONS

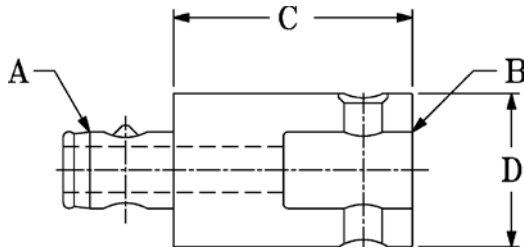

NEW

PART NUMBER	EDP NUMBER	A ABS® NUMBER	B ABS® NUMBER	C LENGTH (MM)	D CLEARANCE (MM)
MA25-045-A25	M0201	25	25	45	25
MA25-060-A25	M0202	25	25	60	25
MA32-050-A32	M0222	32	32	50	32
MA32-070-A32	M0223	32	32	70	32
MA40-040-A40	M0241	40	40	40	40
MA40-060-A40	M0242	40	40	60	40
MA40-090-A40	M0243	40	40	90	40
MA50-050-A50	M0261	50	50	50	50
MA50-065-A50	M0262	50	50	65	50
MA50-100-A50	M0263	50	50	100	50
MA63-060-A63	M0281	63	63	60	63
MA63-085-A63	M0282	63	63	85	63
MA63-125-A63	M0283	63	63	125	63
MA80-070-A80	M0301	80	80	70	80
MA80-085-A80	M0302	80	80	85	80
MA80-125-A80	M0303	80	80	125	80
MA100-085-A100	M0321	100	100	85	100
MA100-125-A100	M0322	100	100	125	100

MODULAR REDUCERS

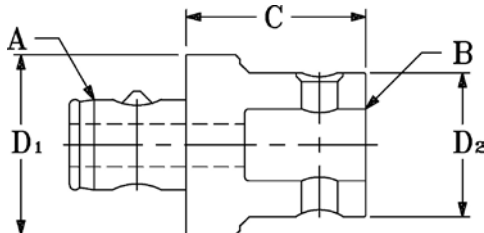

NEW

PART NUMBER	EDP NUMBER	A ABS® NUMBER	B ABS® NUMBER	C LENGTH (MM)	D1 CLEARANCE (MM)	D2 CLEARANCE (MM)
MA32-040-A25	M0401	32	25	40	32	25
MA40-040-A25	M0421	40	25	40	40	25
MA40-040-A32	M0422	40	32	40	40	32
MA50-050-A25	M0441	50	25	50	50	25
MA50-050-A32	M0442	50	32	50	50	32
MA50-050-A40	M0443	50	40	50	50	40
MA63-060-A25	M0461	63	25	60	63	25
MA63-060-A32	M0462	63	32	60	63	32
MA63-060-A40	M0463	63	40	60	63	40
MA63-060-A50	M0464	63	50	60	63	50
MA80-060-A32	M0481	80	32	60	80	32
MA80-060-A40	M0482	80	40	60	80	40
MA80-060-A50	M0483	80	50	60	80	50
MA80-060-A63	M0484	80	63	60	80	63
MA100-080-A40	M0501	100	40	80	100	40
MA100-080-A50	M0502	100	50	80	100	50
MA100-080-A63	M0503	100	63	80	100	63
MA100-080-A80	M0504	100	80	80	100	80



COLLET CHUCKS

NEW

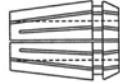
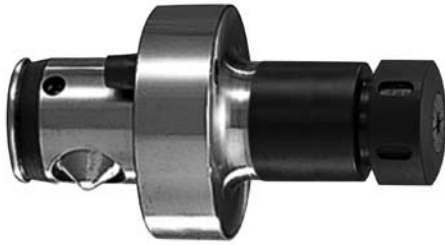

ER Style
Collets

See page 145.

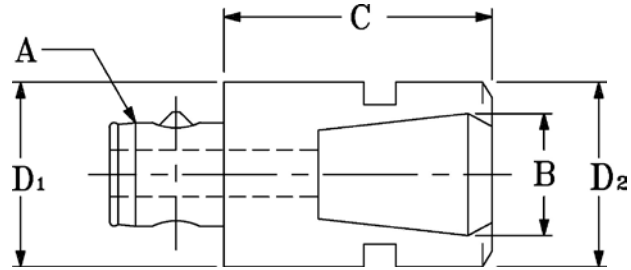

PART NUMBER	EDP NUMBER	A ABS® NUMBER	COLLET STYLE	COLLET RANGE	C PROJECTION (MM)	D1 CLEARANCE (MM)	D2 CLEARANCE MM
MA25-ER16-040	M0601	25	ER 16	0.5mm - 10.0mm	40	25	28
MA32-ER16-040	M0611	32	ER 16	0.5mm - 10.0mm	40	32	28
MA32-ER20-053	M0612	32	ER 20	1.0mm - 13.0mm	53	32	34
MA40-ER16-040	M0621	40	ER 16	0.5mm - 10.0mm	40	40	28
MA40-ER20-053	M0622	40	ER 20	1.0mm - 13.0mm	53	40	34
MA40-ER25-062	M0623	40	ER 25	1.0mm - 16.0mm	62	40	42
MA50-ER16-040	M0631	50	ER 16	0.5mm - 10.0mm	40	50	28
MA50-ER20-053	M0632	50	ER 20	1.0mm - 13.0mm	53	50	34
MA50-ER25-062	M0633	50	ER 25	1.0mm - 16.0mm	62	50	42
MA50-ER32-070	M0634	50	ER 32	2.0mm - 20.0mm	70	50	50
MA63-ER16-040	M0641	63	ER 16	0.5mm - 10.0mm	40	63	28
MA63-ER20-053	M0642	63	ER 20	1.0mm - 13.0mm	53	63	34
MA63-ER25-062	M0643	63	ER 25	1.0mm - 16.0mm	62	63	42
MA63-ER32-070	M0644	63	ER 32	2.0mm - 20.0mm	70	63	50
MA63-ER40-079	M0645	63	ER 40	3.0mm - 26.0mm	79	63	63
MA80-ER16-040	M0651	80	ER 16	0.5mm - 10.0mm	40	80	28
MA80-ER20-053	M0652	80	ER 20	1.0mm - 13.0mm	53	80	34
MA80-ER25-062	M0653	80	ER 25	1.0mm - 16.0mm	62	80	42
MA80-ER32-070	M0654	80	ER 32	2.0mm - 20.0mm	70	80	50
MA80-ER40-079	M0655	80	ER 40	3.0mm - 26.0mm	79	80	63

MODULAR
TOOLHOLDERS



MODULAR END MILL (METRIC)

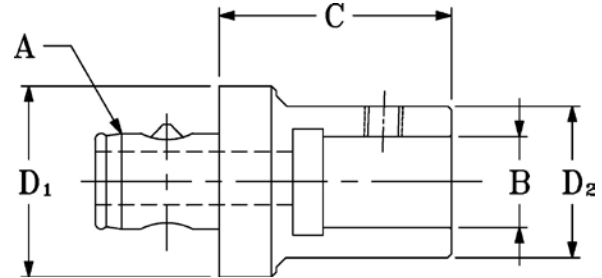

PART NUMBER	EDP NUMBER	A ABS® NUMBER	B BORE SIZE	C PROJECTION (MM)	D1 CLEARANCE (MM)	D2 CLEARANCE (MM)
MA25-EM06MM-055	M0801	25	6 mm	55	25	25
MA25-EM08MM-055	M0802	25	8 mm	55	25	28
MA25-EM10MM-060	M0803	25	10 mm	60	25	35
MA32-EM06MM-055	M0901	32	6 mm	55	32	25
MA32-EM08MM-055	M0902	32	8 mm	55	32	28
MA32-EM10MM-060	M0903	32	10 mm	60	32	35
MA32-EM12MM-065	M0904	32	12 mm	65	32	42
MA40-EM06MM-055	M1001	40	6 mm	55	40	25
MA40-EM08MM-055	M1002	40	8 mm	55	40	28
MA40-EM10MM-060	M1003	40	10 mm	60	40	35
MA40-EM12MM-065	M1004	40	12 mm	65	40	42
MA40-EM16MM-070	M1005	40	16 mm	70	40	48
MA50-EM06MM-055	M1101	50	6 mm	55	50	25
MA50-EM08MM-055	M1102	50	8 mm	55	50	28
MA50-EM10MM-060	M1103	50	10 mm	60	50	35
MA50-EM12MM-065	M1104	50	12 mm	65	50	42
MA50-EM16MM-070	M1105	50	16 mm	70	50	48
MA50-EM20MM-075	M1106	50	20 mm	75	50	52
MA50-EM25MM-075	M1107	50	25 mm	75	50	65
MA63-EM06MM-055	M1201	63	6 mm	55	63	25
MA63-EM08MM-055	M1202	63	8 mm	55	63	28
MA63-EM10MM-060	M1203	63	10 mm	60	63	35
MA63-EM12MM-065	M1204	63	12 mm	65	63	42
MA63-EM16MM-070	M1205	63	16 mm	70	63	48
MA63-EM20MM-075	M1206	63	20 mm	75	63	52
MA63-EM25MM-080	M1207	63	25 mm	80	63	65
MA80-EM16MM-070	M1305	80	16 mm	70	80	48
MA80-EM20MM-075	M1306	80	20 mm	75	80	52
MA80-EM25MM-080	M1307	80	25 mm	80	80	65
MA80-EM32MM-090	M1308	80	32 mm	90	80	72



MODULAR END MILL (INCH)

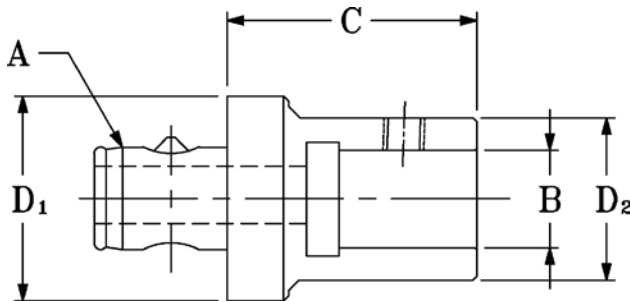

PART NUMBER	EDP NUMBER	A ABS® NUMBER	B BORE SIZE	C PROJECTION (MM)	D1 CLEARANCE (MM)	D2 CLEARANCE (MM)
MA25-EM0.250-055	M0851	25	0.250	55	25	25
MA25-EM0.312-055	M0852	25	0.312	55	25	28
MA25-EM0.375-060	M0853	25	0.375	60	25	35
MA32-EM0.250-055	M0951	32	0.250	55	32	25
MA32-EM0.312-055	M0952	32	0.312	55	32	28
MA32-EM0.375-060	M0953	32	0.375	60	32	35
MA32-EM0.500-065	M0954	32	0.500	65	32	42
MA40-EM0.250-055	M1051	40	0.250	55	40	25
MA40-EM0.312-055	M1052	40	0.312	55	40	28
MA40-EM0.375-060	M1053	40	0.375	60	40	35
MA40-EM0.500-065	M1054	40	0.500	65	40	42
MA40-EM0.625-070	M1055	40	0.625	70	40	48
MA50-EM0.250-055	M1151	50	0.250	55	50	25
MA50-EM0.312-055	M1152	50	0.312	55	50	28
MA50-EM0.375-060	M1153	50	0.375	60	50	35
MA50-EM0.500-065	M1154	50	0.500	65	50	42
MA50-EM0.625-070	M1155	50	0.625	70	50	48
MA50-EM0.750-075	M1156	50	0.750	75	50	52
MA50-EM1.000-075	M1157	50	1.000	75	50	65
MA63-EM0.250-055	M1251	63	0.250	55	63	25
MA63-EM0.312-055	M1252	63	0.312	55	63	28
MA63-EM0.375-060	M1253	63	0.375	60	63	35
MA63-EM0.500-065	M1254	63	0.500	65	63	42
MA63-EM0.625-070	M1255	63	0.625	70	63	48
MA63-EM0.750-075	M1256	63	0.750	75	63	52
MA63-EM1.000-080	M1257	63	1.000	80	63	65
MA80-EM0.500-065	M1354	80	0.500	65	80	42
MA80-EM0.625-070	M1355	80	0.625	70	80	48
MA80-EM0.750-075	M1356	80	0.750	75	80	52
MA80-EM1.000-080	M1357	80	1.000	80	80	65
MA80-EM1.250-090	M1358	80	1.250	90	80	72

MODULAR TOOLHOLDERS



COLLET SETS

Single Angle Collet Sets

COLLET SERIES	SIZES	PART NUMBER
TG 100	3/8-1 x 16ths	STG10-111
	1/8-1 x 16ths	STG10-115
	3/8-1 x 32nds	STG10-121
	3/32-1 x 32nds	STG10-130
	3/8-1 x 64ths	STG10-141
TG 150	3/32-1 x 64ths	STG10-159
	3/4-1-1/2 x 16ths	STG15-113
	1/2-1-1/2 x 16ths	STG15-117
	3/4-1-1/2 x 32nds	STG15-125
	1/2-1-1/2 x 32nds	STG15-133
	3/4-1-1/2 x 64ths	STG15-149
	1/2-1-1/2 x 64ths	STG15-165

Double Angle Collet Sets

COLLET SERIES	SIZES	PART NUMBER
DA 300	1/16-1/4 x 32nds	SDA30-107
	3/64-1/4 x 64ths	SDA30-114
DA 200	1/8-3/8 x 32nds	SDA20-109
	1/16-3/8 x 64ths	SDA20-121
DA 100	1/8-3/8 x 64ths	SDA20-117
	1/8-7/16 x 16ths	SDA10-108
	1/4-9/16 x 64ths	SDA10-121
	1/16-9/16 x 64ths	SDA10-133
	1/8-9/16 x 32nds	SDA10-115
DA 180	1/8-9/16 x 64ths	SDA10-129
	1/4-3/4 x 16ths	SDA18-109
	1/8-3/4 x 32nds	SDA18-121
	1/8-3/4 x 64ths	SDA18-141
	1/4-3/4 x 32nds	SDA18-117
	1/4-3/4 x 64ths	SDA18-133

ER Collet Sets

COLLET SERIES	SIZES	PART NUMBER
ER 16	(0.020 - 0.393) x 0.040	SER16-040
ER 20	(0.040 - 0.511) x 0.040	SER20-040
ER 32	(0.080 - 0.787) x 0.040	SER32-040

Sealed ER Coolant Collet Sets

COLLET SERIES	SIZES	PART NUMBER
ER 16	(0.120 - 0.393) x 0.040	SER16-040C
ER 20	(0.120 - 0.511) x 0.040	SER20-040C
ER 32	(0.120 - 0.787) x 0.040	SER32-040C

• All collet sets include wooden tray

SEALED ER COOLANT STYLE COLLETS

A revolutionary high precision front sealing collet with 0.04" collapsibility that will turn any collet chuck into a coolant-fed tool for high pressure coolant supply up to 1338 P.S.I.

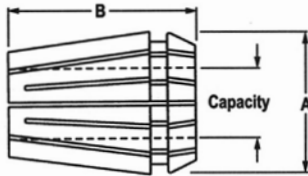

COLLET	A	B	COLLET CAPACITY
ER16	0.669	1.062	0.020-0.393
ER20	0.826	1.220	0.040-0.511
ER32	1.299	1.574	0.080-0.787

CAPACITY			ER 16 PART NUMBER	ER 20 PART NUMBER	ER 32 PART NUMBER
INCH	DECIMAL	MM RANGE			
1/8	(0.120 - 0.160)	4.0-3.0	ER16-040C	ER20-040C	ER32-040C
3/16	(0.160 - 0.200)	5.0-4.0	ER16-050C	ER20-050C	ER32-050C
7/32	(0.200 - 0.236)	6.0-5.0	ER16-060C	ER20-060C	ER32-060C
1/4	(0.236 - 0.275)	7.0-6.0	ER16-070C	ER20-070C	ER32-070C
5/16	(0.275 - 0.315)	8.0-7.0	ER16-080C	ER20-080C	ER32-080C
11/32	(0.315 - 0.354)	9.0-8.0	ER16-090C	ER20-090C	ER32-090C
3/8	(0.354 - 0.393)	10.0-9.0	ER16-100C	ER20-100C	ER32-100C
13/32	(0.393 - 0.433)	11.0-10.0	-	ER20-110C	ER32-110C
7/16	(0.433 - 0.472)	12.0-11.0	-	ER20-120C	ER32-120C
1/2	(0.472 - 0.511)	13.0-12.0	-	ER20-130C	ER32-130C
17/32	(0.511 - 0.551)	14.0-13.0	-	-	ER32-140C
9/16	(0.551 - 0.590)	15.0-14.0	-	-	ER32-150C
5/8	(0.590 - 0.629)	16.0-15.0	-	-	ER32-160C
21/32	(0.629 - 0.669)	17.0-16.0	-	-	ER32-170C
11/16	(0.669 - 0.708)	18.0-17.0	-	-	ER32-180C
3/4	(0.708 - 0.750)	19.0-18.0	-	-	ER32-190C
25/32	(0.750 - 0.787)	20.0-19.0	-	-	ER32-200C



Visit our website at www.coolantfedtooling.com for technical information and our latest product offerings.



ER STYLE COLLETS

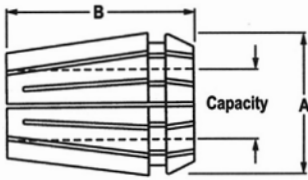

COLLET	A	B	COLLET CAPACITY
ER16	0.669	1.062	0.020-0.393
ER20	0.826	1.220	0.040-0.511
ER32	1.299	1.574	0.080-0.787

CAPACITY		MM RANGE	ER 16 PART NO.	ER 20 PART NO.	ER 32 PART NO.
INCH	(DECIMAL)				
1/32	(0.020 - 0.040)	1.0-0.5	ER16-010	-	-
1/16	(0.040 - 0.080)	2.0-1.0	ER16-020	ER20-020	-
3/32	(0.080 - 0.120)	3.0-2.0	ER16-030	ER20-030	ER32-030
1/8	(0.120 - 0.160)	4.0-3.0	ER16-040	ER20-040	ER32-040
3/16	(0.160 - 0.200)	5.0-4.0	ER16-050	ER20-050	ER32-050
7/32	(0.200 - 0.236)	6.0-5.0	ER16-060	ER20-060	ER32-060
1/4	(0.236 - 0.275)	7.0-6.0	ER16-070	ER20-070	ER32-070
5/16	(0.275 - 0.315)	8.0-7.0	ER16-080	ER20-080	ER32-080
11/32	(0.315 - 0.354)	9.0-8.0	ER16-090	ER20-090	ER32-090
3/8	(0.354 - 0.393)	10.0-9.0	ER16-100	ER20-100	ER32-100
13/32	(0.393 - 0.433)	11.0-10.0	-	ER20-110	ER32-110
7/16	(0.433 - 0.472)	12.0-11.0	-	ER20-120	ER32-120
1/2	(0.472 - 0.511)	13.0-12.0	-	ER20-130	ER32-130
17/32	(0.511 - 0.551)	14.0-13.0	-	-	ER32-140
9/16	(0.551 - 0.590)	15.0-14.0	-	-	ER32-150
5/8	(0.590 - 0.629)	16.0-15.0	-	-	ER32-160
21/32	(0.629 - 0.669)	17.0-16.0	-	-	ER32-170
11/16	(0.669 - 0.708)	18.0-17.0	-	-	ER32-180
3/4	(0.708 - 0.750)	19.0-18.0	-	-	ER32-190
25/32	(0.750 - 0.787)	20.0-19.0	-	-	ER32-200

SINGLE ANGLE TGNP STYLE COLLETS

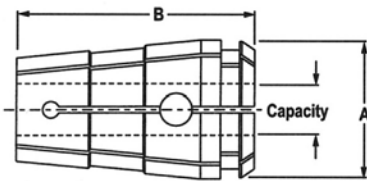

COLLET	A	B	COLLET CAPACITY
TGNP10	1.379	2.375	0.375-1.000

CAPACITY (INCHES)	DECIMAL (INCHES)	TGNP 100	
		PART NO.	OLD PART NO.
3/8	0.375	TGNP10-0375	501-024
1/2	0.500	TGNP10-0500	501-032
5/8	0.625	TGNP10-0625	501-040
3/4	0.750	TGNP10-0750	501-048
7/8	0.875	TGNP10-0875	501-056
1	1.000	TGNP10-1000	501-064

• These collets have the same features as the Single Angle TG Style Collets with the added benefit of “non-pullout” for positive drive and axial retention.



Visit our website at www.coolantfedtooling.com for technical information and our latest product offerings.



SINGLE ANGLE TG STYLE COLLETS

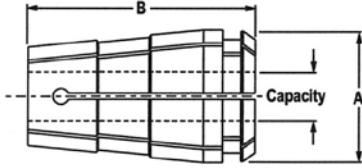

COLLET	A	B	COLLET CAPACITY
TG100	1.379	2.375	0.094-1.000
TG150	2.001	3.000	0.500-1.500



CAPACITY (INCHES)	DECIMAL (INCHES)	TG100		TG150		CAPACITY (INCHES)	DECIMAL (INCHES)	TG100		TG150	
		PART NO.	OLD PART NO.	PART NO.	OLD PART NO.			PART NO.	OLD PART NO.	PART NO.	OLD PART NO.
3/32	0.094	TG10-0094	500-006	-	-	13/16	0.812	TG10-0812	500-052	TG15-0812	550-052
7/64	0.109	TG10-0109	500-007	-	-	53/64	0.828	TG10-0828	500-053	TG15-0828	550-053
1/8	0.125	TG10-0125	500-008	-	-	27/32	0.844	TG10-0844	500-054	TG15-0844	550-054
9/64	0.141	TG10-0141	500-009	-	-	55/64	0.859	TG10-0859	500-055	TG15-0859	550-055
5/32	0.153	TG10-0156	500-010	-	-	7/8	0.875	TG10-0875	500-056	TG15-0875	550-056
11/64	0.172	TG10-0172	500-011	-	-	57/64	0.890	TG10-0891	500-057	TG15-0891	550-057
3/16	0.188	TG10-0188	500-012	-	-	29/32	0.906	TG10-0906	500-058	TG15-0906	550-058
13/64	0.203	TG10-0203	500-013	-	-	59/64	0.922	TG10-0922	500-059	TG15-0922	550-059
7/32	0.219	TG10-0219	500-014	-	-	15/16	0.937	TG10-0938	500-060	TG15-0938	550-060
15/64	0.234	TG10-0234	500-015	-	-	61/64	0.953	TG10-0953	500-061	TG15-0953	550-061
1/4	0.250	TG10-0250	500-016	-	-	31/32	0.969	TG10-0968	500-062	TG15-0968	550-062
17/64	0.266	TG10-0266	500-017	-	-	63/64	0.984	TG10-0984	500-063	TG15-0984	550-063
9/32	0.281	TG10-0281	500-018	-	-	1	1.000	TG10-1000	500-064	TG15-1000	550-064
19/64	0.297	TG10-0297	500-019	-	-	1-1/64	1.016	-	-	TG15-1016	550-065
5/16	0.312	TG10-0312	500-020	-	-	1-1/32	1.031	-	-	TG15-1031	550-066
21/64	0.328	TG10-0328	500-021	-	-	1-3/64	1.469	-	-	TG15-1047	550-067
11/32	0.344	TG10-0344	500-022	-	-	1-1/16	1.062	-	-	TG15-1062	550-068
23/64	0.359	TG10-0359	500-023	-	-	1-5/64	1.078	-	-	TG15-1078	550-069
3/8	0.375	TG10-0375	500-024	-	-	1-3/32	1.094	-	-	TG15-1094	550-070
25/64	0.391	TG10-0391	500-025	-	-	1-7/64	1.106	-	-	TG15-1109	550-071
13/32	0.406	TG10-0406	500-026	-	-	1-1/8	1.125	-	-	TG15-1125	550-072
27/64	0.422	TG10-0422	500-027	-	-	1-9/64	1.141	-	-	TG15-1141	550-073
7/16	0.438	TG10-0438	500-028	-	-	1-5/32	1.156	-	-	TG15-1156	550-074
29/64	0.453	TG10-0453	500-029	-	-	1-11/64	1.172	-	-	TG15-1172	550-075
15/32	0.469	TG10-0469	500-030	-	-	1-3/16	1.187	-	-	TG15-1187	550-076
31/64	0.484	TG10-0484	500-031	-	-	1-13/64	1.203	-	-	TG15-1203	550-077
1/2	0.500	TG10-0500	500-032	TG15-0500	550-032	1-7/32	1.219	-	-	TG15-1219	550-078
33/64	0.516	TG10-0516	500-033	TG15-0516	550-033	1-15/64	1.234	-	-	TG15-1234	550-079
17/32	0.531	TG10-0531	500-034	TG15-0531	550-034	1-1/4	1.250	-	-	TG15-1250	550-080
35/64	0.547	TG10-0547	500-035	TG15-0547	550-035	1-17/64	1.265	-	-	TG15-1266	550-081
9/16	0.563	TG10-0562	500-036	TG15-0562	550-036	1-9/32	1.281	-	-	TG15-1281	550-082
37/64	0.578	TG10-0578	500-037	TG15-0578	550-037	1-19/64	1.297	-	-	TG15-1297	550-083
19/32	0.594	TG10-0594	500-038	TG15-0594	550-038	1-5/16	1.312	-	-	TG15-1312	550-084
39/64	0.609	TG10-0609	500-039	TG15-0609	550-039	1-21/64	1.328	-	-	TG15-1328	550-085
5/8	0.625	TG10-0625	500-040	TG15-0625	550-040	1-11/32	1.344	-	-	TG15-1344	550-086
41/64	0.641	TG10-0641	500-041	TG15-0641	550-041	1-23/64	1.359	-	-	TG15-1359	550-087
21/32	0.656	TG10-0656	500-042	TG15-0656	550-042	1-3/8	1.375	-	-	TG15-1375	550-088
43/64	0.672	TG10-0672	500-043	TG15-0672	550-043	1-25/64	1.391	-	-	TG15-1391	550-089
11/16	0.688	TG10-0688	500-044	TG15-0688	550-044	1-13/32	1.406	-	-	TG15-1406	550-090
45/64	0.703	TG10-0703	500-045	TG15-0703	550-045	1-27/64	1.422	-	-	TG15-1422	550-091
23/32	0.719	TG10-0719	500-046	TG15-0719	550-046	1-7/16	1.438	-	-	TG15-1438	550-092
47/64	0.734	TG10-0734	500-047	TG15-0734	550-047	1-29/64	1.453	-	-	TG15-1453	550-093
3/4	0.750	TG10-0750	500-048	TG15-0750	550-048	1-15/32	1.469	-	-	TG15-1469	550-094
49/64	0.766	TG10-0766	500-049	TG15-0766	550-049	1-31/64	1.484	-	-	TG15-1484	550-095
25/32	0.781	TG10-0781	500-050	TG15-0781	550-050	1-1/2	1.500	-	-	TG15-1500	550-096
51/64	0.797	TG10-0797	500-051	TG15-0797	550-051						

- Designed to produce accurate and powerful gripping of the cutting tool
- Provides maximum rigidity, thus extending the life of your cutting tools
- Interchangeable with most manufacturer's Single Angle Collets for maximum flexibility



Visit our website at www.coolantfedtooling.com for technical information and our latest product offerings.



DOUBLE ANGLE DA STYLE COLLETS

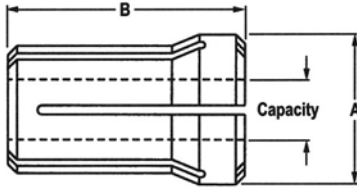

COLLET	A	B	COLLET CAPACITY
DA100	0.769	1.44	0.046-0.563
DA180	1.035	1.62	0.046-0.750
DA200	0.539	1.18	0.046-0.391
DA300	0.375	1.00	0.031-0.250



CAPACITY (INCHES)	DECIMAL (INCHES)	DA 10		DA 18		DA 20		DA 30	
		PART NO.	OLD PART NO.	PART NO.	OLD PART NO.	PART NO.	OLD PART NO.	PART NO.	OLD PART NO.
1/32	0.031	-	-	-	-	-	-	DA30-0031	539-002
3/64	0.046	DA10-0047	509-003	DA18-0047	589-003	DA20-0047	529-003	DA30-0047	539-003
1/16	0.062	DA10-0062	509-004	DA18-0062	589-004	DA20-0062	529-004	DA30-0062	539-004
5/64	0.078	DA10-0078	509-005	DA18-0078	589-005	DA20-0078	529-005	DA30-0078	539-005
3/32	0.094	DA10-0094	509-006	DA18-0094	589-006	DA20-0094	529-006	DA30-0094	539-006
7/64	0.109	DA10-0109	509-007	DA18-0109	589-007	DA20-0109	529-007	DA30-0109	539-007
1/8	0.125	DA10-0125	509-008	DA18-0125	589-008	DA20-0125	529-008	DA30-0125	539-008
9/64	0.141	DA10-0141	509-009	DA18-0141	589-009	DA20-0141	529-009	DA30-0141	539-009
5/32	0.156	DA10-0156	509-010	DA18-0156	589-010	DA20-0156	529-010	DA30-0156	539-010
11/64	0.172	DA10-0172	509-011	DA18-0172	589-011	DA20-0172	529-011	DA30-0172	539-011
3/16	0.187	DA10-0188	509-012	DA18-0188	589-012	DA20-0188	529-012	DA30-0188	539-012
13/64	0.203	DA10-0203	509-013	DA18-0203	589-013	DA20-0203	529-013	DA30-0203	539-013
7/32	0.219	DA10-0219	509-014	DA18-0219	589-014	DA20-0219	529-014	DA30-0219	539-014
15/64	0.234	DA10-0234	509-015	DA18-0234	589-015	DA20-0234	529-015	DA30-0234	539-015
1/4	0.250	DA10-0250	509-016	DA18-0250	589-016	DA20-0250	529-016	DA30-0250	539-016
17/64	0.265	DA10-0266	509-017	DA18-0266	589-017	DA20-0266	529-017	-	-
9/32	0.281	DA10-0281	509-018	DA18-0281	589-018	DA20-0281	529-018	-	-
19/64	0.297	DA10-0297	509-019	DA18-0297	589-019	DA20-0297	529-019	-	-
5/16	0.312	DA10-0312	509-020	DA18-0312	589-020	DA20-0312	529-020	-	-
21/64	0.328	DA10-0328	509-021	DA18-0328	589-021	DA20-0328	529-021	-	-
11/32	0.344	DA10-0344	509-022	DA18-0344	589-022	DA20-0344	529-022	-	-
23/64	0.359	DA10-0359	509-023	DA18-0359	589-023	DA20-0359	529-023	-	-
3/8	0.375	DA10-0375	509-024	DA18-0375	589-024	DA20-0375	529-024	-	-
25/64	0.391	DA10-0391	509-025	DA18-0391	589-025	DA20-0391	529-025	-	-
13/32	0.406	DA10-0406	509-026	DA18-0406	589-026	-	-	-	-
27/64	0.422	DA10-0422	509-027	DA18-0422	589-027	-	-	-	-
7/16	0.438	DA10-0438	509-028	DA18-0438	589-028	-	-	-	-
29/64	0.453	DA10-0453	509-029	DA18-0453	589-029	-	-	-	-
15/32	0.469	DA10-0469	509-030	DA18-0469	589-030	-	-	-	-
31/64	0.484	DA10-0484	509-031	DA18-0484	589-031	-	-	-	-
1/2	0.500	DA10-0500	509-032	DA18-0500	589-032	-	-	-	-
33/64	0.515	DA10-0516	509-033	DA18-0516	589-033	-	-	-	-
17/32	0.531	DA10-0531	509-034	DA18-0531	589-034	-	-	-	-
35/64	0.547	DA10-0547	509-035	DA18-0547	589-035	-	-	-	-
9/16	0.563	DA10-0562	509-036	DA18-0562	589-036	-	-	-	-
37/64	0.578	-	-	DA18-0578	589-037	-	-	-	-
19/32	0.594	-	-	DA18-0594	589-038	-	-	-	-
39/64	0.609	-	-	DA18-0609	589-039	-	-	-	-
5/8	0.625	-	-	DA18-0625	589-040	-	-	-	-
41/64	0.640	-	-	DA18-0641	589-041	-	-	-	-
21/32	0.656	-	-	DA18-0656	589-042	-	-	-	-
43/64	0.672	-	-	DA18-0672	589-043	-	-	-	-
11/16	0.687	-	-	DA18-0688	589-044	-	-	-	-
45/64	0.703	-	-	DA18-0703	589-045	-	-	-	-
23/32	0.719	-	-	DA18-0719	589-046	-	-	-	-
47/64	0.734	-	-	DA18-0734	589-047	-	-	-	-
3/4	0.750	-	-	DA18-0750	589-048	-	-	-	-

- Designed for flexibility over a wide range of sizes
- Interchangeable with most manufacturer's Double Angle Collets



Visit our website at www.coolantfedtooling.com for technical information and our latest product offerings.



STRAIGHT SHANK • QUICK CHANGE TENSION AND COMPRESSION TAP HOLDERS • COOLANT-THRU-THE-SPINDLE TYPE

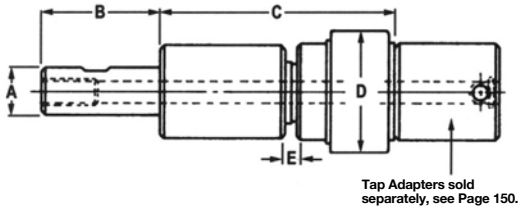

Standard Capacity #10 thru 1-3/4

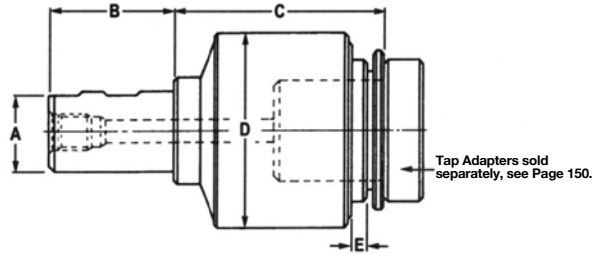

Large Capacity 3/4 thru 2-1/2

PART NUMBER	A SHANK	TAP CAPACITY	B	C PROJ.	D BODY O.D.	E TEN./COMP.	TAP ADAPTER STYLE
* 886-001N	1.25	#10 thru 1-3/4	2.50	5.00	2.450	0.560/0.120	#1 & #1A
* 886-002	2.00	3/4 thru 2-1/2	2.25	4.75	4.125	0.750/0.250	#4

*** Outgoing Items**

• These Tap Holders can normally handle up to 600 P.S.I. of actual coolant pressure without effecting tension control. Should your application exceed this limit, please consult The George Whalley Company before use.

V-FLANGE AND BT SHANK • QUICK CHANGE TENSION & COMPRESSION TAP HOLDERS • COOLANT-THRU-THE-SPINDLE TYPE

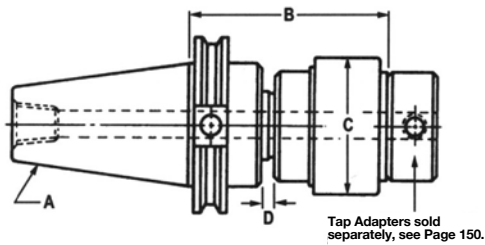

Standard Capacity #10 thru 1-3/4

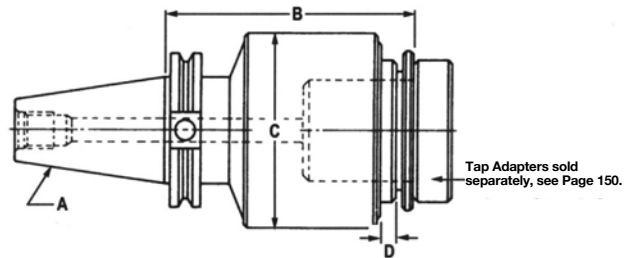

Large Capacity 3/4 thru 2-1/2

PART NUMBER	A SHANK	TAP CAPACITY	B PROJ.	C BODY O.D.	D TEN./COMP.	TAP ADAPTER STYLE
* 886-003N	40VF	#10-1-3/4	4.65	2.450	0.56/0.120	#1 & 1A
* BT886-003N	40BT	#10-1-3/4	4.77	2.450	0.56/0.120	#1 & 1A
* 886-006N	45VF	#10-1-3/4	3.84	2.450	0.56/0.120	#1 & 1A
* BT886-006N	45BT	#10-1-3/4	4.70	2.450	0.56/0.120	#1 & 1A
* 886-007N	50VF	#10-1-3/4	3.84	2.450	0.56/0.120	#1 & 1A
* BT886-007N	50BT	#10-1-3/4	3.90	2.450	0.56/0.120	#1 & 1A
* 886-004	45VF	3/4-2-1/2	5.25	4.125	0.75/0.250	#4
* 886-005	50VF	3/4-2-1/2	5.25	4.125	0.75/0.250	#4
* 886-008**	45VF	#10-1-3/8	5.75	2.310	0.56/0.120	#2 & 3

*** Outgoing Items**

** Holder has axial float on all tap sizes and torque control thru 3/4" tap size.



Visit our website at www.coolantfedtooling.com for technical information and our latest product offerings.



AUTOMOTIVE ADJUSTABLE SHANK • QUICK CHANGE TENSION AND COMPRESSION TAP HOLDERS WITH HIGH RPM COOLANT GLAND

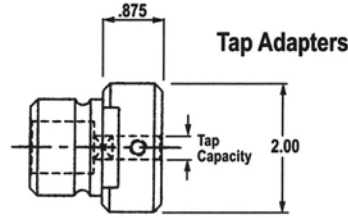
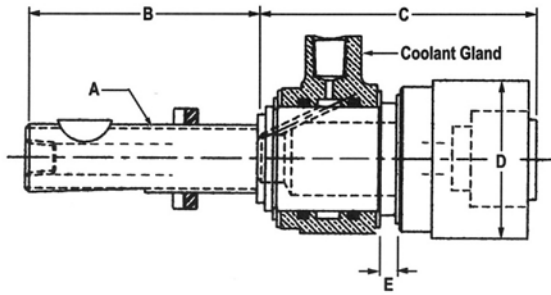

Style #1
Tap Adapters shown
on Page 150

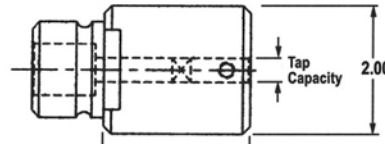

Style #1A
Tap Adapters shown
on Page 150

PART NUMBER	A SHANK	TAP CAPACITY	B	C PROJ.	D BODY DIA.	E TEN./COMP.	COOLANT GLAND
* 886-305	1-1/16-12 Acme	#10-1-3/4	3.625	6.5	2.45	0.56/0.120	CGH-2250
* 886-307	1-3/8-12 Acme	#10-1-3/4	4.750	7.0	2.45	0.56/0.120	CGH-2250

* Outgoing Items

- Dual entry design of this Tap Driver allows for use without coolant gland for coolant-thru-the-spindle operations.
- Tap Adapters sold separately, see page 150.

ROTARY INDUCER TYPE TAP HOLDERS

To retrofit non coolant-thru-the-spindle equipment for use with coolant fed taps.

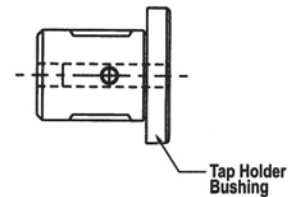
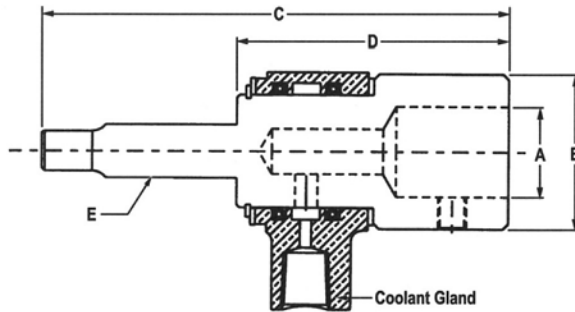

Tap Holder Bushing

PART NUMBER	A BUSHING	TAP RANGE	B	C	D	E TAP SIZE	E SHANK DIA.	COOLANT GLAND
* 873-001	5/8	#10 thru 1/8 pipe	1-1/4	4-1/2	2-1/2	5/8	0.480	CGS-0937
* 873-002	1	#10 thru 1/2 pipe	1-3/4	5.00	3.00	3/4	0.590	CGS-1250
* 873-003	1-1/4	3/8 thru 3/4 pipe	2.00	5-9/16	3.00	1-1/4	0.800	CGS-1250
* 873-004	1-1/2	1/2 thru 1" pipe	2-7/16	6-7/8	3-5/8	1-1/2	1.233	CGS-1625

* Outgoing Items

- Tap Holders are furnished with coolant glands
- Tap Holders bushings are optional, see page 151 for more information



Visit our website at www.coolantfedtooling.com for technical information and our latest product offerings.



QUICK CHANGE TAP ADAPTERS

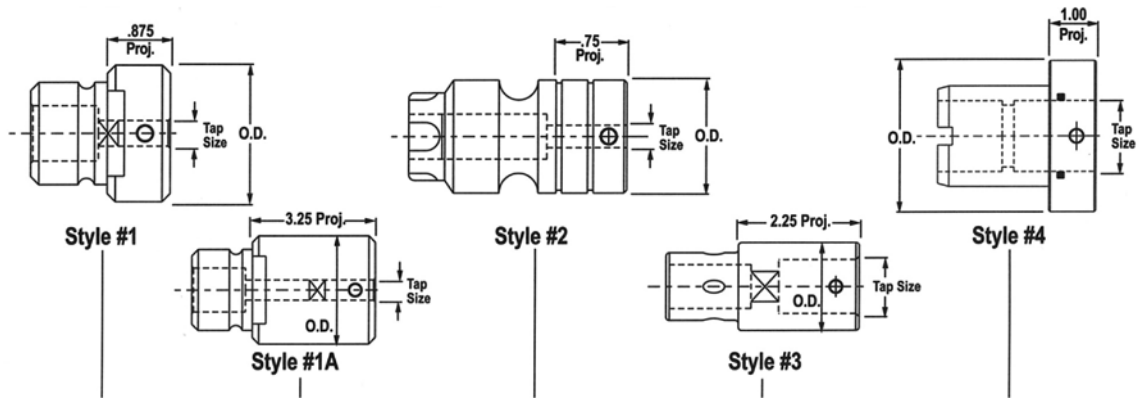

TAP SIZE	STYLE #1		STYLE #1 A		STYLE #2			STYLE #3		STYLE #4		
	PART NO.	O.D.	PART NO.	O.D.	PART NO.	O.D.	PROJ.	PART NO.	O.D.	PART NO.	O.D.	PROJ.
* #10	886-010	2.00	-	-	886-500	1.250	0.75	-	-	-	-	-
* 1/4	886-025	2.00	-	-	886-502	1.250	0.75	-	-	-	-	-
* 5/16	886-031	2.00	-	-	886-504	1.250	0.75	-	-	-	-	-
* 3/8	886-037	2.00	-	-	886-506	1.250	0.75	-	-	-	-	-
* 7/16	886-043	2.00	-	-	886-508	1.250	0.75	-	-	-	-	-
* 1/2	886-050	2.00	-	-	886-510	1.250	0.75	-	-	-	-	-
* 5/8	886-062	2.00	-	-	886-512	1.250	0.75	-	-	-	-	-
* 3/4	886-075	2.00	-	-	886-514	1.250	0.75	-	-	886-175	3.20	1.00
* 7/8	886-087	2.00	-	-	886-516	1.250	0.75	-	-	886-187	3.20	1.00
* 15/16	-	-	-	-	-	-	-	-	-	886-194	3.20	1.00
* 1	886-099	2.00	-	-	886-518	1.250	0.75	-	-	886-200	3.20	1.00
* 1-1/16-1-1/8	-	-	886-125	2.000	-	-	-	886-520	1.61	886-201	3.20	1.00
* 1-3/16-1-1/4	-	-	886-131	2.000	-	-	-	886-522	1.61	886-203	3.20	1.00
* 1-5/16-1-3/8	-	-	886-137	2.250	-	-	-	886-524	1.61	886-205	3.20	1.00
* 1-7/16-1-1/2	-	-	886-143	2.375	-	-	-	-	-	886-207	3.20	1.00
* 1-5/8	-	-	886-149	2.375	-	-	-	-	-	886-209	3.20	1.00
* 1-3/4	-	-	886-155	2.500	-	-	-	-	-	886-401	3.20	1.00
* 1-7/8	-	-	-	-	-	-	-	-	-	886-402	3.20	1.00
* 2	-	-	-	-	-	-	-	-	-	886-403	3.20	1.00
* 2-1/8	-	-	-	-	-	-	-	-	-	886-409	3.20	3.10
* 2-1/4	-	-	-	-	-	-	-	-	-	886-410	3.20	3.10
* 2-3/8	-	-	-	-	-	-	-	-	-	886-411	3.20	3.10
* 2-1/2	-	-	-	-	-	-	-	-	-	886-412	3.20	3.10
* 1/16NPT	886-106	2.00	-	-	886-526	1.250	0.75	-	-	-	-	-
* 1/8NPT	886-101	2.00	-	-	886-528	1.250	0.75	-	-	-	-	-
* 1/4NPT	886-102	2.00	-	-	886-530	1.250	0.75	-	-	-	-	-
* 3/8NPT	886-103	2.00	-	-	886-532	1.250	0.75	-	-	-	-	-
* 1/2NPT	886-104	2.00	-	-	886-534	1.250	0.75	-	-	886-408	3.20	1.00
* 3/4NPT	886-105	2.00	-	-	-	-	-	886-536	1.61	886-404	3.20	1.00
* 1NPT	-	-	886-110	2.500	-	-	-	886-538	1.61	886-405	3.20	1.00
* 1-1/4NPT	-	-	886-111	2.500	-	-	-	-	-	886-406	3.20	1.00
* 1-1/2NPT	-	-	-	-	-	-	-	-	-	886-407	3.20	1.00
* 2NPT	-	-	-	-	-	-	-	-	-	886-413	3.20	3.10

* Outgoing Items

Proj. indicates projection of tap driver from face of tapping unit

• Tap Adapters shown on this page are designed for use with specific Coolant-Thru-The-Spindle Tap Holders, shown on pages 148 and 149. Check the style indicated for your unit before ordering.



Visit our website at www.coolantfedtooling.com for technical information and our latest product offerings.



TAP HOLDER BUSHINGS FOR USE WITH ROTARY INDUCER TYPE TAP HOLDERS

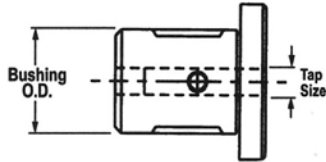

• To be used with Tap Holders shown on page 149.

TAP SIZE	BUSHING O.D.			
	5/8"	1"	1-1/4"	1-1/2"
* #10	869-001	872-001	-	-
* #12	869-002	872-002	-	-
* 1/4	869-003	872-003	-	-
* 5/16	869-004	872-004	-	-
* 3/8	869-005	872-005	874-001	-
* 7/16	869-006	872-006	874-002	-
* 1/2	869-007	872-007	874-003	875-001
* 9/16	-	872-008	874-004	875-002
* 5/8	-	872-009	874-005	875-003
* 3/4	-	872-010	874-006	875-004
* 7/8	-	-	874-007	875-005
* 1	-	-	874-008	875-006
* 1-1/8	-	-	874-009	875-007
* 1-1/4	-	-	874-010	875-008
* 1-3/8	-	-	874-011	875-009
* 1-1/2	-	-	-	875-010
* 1-5/8	-	-	-	875-011
* 1/8 Pipe S.S.	869-008	872-011	874-012	875-012
* 1/8 Pipe L.S.	-	872-012	874-013	875-013
* 1/4 Pipe	-	872-013	874-014	875-014
* 3/8 Pipe	-	872-014	874-015	875-015
* 1/2 Pipe	-	872-015	874-016	875-016
* 3/4 Pipe	-	-	874-017	875-017
* 1 Pipe	-	-	-	875-018

*** Outgoing Items**

QUICK-TAP EXTENSIONS WITH POSITIVE TAP DRIVE

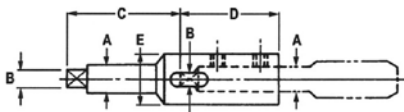

PART NUMBER	TAP SIZE	A SHANK	B TAP SQUARE	C	D	E BODY DIA.
878-101	#0-#6	0.141	0.110	2	1.00	0.44
878-102	#8	0.168	0.131	2	1.00	0.44
878-103	#10	0.194	0.152	2	1.00	0.44
878-104	1/4	0.255	0.191	2	1.12	0.62
878-105	5/16	0.318	0.238	2	1.12	0.62
878-106	3/8	0.381	0.286	2	1.25	0.75
878-107	7/16	0.323	0.242	2	1.25	0.75
878-108	1/2	0.367	0.275	2	1.25	0.75
878-109	9/16	0.429	0.322	3	1.38	0.75
878-110	5/8	0.480	0.360	3	1.62	0.88

TAPPING SYSTEMS



Visit our website at www.coolantfedtooling.com for technical information and our latest product offerings.



V-FLANGE RIGID TAP HOLDERS • BILZ STYLE • NON COOLANT-FED

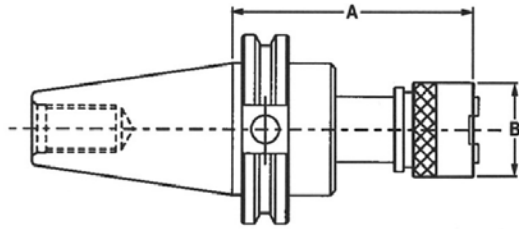

- Utilizes popular Bilz style quick change collet system
- Tap and tap size may be changed in seconds
- Precision ground components provide smooth action
- Extended lengths available upon request
- Made in the U.S.A.
- See pages 154 and 155 for Tap Adapter information

PART NUMBER	ADAPT SIZE	A PROJ.	B DIA.
* C40-RT1-275	# 1	2.75	1.25
* C40-RT2-356	# 2	3.56	1.96
* C50-RT1 -275	# 1	2.75	1.25
* C50-RT2-356	# 2	3.56	1.96
* C50-RT3-488	# 3	4.88	2.83

* **Outgoing Items**

V-FLANGE TENSION & COMPRESSION TAP HOLDERS • BILZ STYLE • NON COOLANT-FED

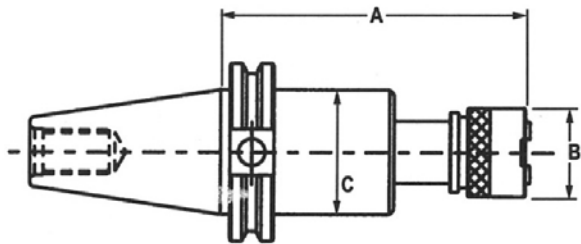

PART NUMBER	ADAPTER SIZE	TAP SIZE RANGE	A PROJ.	B DIA.	C DIA.
* C40-TC1-425	# 1	0 to 9/16 HT 1/8 PT	4.25	1.25	2.25
* C40-TC2-563	# 2	0 to 7/8 HT 1/8-1/2 PT	5.63	1.96	2.00
* C50-TC1-400	# 1	0 to 9/16 HT 1/8 PT	4.00	1.25	2.75
* C50-TC2-475	# 2	0 to 7/8 HT 1/8 to 1/2 PT	4.75	1.96	2.75
* C50-TC3-619	# 3	13/16 to 1-3/8 HT 3/4 to 1PT	6.19	2.83	2.75

* **Outgoing Items**

- Quick change -push back on the holder sleeve and the adapter with tool is removable
- Press on the end of the adapter nose and the tool is removable -all in a few seconds
- Smooth stroke-even under full torque load, the tension-compression stroke is full and free
- Interchangeability -our adapter and holders are interchangeable with Universal -Bilz quick change holders and adapters
- See pages 154 and 155 for Tap Adapter information



Visit our website at www.coolantfedtooling.com for technical information and our latest product offerings.



BT RIGID TOOLING TAP HOLDERS • BILZ STYLE • NON COOLANT-FED

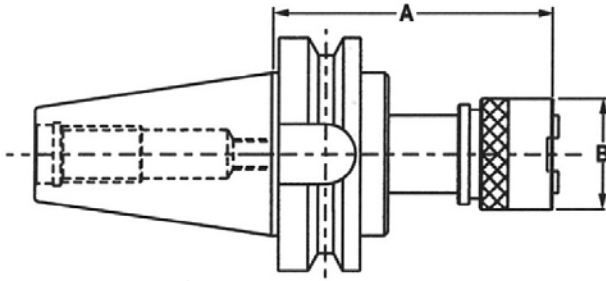

- Utilizes popular Bilz style quick change collet system
- Tap and tap size may be changed in seconds
- Precision ground components provide smooth action
- Extended lengths available upon request
- Made in the U.S.A.
- See pages 154 and 155 for Tap Adapter information

A PART NUMBER	ADAPT SIZE	A PROJ.	B DIA.
* BT40-RT1-275	# 1	2.75	1.25
* BT40-RT2-356	# 2	3.56	1.96
* BT50-RT1-288	# 1	2.88	1.25
* BT50-RT2-369	# 2	3.69	1.96
* BT50-RT3-500	# 3	5.00	2.83

* **Outgoing Items**

BT TENSION & COMPRESSION TAP HOLDERS • BILZ STYLE • NON COOLANT-FED

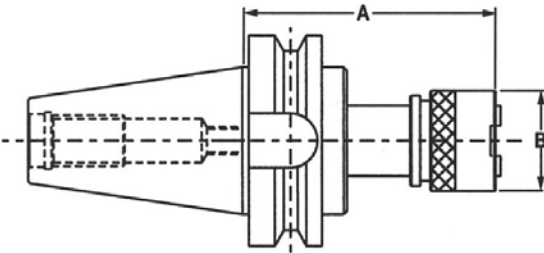

0.88 Tension / 0.38 Compression

PART NUMBER	ADAPTER SIZE	TAP SIZE RANGE	A PROJ.	B DIA.
* BT40-TC1-488	#1	0-9/16 HT to 1/8 PT	4.88	1.25
* BT40-TC2-562	#2	0-7/8 HT to 1/8-1/2 PT	5.62	1.96
* BT50-TC1-475	#1	0-9/16 HT to 1/8 PT	4.75	1.25
* BT50-TC2-550	#2	0-7/8 HT to 1/8-1/2 PT	5.50	1.96
* BT50-TC3-694	#3	13/16 - 1-3/8 HT to 3/4 to 1 PT	6.94	2.83

* **Outgoing Items**

- Quick change -push back on the holder sleeve and the adapter with tool is removable
- Press on the end of the adapter nose and the tool is removable -all in a few seconds
- Smooth stroke-even under full torque load, the tens compression stroke is full and free
- Interchangeability -our adapter and holders are interchangeable with Universal -Bilz quick change holders and adapters
- See pages 154 and 155 for Tap Adapter information



Visit our website at www.coolantfedtooling.com for technical information and our latest product offerings.



BILZ STYLE • TAP ADAPTERS

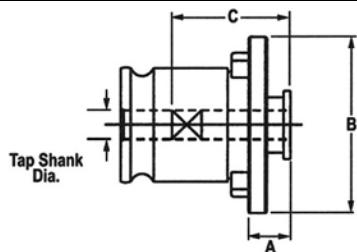

ADAPTER SIZE	TAP RANGE	PART NUMBER	TAP SIZE	SHANK SIZE	A PROJ.	B DIA.	C DEPTH
#1	0" to 9/16" HAND TAP	* 81-#0-6	0-6	0.141	0.28	1.18	0.85
		* 81-#8	8	0.168	0.28	1.18	0.92
		* 81-#10	10	0.194	0.28	1.18	0.92
		* 81-#12	12	0.220	0.28	1.18	0.95
		* 81-025	14 & 1/4	0.255	0.28	1.18	0.95
		* 81-031	5/16	0.318	0.28	1.18	0.98
		* 81-037	3/8 LS	0.381	0.28	1.18	1.05
		* 81-043	7/16	0.323	0.28	1.18	1.06
		* 81-050	1/2	0.367	0.28	1.18	1.11
		* 81-056	9/16	0.429	0.28	1.18	1.17
	1/8" SS & LS PIPE TAP	* 81-012PSS	1/8 PSS	0.313	0.28	1.18	1.05
* 81-012PLS		1/8 PLS	0.437	0.28	1.18	1.05	
#2	0" TO 7/8" HAND TAP	* 82-#0-6	0-6	0.141	0.32	1.88	0.85
		* 82-#8	8	0.168	0.32	1.88	0.92
		* 82-#10	10	0.194	0.32	1.88	0.92
		* 82-#12	12	0.220	0.32	1.88	0.95
		* 82-025	14 & 1/4	0.255	0.32	1.88	0.95
		* 82-031	5/16	0.318	0.43	1.88	1.49
		* 82-037	3/8 LS	0.381	0.43	1.88	1.56
		* 82-043	7/16	0.323	0.43	1.88	1.59
		* 82-050	1/2	0.367	0.43	1.88	1.62
		* 82-056	9/16	0.429	0.43	1.88	1.68
		* 82-062	5/8	0.480	0.43	1.88	1.74
		* 82-068	11/16	0.542	0.43	1.88	1.81
		* 82-075	3/4	0.590	0.43	1.88	1.87
		* 82-081	13/16	0.652	0.43	1.88	1.87
	* 82-087	7/8	0.697	0.43	1.88	1.93	
	1/8" SS & LS 1/4" to 1/2" PIPE TAP	* 82-012PSS	1/8 PSS	0.313	0.35	1.88	1.49
		* 82-012PLS	1/8 PLS	0.437	0.35	1.88	1.05
		* 82-025P	1/4P	0.562	0.35	1.88	1.18
* 82-037P		3/8P	0.700	0.35	1.88	1.24	
		* 82-050P	1/2P	0.687	0.35	1.88	1.37
#3	13/16" to 1-3/8" HAND TAP	* 83-081	13/16	0.652	0.55	2.75	2.42
		* 83-087	7/8	0.697	0.55	2.75	2.48
		* 83-093	15/16	0.760	0.55	2.75	2.48
		* 83-1000	1	0.800	0.55	2.75	2.54
		* 83-1012	1-1/8	0.896	0.55	2.75	2.61
		* 83-1025	1-1/4	1.021	0.55	2.75	2.73
		* 83-1037	1-3/8	1.108	0.55	2.75	2.79
	3/4" to 1" PIPE TAP	* 83-075P	3/4P	0.906	0.43	2.75	1.55
		* 83-1000P	1P	1.125	0.43	2.75	1.68

*** Outgoing Items**

• Tap Adapters shown on this page are designed for use with Tap Holders shown on pages 152 and 153.



Visit our website at www.coolantfedtooling.com for technical information and our latest product offerings.



BILZ STYLE • TORQUE CONTROL • TAP ADAPTERS

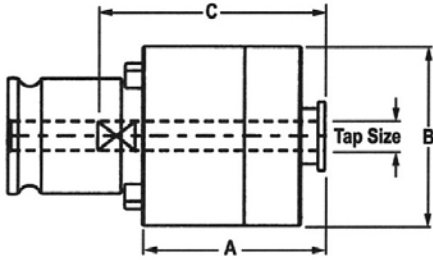

ADAPTER SIZE	TAP RANGE	PART NUMBER	TAP SIZE	A PROJ.	B DIA.	C DEPTH	TORQUE FT. LBS.
#1	0" to 9/16" HAND TAP	* 91-#0-6	0-6	0.98	1.26	0.85	1.1
		* 91-#8	8	0.98	1.26	0.92	1.7
		* 91-#10	10	0.98	1.26	0.92	2.2
		* 91-#12	12	0.98	1.26	0.95	2.5
		* 91-025	1/4	0.98	1.26	0.95	4.3
		* 91-031	5/16	0.98	1.26	0.98	7.2
		* 91-037	3/8	0.98	1.26	1.05	10.8
		* 91-043	7/16	0.98	1.26	1.08	17.0
		* 91-050	1/2	0.98	1.26	1.11	25.0
		* 91-056	9/16	0.98	1.26	1.06	29.0
	1/8" PIPE TAP	* 91-012PSS	1/8 SS	0.98	1.26	1.05	29.0
* 91-012PLS		1/8 LS	0.98	1.26	1.05	7.0	
#2	5/16" to 7/8" HAND TAP	* 92-031	5/16	1.34	1.97	1.49	7.2
		* 92-037	3/8	1.34	1.97	1.56	10.8
		* 92-043	7/16	1.34	1.97	1.59	17.0
		* 92-050	1/2	1.34	1.97	1.62	25.0
		* 92-056	9/16	1.34	1.97	1.68	29.0
		* 92-062	5/8	1.34	1.97	1.74	36.0
		* 92-068	11/16	1.34	1.97	1.81	40.0
		* 92-068	11/16	1.34	1.97	1.81	40.0
		* 92-075	3/4	1.34	1.97	1.87	53.0
		* 92-081	13/16	1.34	1.97	1.87	57.0
	1/4" to 1/2" PIPE TAP	* 92-087	7/8	1.34	1.97	1.93	69.0
		* 92-025P	1/4P	1.34	1.97	1.18	11.0
		* 92-037P	3/8P	1.34	1.97	1.24	14.0
		* 92-050P	1/2P	1.34	1.97	1.37	32.0
#3	13/16" to 1-3/8" HAND TAP	* 93-081	13/16	1.77	2.83	2.42	57.0
		* 93-087	7/8	1.77	2.83	2.48	69.0
		* 93-093	15/16	1.77	2.83	2.48	76.0
		* 93-1000	1	1.77	2.83	2.54	94.0
		* 93-1012	1-1/8	1.77	2.83	2.61	126.0
		* 93-1025	1-1/4	1.77	2.83	2.73	144.0
		* 93-1037	1-3/8	1.77	2.83	2.79	188.0
		1/2" to 1" PIPE TAP	* 93-050P	1/2P	1.77	2.83	1.55
	* 93-075P		3/4P	1.77	2.83	1.55	42.0
	* 93-1000P		1P	1.77	2.83	1.68	81.0

* Outgoing Items

• Tap Adapters shown on this page are designed for use with Tap Holders shown on pages 152 and 153.



Visit our website at www.coolantfedtooling.com for technical information and our latest product offerings.

TAPPING SYSTEMS



SOLID STEEL STOP SCREW

Note: When coolant-thru-the-tool is not necessary, these screws can also be used as a standard Backup or Adjusting Screw

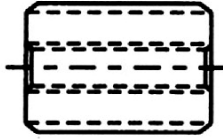

PART NUMBER	OLD PART NO.	THREAD SIZE
101-001	855-001	3/4-16 L.H.
101-002	855-002	13/16-16 L.H.
101-003	855-003	1-1/8-16 L.H.
101-004	855-004	1-1/4-12 L.H.
101-005	855-005	7/16-20 L.H.
101-006	855-006	5/8-18 L.H.
101-007	855-007	1-5/8-12 L.H.
101-008	855-008	1-3/8-12 L.H.
101-009	855-009	7/8-14 L.H.
101-010	855-010	15/16-16 L.H.
101-011	855-012	3/8-24 L.H.

PART NUMBER	OLD PART NO.	THREAD SIZE
101-012	855-013	9/16-18 L.H.
101-013	-	1-3/8-16 L.H.
101-014	-	1-5/8-16 L.H.
101-015	-	1-1/4-16 L.H.
101-016	-	7/16-16 L.H.
101-017	-	5/8-16 L.H.
101-018	-	9/16-16 L.H.
101-019	-	7/8-16 L.H.
101-020	-	11/16-16 L.H.
101-021	-	1/2-16 L.H.

ER SOLID STEEL COOLANT STYLE STOP SCREW

Note: When coolant-thru-the-tool is not necessary, these screws can also be used as a standard Backup or Adjusting Screw

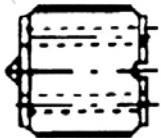

PART NUMBER	OLD PART NO.	THREAD SIZE
101-023	-	M12 x 1.75
101-024	-	M12 x 1.50
* 101-025	-	M12 x 1.75

PART NUMBER	OLD PART NO.	THREAD SIZE
* 101-026	-	M12 x 1.5
* 101-027	-	M12 x 2.0
* 101-028	-	M12 x 2.0

* Non-Coolant Solid

NYLON CAP STOP SCREW

Note: These screws are steel with a nylon cap to seal against the end of a recessed drill.

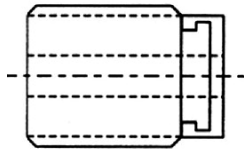

PART NUMBER	OLD PART NO.	THREAD SIZE
102-001	851-001	3/4-16 L.H.
102-002	851-002	13/16-16 L.H.
102-003	851-003	1-1/8-16 L.H.
102-004	851-004	1-1/4-12 L.H.
102-005	851-005	7/16-20 L.H.
102-006	851-006	5/8-18 L.H.

PART NUMBER	OLD PART NO.	THREAD SIZE
102-007	851-007	1-5/8-12 L.H.
102-008	851-008	1-3/8-12 L.H.
102-009	851-009	7/8-14 L.H.
102-010	851-010	15/16-16 L.H.
102-011	851-012	3/8-24 L.H.
102-012	851-013	9/16-18 L.H.

SOLID NYLON STOP SCREW

Note: These screws are solid teflon designed for leak-proof sealing of threads whenever minimum in and out adjustment is necessary.

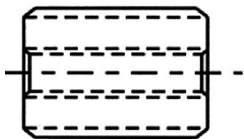

PART NUMBER	OLD PART NO.	THREAD SIZE
103-001	851-101	3/4-16 L.H.
103-002	851-102	13/16-16 L.H.
103-003	851-103	1-1/8-16 L.H.
103-004	851-104	1-1/4-12 L.H.
103-005	851-105	7/16-20 L.H.
103-006	851-106	5/8-18 L.H.

PART NUMBER	OLD PART NO.	THREAD SIZE
103-007	851-107	1-5/8-12 L.H.
103-008	851-108	1-3/8-12 L.H.
103-009	851-109	7/8-14 L.H.
103-010	851-110	5/16-24 L.H.
103-011	851-111	15/1-16 L.H.
103-012	851-112	3/8-24 L.H.

END MILL HOLDER COOLANT STOP SCREW

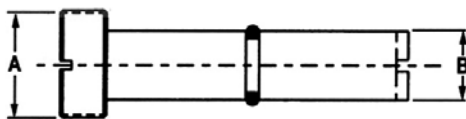

PART NO.	OLD PART NO.	(A) THREAD SIZE	B
105-001	854-001	1-1/8-12 L.H.	0.745
105-002	854-002	1-1/8-16 L.H.	0.745
105-003	854-003	3/4-10 R.H.	0.365
105-004	854-004	1-8 R.H.	0.490

PART NO.	OLD PART NO.	(A) THREAD SIZE	B
105-005	854-005	5/8-11 R.H.	0.365
105-006	854-006	M24X3 L.H.	0.490
105-007	854-008	M16X2 L.H.	0.365
105-010	-	1-8 R.H.	0.490



COOLANT SEAL ADAPTER

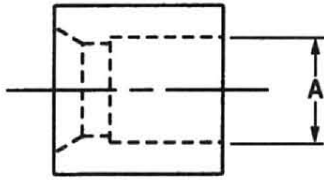

Note: These solid nylon adapters should be used for straight tools 15/64" or smaller for maximum leakage control.

PART NUMBER	OLD PART NO.	A I.D.
107-001	853-001	0.125
107-002	853-002	0.140
107-003	853-003	0.156
107-004	853-004	0.171
107-005	853-005	0.187
107-006	853-006	0.203
107-007	853-007	0.218
107-008	853-008	0.234

REAR OIL FEED ADAPTERS

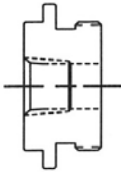

PART NUMBER	OLD PART NO.	SIZE
108-001	852-001	3/4-16 L.H.
108-002	852-002	13/16-16 L.H.
108-003	852-003	1-1/8-16 L.H.
108-004	852-004	1-1/4-12 L.H.
108-005	852-005	1-5/8-12 L.H.

EXTENDED STOP SCREW FOR USE WITH END MILLS

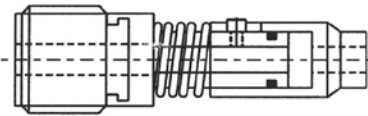

Note: This stop screw must be used in conjunction with a non-pullout end mill collet to assure proper seal.

PART NUMBER	OLD PART NO.	THREAD	END MILL RANGE
109-001	600-001	1-1/8-16 L.H.	1/2-5/8
109-002	600-002	1-1/8-16 L.H.	3/4-1
109-003	600-003	1-5/8-16 L.H.	1/2-5/8
109-004	600-004	1-5/8-16 L.H.	3/4-1
109-005	600-005	1-5/8-16 L.H.	1-1/4 -1-1/2
109-006	600-006	1-1/4-12 L.H.	1-1/4 -1-1/2
109-007	600-007	1-3/8-12 L.H.	1-1/4 -1-1/2

COOLANT-FED LATHE BUSHING

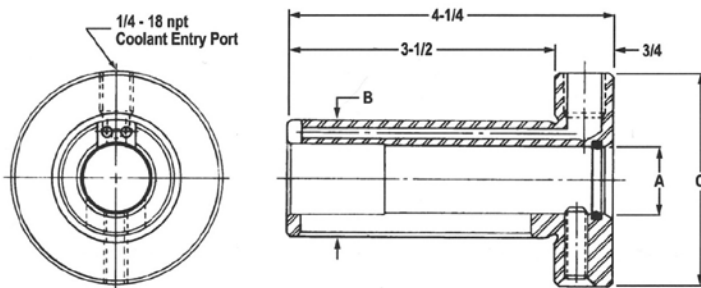

Note: These coolant-fed lathe bushings adapt easily to any lathe, allowing the use of a variety of coolant-fed tooling in machines that currently lack rear entry coolant capabilities. The coolant enters thru a coolant entry port, travels parallel to the bushing and flows to the end of the cutting tool. (Most commonly used with spade drills and indexable drills.)

PART NUMBER	A	B	C
948-005	0.750	1.4995	2-3/4
948-010	0.875	1.4995	2-3/4
948-015	1.000	2.4995	3-3/8
948-020	1.000	1.9995	3-1/8
948-025	1.250	1.9995	3-1/8
948-030	1.250	2.4995	3-3/8
948-035	1.500	1.9995	3-3/8
948-040	1.500	2.4995	3-3/8
948-045	1.750	2.4995	3-7/8
948-050	2.000	2.4995	3-7/8

PART NUMBER	A	B	C
M948-005	0.7874 (20mm)	1.2593	2-3/4
M948-010	0.7874 (20mm)	1.4995	2-3/4
M948-015	0.9842 (25mm)	1.9995	3-1/8
M948-020	0.9842 (25mm)	2.4995	3-3/8
M948-025	1.2598 (32mm)	1.9680	3-1/8
M948-030	1.2598 (32mm)	1.9995	3-1/8
M948-035	1.2598 (32mm)	2.4995	3-3/8
M948-040	1.5748 (40mm)	1.9680	3-3/8
M948-045	1.5748 (40mm)	1.9995	3-3/8
M948-050	1.5748 (40mm)	2.4995	3-3/8
M948-055	1.9685 (50mm)	2.4995	3-7/8
M948-060	0.7874 (20mm)	1.2500	2-3/4

ACCESSORIES



NYLON SEAL FOR JACOBS TAPER, DOUBLE ANGLE COLLET CHUCKS

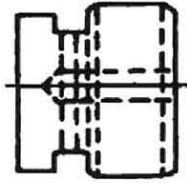

PART NUMBER	OLD PART NUMBER	DESCRIPTION
110-001	831-012	Fits JT2-DA10-CGS-2
110-002	831-013	Fits JT33-DA18-CGS-2

MORSE TAPER REDUCING SLEEVE WITH COOLANT CROSS HOLES

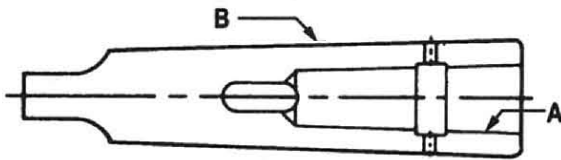

PART NUMBER	(A) INSIDE TAPER	(B) OUTSIDE TAPER
842-001	1	2
842-002	1	3
842-003	2	3
842-004	2	4
842-005	3	4
842-006	2	5
842-007	3	5
842-008	4	5

MORSE TAPER REDUCING SLEEVE WITHOUT COOLANT CROSS HOLES

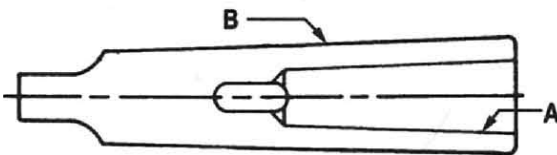

PART NUMBER	(A) INSIDE TAPER	(B) OUTSIDE TAPER
843-001	3	4
843-002	3	5
843-003	4	5

END MILL REDUCING COOLANT BUSHING

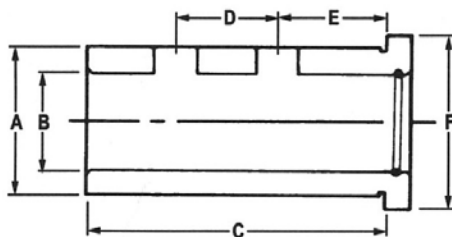

PART NUMBER	A	B	C	D	E	F
949-010	2	1-3/4	3-3/8	1-3/8	1-3/8	2-1/4
949-012	2	1-1/2	3-3/8	1-3/8	1-3/8	2-1/4
949-014	2	1-1/4	3-3/8	1-3/8	1-3/8	2-1/4
949-016	2	1.000	3-3/8	1-3/8	1-3/8	2-1/4
949-018	1-1/2	1-1/2	3	1-1/8	1	1-3/4
949-020	1-1/2	1.000	3	1-1/8	1	1-3/4
949-0787	1-1/4	0.787	3	1	1-1/8	1-5/8
949-0984	1-1/4	0.984	3	1	1-1/8	1-1/2
949-1259	1-1/2	1.259	3	1	1-1/8	2
949-1579	2	1.579	3-3/8	1-3/8	1-3/8	2-3/8
949-0748	1-1/4	0.748	3	1	1-1/8	1-1/2



DRIVE KEYS FOR SHELL MILL HOLDERS

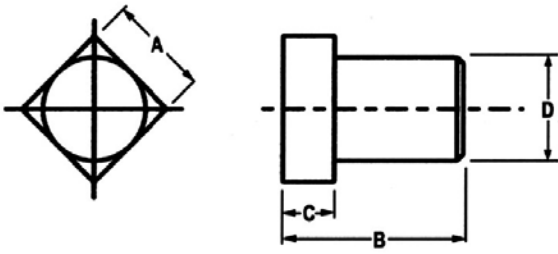

PART NUMBER	SIZE	A	B	C	D
201-001	0.500	0.250	0.50	0.12	0.2510
201-002	0.750	0.312	0.53	0.15	0.3135
201-003	1.000	0.375	0.68	0.18	0.3760
201-004	1.250	0.500	0.88	0.25	0.5010
201-005	1.500	0.625	1.06	0.31	0.6260
201-006	2.000	0.750	1.12	0.38	0.7510
201-007	2.500	1.000	1.38	0.50	1.0015

ARBOR SCREW FOR SHELL MILL HOLDERS

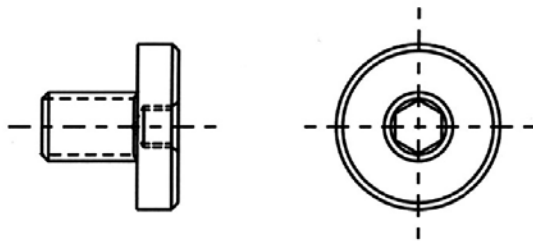

PART NUMBER	OLD PART NUMBER	PILOT DIA.	SIZE THREAD	OAL
200-001	959-001	0.50	1/4-28	0.75
200-002	959-002	0.75	3/8-24	0.94
200-003	959-003	1.00	1/2-20	1.12
* 200-004	959-103	1.00	1/2-20	1.87
200-005	959-004	1.25	5/8-18	1.25
* 200-006	959-104	1.25	5/8-18	2.00
200-007	959-005	1.50	3/4-16	1.50
* 200-008	959-105	1.50	3/4-16	2.00
200-009	959-006	2.00	1"-14	1.68
* 200-010	959-106	2.00	1"-14	2.18
200-011	959-007	2.50	1"-14 Head	3.12
* 200-012	959-107	2.50	1"-14 Head	2.18

*Note: Longer length screws needed when Coolant Style Shell Mills are used with Non-Coolant Shell Mill Adapters.

SLOTTED CAP SCREWS FOR SHELL MILL ARBORS

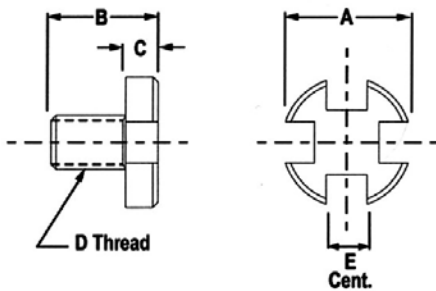

PART NUMBER	OLD PART NO.	A	B	C	D	E
113-001	959-042	0.62	0.75	0.25	1/4-28	0.38
113-002	959-043	0.88	0.94	0.31	3/8-24	0.56
113-003	959-044	1.18	1.12	0.31	1/2-20	0.88
113-004	959-045	1.50	1.25	0.31	5/8-18	0.94
113-005	959-046	1.88	1.50	0.38	3/4-16	1.18
113-006	959-047	2.50	1.68	0.38	1-14	1.68
113-007	959-048	3.12	1.68	0.38	1-14	1.68

WRENCHES FOR SLOTTED CAP SCREWS

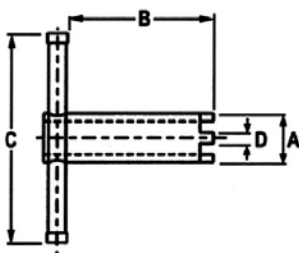

PART NUMBER	OLD PART NO.	A	B	C	D
114-001	959-049	0.62	2.25	4	0.18
114-002	959-050	0.88	2.03	5	0.25
114-003	959-051	1.18	2.18	6	0.31
114-004	959-052	1.50	2.38	7	0.38
114-005	959-053	1.88	2.50	7	0.50
114-006	959-054	2.50	2.50	7	0.62

ACCESSORIES



COMPRESSION NOSEPIECE FOR DOUBLE ANGLE COLLET CHUCKS

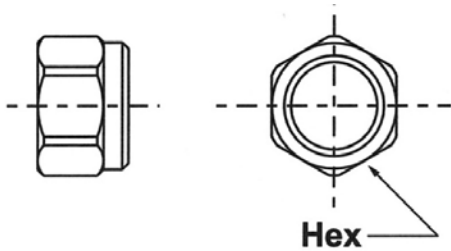

PART NUMBER	OLD PART NUMBER	SIZE
111-DA10	509-100	1-1/4 Hex
111-DA18	589-189	1-1/2 Hex

COMPRESSION NOSEPIECE FOR STRAIGHT SHANK COLLET EXTENSIONS

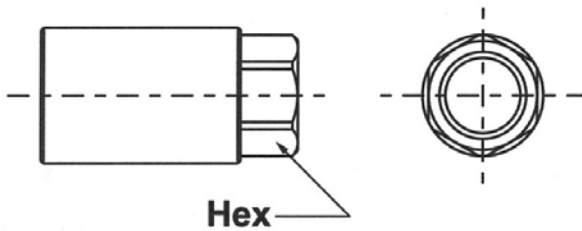

PART NUMBER	OLD PART NUMBER	SIZE
111-SDA30	961-539	1/2 Hex
111-SDA20	961-529	11/16 Hex
111-SDA10	961-509	7/8 Hex
111-SDA18	961-589	1-3/16 Hex

COMPRESSION NOSEPIECE FOR SINGLE ANGLE COLLET CHUCKS

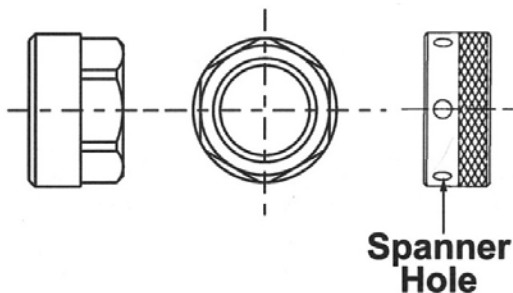

PART NUMBER	OLD PART NUMBER	SIZE
111-TG10H	500-101	2-1/4 Hex
111-TG10S	500-100	2-1/2 Spanner
111-TG15S	550-150	3-1/2 Spanner



ER CLAMPING NUT

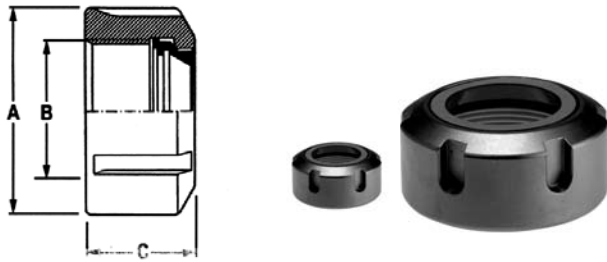

PART NUMBER	TYPE	A	B	C
115-015	ER 16	1.109	M22 X 1.5	0.672
115-016	ER 20	1.344	M25 X 1.5	0.750
115-017	ER 32	1.968	M40 X 1.5	0.875

SPANNER WRENCHES

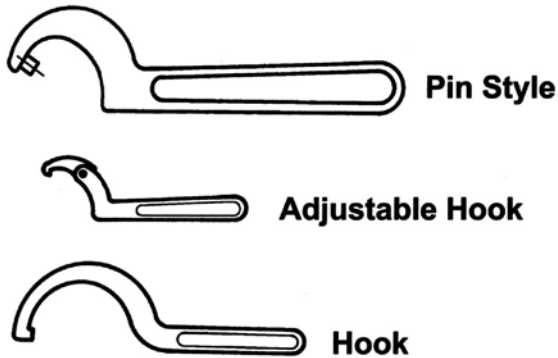

PART NUMBER	OLD PART NUMBER	SIZE	STYLE
112-001	959-458	2-1/2	Pin
112-002	959-461	3-1/4	Pin
112-003	959-472	1-1/4 to 3	Adj. Hook
112-004	959-462	4-1/2	Pin
112-010	959-471	3/4 to 2	Adj. Hook
112-011	959-474	2 to 4-1/2	Adj. Hook

ER-WRENCH

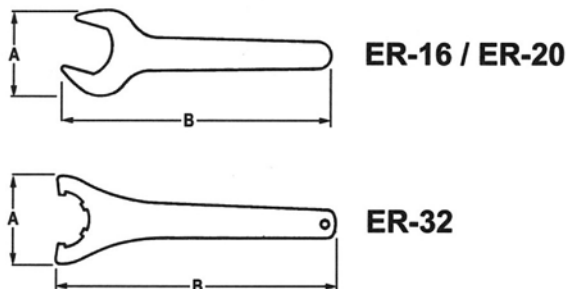

PART NUMBER	TYPE	A	B
112-102	ER 16	1.656	5.500
112-103	ER 20	2.375	5.312
112-106	ER 32	2.937	9.875

ACCESSORIES



HIGH PRESSURE AIR-OPERATED PUMPING SYSTEM • COOLANT PRESSURE UP TO 1,000 PSI/COOLANT VOLUME UP TO 10 GPM

ADAPTABLE TO MOST MACHINES/HEAVY DUTY, STAIN RESISTANT CABINET

NEW



CFT MODEL 1000

- Easy to maintain
- Small 2' x 2' footprint
- 100% guaranteed performance
- Basic System Includes:
 - Pump
 - 110V AC Solenoid
 - Standard Length Air Inlet Hose and Fittings
 - Standard Length Low Pressure Coolant Inlet Hose, Fittings, and Sump Filter
 - Standard Length High Pressure Coolant Output Hose & Fittings
 - Dual 100 Mesh and 200 Mesh Filters
- Custom Length Hoses Available on Request
- Different Voltage Solenoids Available on Request



Visit our website at www.coolantfedtooling.com for technical information and our latest product offerings.



RETENTION KNOB SOCKETS



CAUTION: Retention knobs are manufactured to the specifications of the machine tool builder and any deviation from this could cause serious problems. Retention knobs are not normally interchangeable and failure to use the correct configuration can cause the toolholder to slip from the spindle which can result in serious damage. Retention knob fractures may occur from several factors, some of which are: improper knob configuration, mis-aligned machines, metal fatigue due to use, dropped tools, over torquing etc. Unless parts are ordered to a specific drawing or catalog number, we suggest you furnish a drawing of the part, make model number and serial number of the equipment requiring the knob.

EXPANDED

RETENTION KNOB SOCKETS		
PART NUMBER	MAXIMUM FLAT (IN.)	MAXIMUM TORQUE FT-LB
•WRKS30	0.535	40
•WRKS30M	0.511	40
•WRKS30D	0.556	40
WRKS40	0.755	85
WRKS40M	0.711	85
WRKS45	1.004	100
WRKS45M	0.950	100
WRKS50	1.255	110
WRKS50M	1.185	110

• Note: WRKS30, WRKS30M and WRKS30D are 3/8" Drive Sockets

Read carefully when selecting a Socket.

LIFE TIME GUARANTEE
MADE IN THE USA
SAVES TIME
SOCKETS HAVE 1/2" DRIVE
IDEAL TIGHTNESS IS ACHIEVED

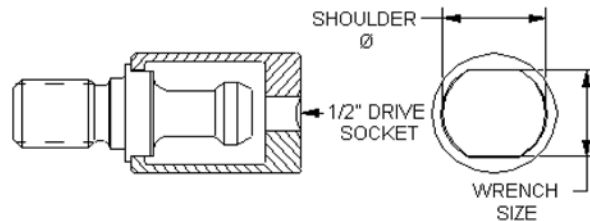

Sockets aid in the installation and removal of Retention Knobs. Ideal tightness is achieved, without rounding off the corners of the Retention Knob.

Note: Some Retention Knobs have mixed standards. Check the shoulder and Wrench Sizes carefully when selecting a Socket to fit other Retention Knobs not listed above.

RETENTION KNOBS, SPECIAL ORDERS

When ordering retention knobs not shown in the above listings, the following information is required:

1. Machine tool manufacturer
2. Model number and serial number
3. Sample retention knob (if available)
4. Drawing complete with critical dimensions as shown in the sample sketch.

Note: This sketch of a Japanese style knob can be used for reference when requesting quotations of identifying knobs, all dimension shown are critical for proper fit.

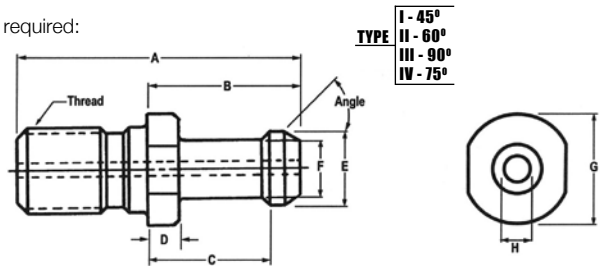

Visit our website at www.coolantfedtooling.com for technical information and our latest product offerings.

LIABILITY

Any warranty implied by law, including warranties of merchantability or fitness for a particular purpose, are hereby disclaimed and excluded. No representative or person is authorized to give any other warranty or to assume for The George Whalley Company. The George Whalley Company will not be liable for any incidental or consequential damages. The products illustrated in this catalog are protected by United States and foreign patents, patents pending, and applied for. We have attempted to publish this catalog error free, however, we recommend inspection of tool dimensions prior to use. In addition, dimensions shown reflect current manufacturing standards and The George Whalley Company reserves the right to make changes, without notice, to incorporate design improvements.

**WARNING:
CUTTING TOOLS MAY SHATTER! ALWAYS WEAR EYE PROTECTION IN THE AREA OF THEIR USE.**

ACCESSORIES



CV FLANGE RETENTION KNOBS

EXPANDED

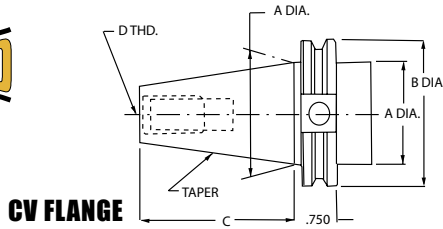

CV FLANGE SHANK DIMENSIONS

TAPER	A	B	C	D
30	1.250	1.812	1.875	1/2-13
40	1.750	2.500	2.687	5/8-11
45	2.250	3.250	3.250	3/4-10
50	2.750	3.875	4.000	1-8
60	4.250	5.500	6.375	1 1/4-7

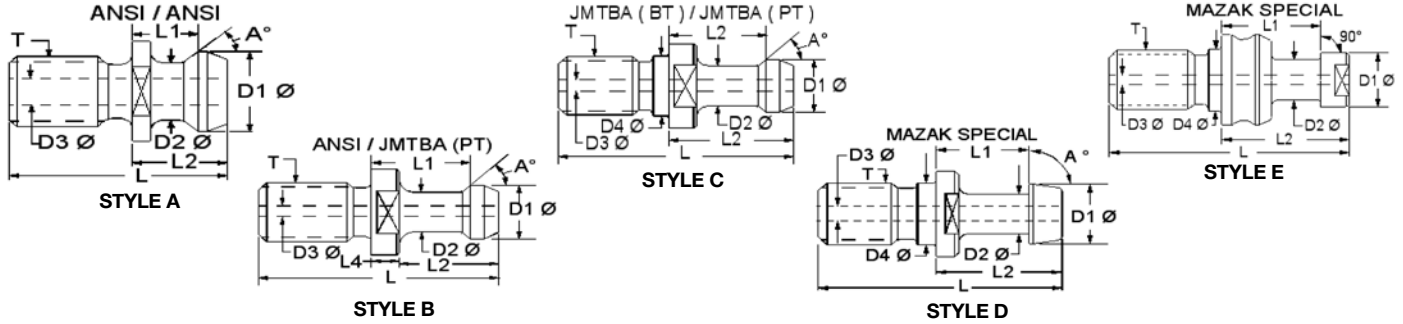

GW NO.	DESCRIPTION	STYLE	T	A	D1	D2	D3	D4	L	L1	L2	SOCKET
CV-30												
TOOL SHANK CV-30												
WRK11111	30E-A-P / A-45-.320C	H	0.500-13	45	0.5200	0.3850	0.1870	0.5120	1.2720	0.3200	0.4600	WRKS30
CV-40												
TOOL SHANK CV-40												
WRK11122	40E-A / A-45-.440(C.281)	H	0.625-11	45	0.7400	0.4900	0.2810	0.6360	1.6250	0.4400	0.6400	WRKS40
WRK11123	40E-A / A-45-.440	H	0.625-11	45	0.7400	0.4900	N/A	0.6360	1.6250	0.4400	0.6400	WRKS40
WRK11314	BOSTON DIGITAL	SPEC	0.625-11	15	0.5000	0.3100	N/A	N/A	1.5000	0.5930	0.7500	N/A
WRK12622	40E-A / PT-45-1.000	A	0.625-11	45	0.5880	0.3920	N/A	N/A	2.2650	1.0000	1.2650	WRKS40M
WRK17122	40E-A / PT-45-1.139	A	0.625-11	45	0.5940	0.4060	N/A	N/A	2.2500	1.1390	1.4380	WRKS40M
WRK17123	40E-A / PT-45-1.139(C.157)	A	0.625-11	45	0.5940	0.4060	0.1570	N/A	2.2500	1.1390	1.4380	WRKS40
WRK31114	40E-BT (A) / PT-45-.988	C	0.625-11	45	0.5890	0.3920	N/A	0.6360	2.2500	0.9880	1.2640	WRKS40
WRK31114A	40E-BT (A) / PT-60-.988	C	0.625-11	60	0.5890	0.3920	N/A	0.6360	2.2500	0.9880	1.2640	WRKS40
WRK31114B	40E-BT (A) / PT-90-.988	C	0.625-11	90	0.5890	0.3920	N/A	0.6360	2.2500	0.9880	1.2640	WRKS40
WRK31114B-P	40E-A / PT-90-.988	B	0.625-11	90	0.5890	0.3920	N/A	N/A	2.1250	0.9880	1.2640	WRKS40
WRK31222	40E-BT / SP-90-.777	D	0.625-11	90	0.5890	0.3880	N/A	0.6250	2.0370	0.7770	1.0530	WRKS40
WRK31226	40E (A) / A-45-.440(C.281)	H	0.625-11	45	0.7400	0.4900	0.2810	0.6405	1.6240	0.4400	0.6400	WRKS40
WRK31226-H	40E (A) / A-45-.440	H	0.625-11	45	0.7400	0.4900	N/A	0.6405	1.6240	0.4400	0.6400	WRKS40
WRK31514	40E-BT (A) / PT-45-.988(C.200)	C	0.625-11	45	0.5890	0.3920	0.2000	0.6360	2.2500	0.9880	1.2640	WRKS40
WRK31614	40E-A (A) / PT-45-.7066(C.079)	A	0.625-11	45	0.4310	0.2740	0.0790	N/A	1.8890	0.7066	0.9035	WRKS40
WRK31616	40E-A / I(A)-15-.792	I	0.625-11	15	0.7460	0.5490	N/A	0.6406	2.0080	0.7920	1.0280	WRKS40
WRK31617	40E-A (A)-O / I(A)-15-.792(C.236)	I	0.625-11	15	0.7460	0.5490	0.2360	0.6406	2.0080	0.7920	1.0280	WRKS40
WRK31814A	40E-BT / PT-60-.988(C.138)	C	0.625-11	60	0.5890	0.3920	0.1380	0.6360	2.2500	0.9880	1.2640	WRKS40
WRK32114	40E-A / .124 / PT-45-.988	C	0.625-11	45	0.5880	0.3920	0.6360	0.6360	2.1250	0.9880	1.2640	WRKS40
WRK32114A	40E-A / .124 / PT-60-.988	C	0.625-11	60	0.5880	0.3920	0.6360	0.6360	2.1250	0.9880	1.2640	WRKS40
WRK32114B	40E-A / .124 / PT-90-.988	C	0.625-11	90	0.5880	0.3920	0.6360	0.6360	2.1250	0.9880	1.2640	WRKS40
WRK32114-C	40E-A / .124 / PT-45-.988(C.187)	C	0.625-11	45	0.5880	0.3920	0.1870	0.6360	2.1240	0.9880	1.2640	WRKS40
WRK32130	40E-A-OP / .124 / PT-45-.988(C.187)-OID	C	0.625-11	45	0.5880	0.3920	0.1870	0.6406	2.1240	0.9880	1.2640	WRKS40
WRK32414B	40E-BT / PT-90-.707	C	0.625-11	90	0.5890	0.3920	N/A	0.6360	1.9700	0.7070	0.9840	WRKS40
* WRK32716	40E-A-OP / A-45-.440(C.160)	J	0.625-11	45	0.7400	0.4900	0.1600	0.6406	1.6240	0.4400	0.6400	WRKS40
** WRK32750	40E-A-OP / A-45-.440(C.160)	J	0.625-11	45	0.7400	0.4900	0.1600	0.6406	1.6240	0.4400	0.6400	WRKS40
WRK32751	40E-BT / PT-60-.481	H	0.625-11	60	0.5880	0.3920	N/A	0.6406	1.7320	0.4810	0.7570	WRKS40
WRK32914	40E-BT (BT) / I(A)-15-.9035(C.281)	I	0.625-11	15	0.7460	0.5490	0.2810	0.6406	2.1260	0.9035	1.1397	WRKS40
WRK35030	40E-BT(A) / PT-90-.988(C224)	C	0.625-11	90	0.5890	0.3920	0.2240	0.6406	2.2500	0.9880	1.2640	WRKS40
WRK51025	40E-I (A) / I(B)-45-.433(C281)	H	0.625-11	45	0.7400	0.5040	0.2810	0.6406	1.7579	0.4389	0.6456	WRKS40
WRK71123	40E-A / D(A)-15-.7874(C.236)	F	0.625-11	15	0.7470	0.5490	0.2360	0.6406	2.0040	0.7874	1.0240	WRKS40
WRK71125	40E-A / D(A)-15-.7874	F	0.625-11	15	0.7470	0.5490	N/A	0.6406	2.0040	0.7874	1.0240	WRKS40
WRK75022	40E-A / D(A)-15-.7874(C.236)-O	F	0.625-11	15	0.7470	0.5490	0.2360	0.6406	1.8800	0.7874	1.0240	WRKS40

* 8mm Counterbore on inside of thread stud.
 ** 6mm Counterbore on inside of thread stud.



CV FLANGE RETENTION KNOBS

EXPANDED

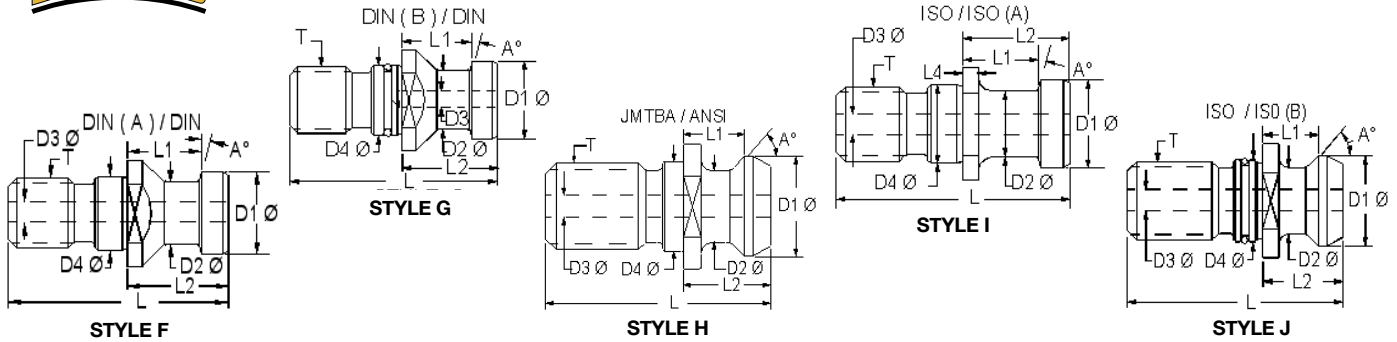

GW NO.	SMART DESCRIPTION	STYLE	T	A	D1	D2	D3	D4	L	L1	L2	SOCKET
CV-45												
TOOL SHANK CT-45												
WRK11133	45E-A / A-45-.580(C.375)	H	0.750-10	45	0.9400	0.6050	0.3750	0.7610	1.9720	0.5800	0.8200	WRKS45
WRK11135	45E-A / A-45-.580	H	0.750-10	45	0.9400	0.6050	N/A	0.7610	1.9720	0.5800	0.8200	WRKS45
¹ WRK17136	45E-A / S-90-1.000	E	0.750-10	90	0.8120	0.5620	N/A	N/A	2.1200	1.0000	1.2000	N/A
WRK31116	45E-BT / BT-45-1.228	C	0.750-10	45	0.7460	0.5490	N/A	0.7610	2.7700	1.2280	1.5830	WRKS45
WRK31116A	45E-BT / BT-60-1.228	C	0.750-10	60	0.7460	0.5490	N/A	0.7610	2.7700	1.2280	1.5830	WRKS45
WRK31116B	45E-BT / BT-90-1.228	C	0.750-10	90	0.7460	0.5490	N/A	0.7610	2.7700	1.2280	1.5830	WRKS45
WRK71134	45E-A / D(A)-15-.906(C.375)	F	0.750-10	15	0.9040	0.6670	0.3750	0.7610	2.1700	0.9055	1.1810	WRKS45M
WRK71136	45E-A / D(A)-15-.906	F	0.750-10	15	0.9040	0.6670	N/A	0.7610	2.1700	0.9055	1.1810	WRKS45M
CV-50												
TOOL SHANK CV-50												
WRK11143	50E-A / A-45-.700(C.500)	H	1.000-8	45	1.1400	0.8200	0.5000	1.0260	2.5750	0.7000	1.0000	WRKS50
WRK11144	50E-A / A-45-.700(C.468)	H	1.000-8	45	1.1400	0.8200	0.4680	1.0260	2.5750	0.7000	1.0000	WRKS50
WRK11146	50E-A / A-45-.700	H	1.000-8	45	1.1400	0.8200	N/A	1.0260	2.5750	0.7000	1.0000	WRKS50
WRK13744	50E-A / SP-40-1.025	LUCAS	1.000-8	40	0.8480	0.4980	N/A	N/A	2.9600	1.0250	1.5500	N/A
WRK17144	50E-A / A-45-.700(C.468)	A	1.000-8	45	1.1400	0.8200	0.4680	N/A	2.3000	0.7000	1.0000	WRKS50M
WRK31118	50E-BT / PT-45-1.384	C	1.000-8	45	0.9030	0.6680	N/A	1.0260	3.3500	1.3840	1.7780	WRKS50
WRK31118A	50E-BT / PT-60-1.384	C	1.000-8	60	0.9030	0.6680	N/A	1.0260	3.3500	1.3840	1.7780	WRKS50
WRK31118B	50E-BT / PT-90-1.384	C	1.000-8	90	0.9030	0.6680	N/A	1.0260	3.3500	1.3840	1.7780	WRKS50
WRK31118B-P	50E-A / PT-90-1.384	B	1.000-8	90	0.9030	0.6680	N/A	N/A	3.0800	1.3840	1.7780	WRKS50
WRK31118D	50E-A / PT-45-1.384(C.312)	C	1.000-8	45	0.9030	0.6680	0.3120	1.0260	3.0800	1.3840	1.7780	WRKS50
WRK31138A	50E-BT / PT-60-1.376	C	1.000-8	60	0.9030	0.6680	N/A	1.0260	3.3530	1.3760	1.7700	WRKS50
WRK31244A	50E-BT / M2-90-1.384	E	1.000-8	90	0.9080	0.6680	N/A	1.0260	3.3500	1.3840	1.7790	WRKSS40
WRK31246	50E-BT / A-45-.700(C.390)-OF	H	1.000-8	45	1.1400	0.8200	0.3900	1.0260	2.3000	0.7000	1.0000	WRKS50M
WRK31251A	50E-A / A-45-.700(C.390)-OID	H	1.000-8	45	1.1400	0.8200	0.3900	1.0303	2.3030	0.7000	1.0000	WRKS50M
WRK31645	50E-BT / PT-45-1.384(C.390)	C	1.000-8	45	0.9030	0.6680	0.3900	1.0260	3.3550	1.3840	1.7780	WRKS50
WRK31647	50E-BT-OP / PT-45-1.384(C.236)	C	1.000-8	45	0.9030	0.6680	0.2360	1.0260	3.3550	1.3840	1.7780	WRKS50
WRK31647H	50E-BT-OP / PT-45-1.384(C.236)-OID	C	1.000-8	45	0.9030	0.6680	0.2360	1.0260	3.3550	1.3840	1.7780	WRKS50
WRK31844A	50E-BT / PT-60-1.384(C.335)	C	1.000-8	60	0.9030	0.6680	0.3350	1.0260	3.3550	1.3840	1.7780	WRKS50
WRK32129	50E-BT-OP / PT-90-1.384(C.118)-O	C	1.000-8	90	0.9030	0.6680	0.2360	1.0260	3.3530	1.3840	1.7780	WRKS50
WRK32418B	50E-A / PT-90-903	B	1.000-8	90	0.9420	0.7060	N/A	N/A	2.5190	0.9030	1.2180	WRKS50M
WRK32419B	50E-A / PT-90-.903(C.250)	B	1.000-8	90	0.9420	0.7060	0.2500	N/A	2.5190	0.9030	1.2180	WRKS50M
WRK32420B	50E-A / PT-90-.903(C.315)	B	1.000-8	90	0.9420	0.7060	0.3150	N/A	2.5190	0.9030	1.2180	WRKS50M
WRK32749	50E-A-OP / PT-60-1.384(C.236)	C	1.000-8	60	0.9030	0.6680	0.2360	1.0232	3.3530	1.3840	1.7780	WRKS50
WRK34218B	50E-BT / PT-90-1.384(C.250)	C	1.000-8	90	0.9030	0.6680	0.2500	1.0260	3.3500	1.3840	1.7780	WRKS50
WRK51041(86)	50E-A / (A)-15-.9901	I	1.000-8	15	1.1000	0.8250	N/A	1.0301	2.9110	0.9822	1.3365	WRKS50
WRK51047	50E-A / (B)-45-.7069(C.468)	I	1.000-8	45	1.1400	0.7660	0.4680	N/A	2.5839	0.7069	1.0049	WRKS50
WRK51644	50E-A / SP-.141R-1.260	SPECIAL	1.000-8	.141R	0.7850	0.6310	N/A	N/A	2.8610	1.2659	1.5609	N/A
WRK51648	50E-A / SP-.141R-2.260	SPECIAL	1.000-8	.141R	0.7850	0.6310	N/A	N/A	3.8610	2.2659	2.5609	N/A
WRK71145	50E-A / D(A)-15-.984(C.468)	F	1.000-8	15	1.1010	0.8250	0.4680	1.0301	2.9140	0.9840	1.3380	WRKS50M
WRK71147	50E-A / D(A)-15-.984	F	1.000-8	15	1.1010	0.8250	N/A	1.0301	2.9140	0.9840	1.3380	WRKS50M
CV-60												
TOOL SHANK CV-60												
WRK11155	60E-A / A-45-1.080(C.500)	A	1.250-7	45	1.4600	1.0450	0.5000	N/A	3.2000	1.0800	1.5000	N/A

• ¹ Manufactured without Pilot.

ACCESSORIES



BT FLANGE RETENTION KNOBS

EXPANDED

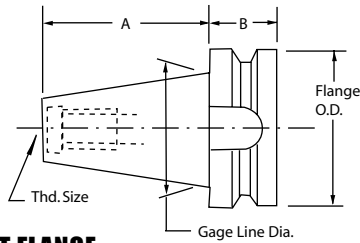

BT FLANGE

BT FLANGE SHANK DIMENSIONS

TAPER	GAGE LINE	A LG.	B LG.	FLANGE O.D.	THD. SIZE
30	1.250	1.985	0.787	1.811	M12 X 1.75
35	1.500	2.299	0.866	2.087	M12 X 1.75
40	1.750	2.654	0.984	2.480	M16 x 2.00
45	2.250	3.378	1.181	3.346	M20 x 2.50
50	2.750	4.126	1.378	3.937	M24 x 3.00

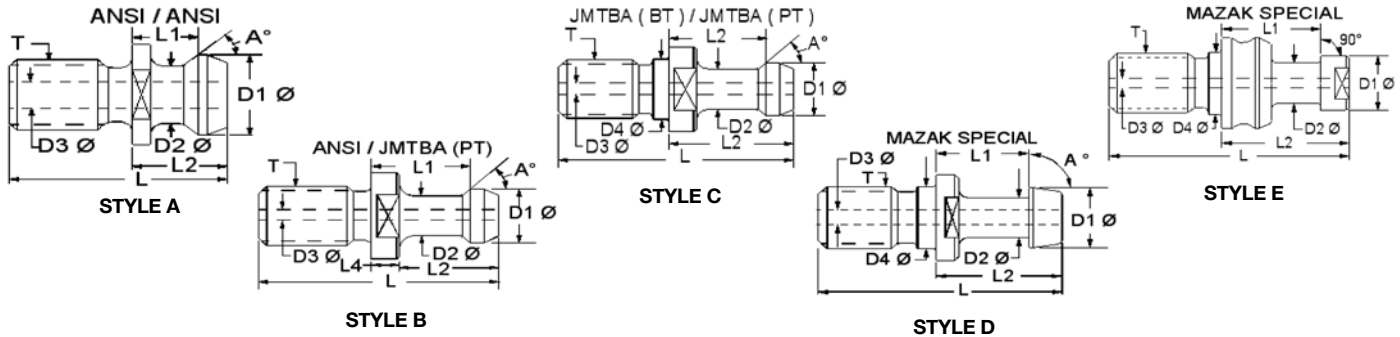

GW NO.	DESCRIPTION	STYLE	T	A	D1	D2	D3	D4	L	L1	L2	SOCKET
BT-30												
TOOL SHANK BT-30												
WRK31109	30M-BT / PT-45-.707	C	M12X1.75	45	0.4310	0.2740	N/A	0.4918	1.6900	0.7070	0.9040	WRKS30M
WRK31109A	30M-BT / PT-60-.707	C	M12X1.75	60	0.4310	0.2740	N/A	0.4918	1.6900	0.7070	0.9040	WRKS30M
WRK31109B	30M-BT / PT-90-.707	C	M12X1.75	90	0.4310	0.2740	N/A	0.4918	1.6900	0.7070	0.9040	WRKS30M
WRK31109C	30M-BT / PT-45-.707(C.110)	C	M12X1.75	45	0.4310	0.2740	0.1100	0.4918	1.6900	0.7070	0.9040	WRKS30M
WRK32621	30M-JIS / P-15-.7224(C.156)	C	M12X1.75	15	0.4720	0.3130	0.1560	0.4918	1.6930	0.7224	0.9194	WRKS30M
BT-35												
TOOL SHANK BT-35												
WRK31111	35M-BT / PT-45-.884	C	M12X1.75	45	0.5100	0.3320	N/A	0.5114	1.8870	0.8840	1.1000	N/A
WRK31111A	35M-BT / PT-60-.884	C	M12X1.75	60	0.5100	0.3330	N/A	0.5114	1.8870	0.8840	1.1000	N/A
WRK32328	35M-BT / PT-45-.634	C	M12X1.75	45	0.4080	0.3130	N/A	0.5111	1.4170	0.6340	0.7870	WRKS30D
WRK32611	35M-BT / PT-45-.884	C	M12X1.75	45	0.5380	0.3480	N/A	0.5105	2.0900	0.8840	1.1000	N/A
WRK32613	35M-BT / PT-90-.7067	C	M12X1.75	90	0.5490	0.3130	N/A	0.4918	1.7700	0.7067	0.9040	N/A
WRK32614	35M-BT / PT-60-.884	C	M12X1.75	60	0.5380	0.3480	N/A	0.4918	2.0870	0.8840	1.1000	N/A
BT-40												
TOOL SHANK BT-40												
WRK11126	40M-BT / A-45-.552	H	M16X2.00	45	0.7400	0.4900	N/A	0.6689	1.6120	0.5520	0.7520	WRKS40
WRK11126A	40M-BT / A-45-.552(C.281)	H	M16X2.00	45	0.7400	0.4900	0.281	0.6689	1.7360	0.5520	0.7520	WRKS40
WRK17126	40M-BT / PT-45-1.251	C	M16X2.00	45	0.5920	0.4040	N/A	0.6689	2.5340	1.2510	1.5500	WRKS40M
WRK17127	40M-BT / PT-45-1.251(C.141)	C	M16X2.00	45	0.5920	0.4040	0.141	0.6689	2.5340	1.2510	1.5500	WRKS40M
WRK31113	40M-BT / PT-45-1.100	C	M16X2.00	45	0.5890	0.3920	N/A	0.6690	2.3600	1.1000	1.3760	WRKS40
WRK31113A	40M-BT / PT-60-1.100	C	M16X2.00	60	0.5890	0.3920	N/A	0.6690	2.3600	1.1000	1.3760	WRKSS40
WRK31113B	40M-BT / PT-90-1.100	C	M16X2.00	90	0.5890	0.3920	N/A	0.6690	2.3600	1.1000	1.3760	WRKS40
WRK31113D	40M-BT / PT-45-1.100(C.197)	C	M16X2.00	45	0.5890	0.3920	0.197	0.6690	2.3600	1.1000	1.3760	WRKS40
WRK31113E	40M-BT / PT-60-1.100(C.197)	C	M16X2.00	60	0.5890	0.3920	0.197	0.6690	2.3600	1.1000	1.3760	WRKS40
WRK31113F	40M-BT / PT-90-1.100(C.197)	C	M16X2.00	90	0.5890	0.3920	0.197	0.6690	2.3600	1.1000	1.3760	WRKS40
WRK32912	40M-BT / I(A)-15-.9035	I	M16X2.00	15	0.7460	0.5490	N/A	0.6690	2.1260	0.9035	1.1397	WRKS40
WRK32913	40M-BT / I(A)-15-.9035(C.281)	I	M16X2.00	15	0.7460	0.5490	0.281	0.6690	2.1260	0.9035	1.1397	WRKS40
BT-45												
TOOL SHANK BT-45												
WRK31115	45M-BT / PT-45-1.218	C	M20X2.50	45	0.7460	0.5490	N/A	0.8264	2.7560	1.2180	1.5730	WRKS45M
WRK31115A	45M-BT / PT-60-1.218	C	M20X2.50	60	0.7460	0.5490	N/A	0.8264	2.7560	1.2180	1.5730	WRKS45M
WRK31115B	45M-BT / PT-90-1.218	C	M20X2.50	90	0.7460	0.5490	N/A	0.8264	2.7560	1.2180	1.5730	WRKS45M



BT FLANGE RETENTION KNOBS

EXPANDED

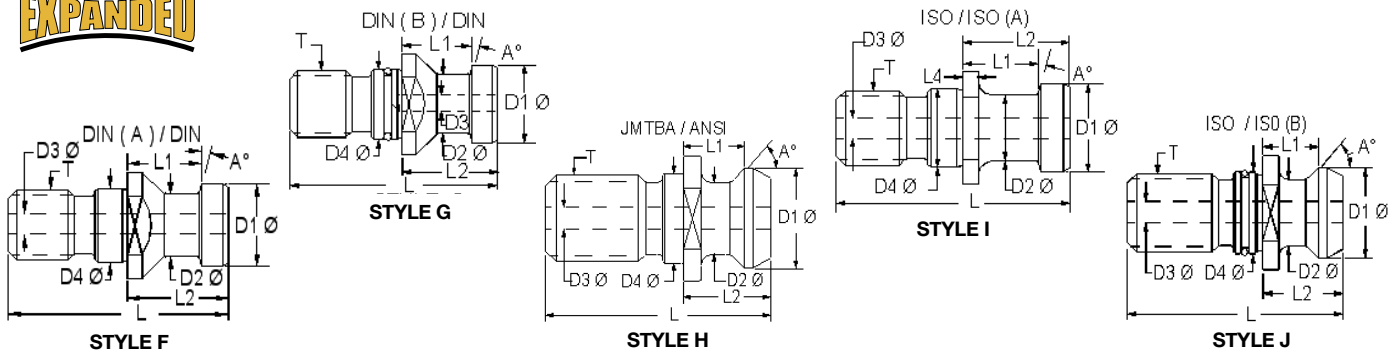

GW NO.	SMART DESCRIPTION	STYLE	T	A	D1	D2	D3	D4	L	L1	L2	SOCKET
TOOL SHANK BT-50												
WRK11144A	50M-A / A-45-.700(C.468)	H	M24X3.00	45	1.1400	0.8200	0.4680	0.9839	2.5800	0.7000	1.0000	WRKS50
WRK11148	50M-A-P / A-45-.700	H	M24X3.00	45	1.1400	0.8200	N/A	0.9839	2.5800	0.7000	1.0000	WRKS50
WRK11148A	50M-A-P / A-45-.700(C.468)	H	M24X3.00	45	1.1400	0.8200	0.4680	0.9839	2.5800	0.7000	1.0000	WRKS50
WRK31117	50M-BT / PT-45-1.376	C	M24X3.00	45	0.9030	0.6680	N/A	0.9839	3.3500	1.3760	1.7700	WRKS50M
WRK31117A	50M-BT / PT-60-1.376	C	M24X3.00	60	0.9030	0.6680	N/A	0.9839	3.3500	1.3760	1.7700	WRKS50M
WRK31117B	50M-BT / PT-90-1.376	C	M24X3.00	90	0.9030	0.6680	N/A	0.9839	3.3500	1.3760	1.7700	WRKS50M
WRK31246A	50M-A / A-45-.700(C.390)-OF	H	M24X3.00	45	1.1400	0.8200	0.3900	0.9839	2.5800	0.7000	1.0000	WRKS50M
WRK31643	50M-BT / PT-45-1.376(C.236)	C	M24X3.00	45	0.9030	0.6680	0.2360	0.9839	3.3500	1.3760	1.7700	WRKS50M
WRK31652	50M-I-O / PT-45-1.384(C.236)	C	M24X3.00	45	0.9030	0.6680	0.2360	0.9839	3.3580	1.3840	1.7780	WRKS50M
WRK31843	50M-BT / PT-60-1.376(C.312)	C	M24X3.00	60	0.9030	0.6680	0.3120	0.9839	3.3500	1.3760	1.7700	WRKS50M
WRK34217B	50M-BT / PT-90-1.376(C.250)	C	M24X3.00	90	0.9030	0.6680	0.2500	0.9839	3.3500	1.3760	1.7700	WRKS50M

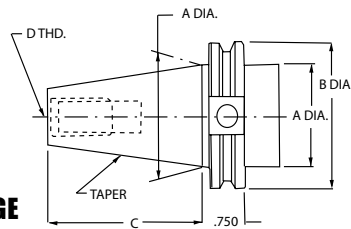

DIN / ISO FLANGE

DIN / ISO FLANGE SHANK DIMENSIONS

TAPER	A	B	C	D
30	1.250	1.967	1.876	M12 X 1.75
40	1.750	2.500	2.687	M16 X 2.00
45	2.250	3.248	3.250	M20 X 2.50
50	2.750	3.837	4.000	M24 X 3.00

GW NO.	DESCRIPTION	STYLE	T	A	D1	D2	D3	D4	L	L1	L2	SOCKET
TOOL SHANK 40												
WRK11122A	40M-BT (I) / A-45-.440(C.281)	H	M16X2.00	45	0.7400	0.4900	0.2810	0.6689	1.6240	0.4400	0.6400	WRKS40
WRK11125	40M-A (I) / A-45-.440	H	M16X2.00	45	0.7400	0.4900	N/A	0.6689	1.6240	0.4400	0.6400	WRKS40
WRK35000V	40M-BT(I) / PT-45-.988	C	M16X2.00	45	0.5890	0.3920	N/A	0.6689	2.3660	0.9880	1.2640	WRKS40
WRK35026	40M-BT(I) / PT-60-.988	C	M16X2.00	60	0.5890	0.3920	N/A	0.6689	2.3660	0.9880	1.2640	WRKS40
WRK35038	40M-BT(I) / PT-90-.988	C	M16X2.00	90	0.5890	0.3920	N/A	0.6689	2.3660	0.9880	1.2640	WRKS40
WRK51022	40M-I (I) / I(A)-15-.787(C.236)	I	M16X2.00	15	0.7460	0.5490	0.2360	0.6690	2.1250	0.7874	1.0245	WRKS40
WRK51024	40M-I / I(B)-45-.433	H	M16X2.00	15	0.7460	0.5490	N/A	0.6690	2.1250	0.7874	1.0245	WRKS40
WRK51026	40M-I (I) / I(A)-15-.787	I	M16X2.00	15	0.7460	0.5490	N/A	0.6690	2.1250	0.7874	1.0245	WRKS40
WRK71122	40M-D / D(A)-15-.787(C.236)	F	M16X2.00	15	0.7468	0.5492	0.2360	0.6682	2.1360	0.7870	1.0236	WRKS40
WRK71124	40M-D / D(A)-15-.787	F	M16X2.00	15	0.7468	0.5492	N/A	0.6680	2.1360	0.7870	1.0236	WRKS40
TOOL SHANK 45												
WRK51033	45M-I / I(A)-15-.906(C.375)	I	M20X2.50	15	0.9036	0.6673	0.3750	0.8265	2.5590	0.9055	1.1811	WRKS45
WRK51037	45M-I / I(A)-15-.906	I	M20X2.50	15	0.9036	0.6673	N/A	0.8265	2.5590	0.9055	1.1811	WRKS45
TOOL SHANK 50												
WRK35048B	50M-I / PT-90-1.384	C	M24X3.00	90	0.9030	0.6680	N/A	0.9830	3.3530	1.3840	1.7780	WRK50S
WRK71144	50M-D / D(A)-15-.984(C.468)	F	M24X3.00	15	1.1010	0.8250	0.4680	0.9830	2.9200	0.9840	1.3380	WRKS50M
WRK71146	50M-D / D(A)-15-.984	F	M24X3.00	15	1.1010	0.8250	N/A	0.9830	2.9200	0.9840	1.3380	WRKS50M

ACCESSORIES



PART NUMBER	PG.	PART NUMBER	PG.	PART NUMBER	PG.	PART NUMBER	PG.	PART NUMBER	PG.	PART NUMBER	PG.
001-801	127	109-007	157	307-031	20	601-04531	18	603-10000	22	609-04218	13
001-803	127	110-001	158	307-032	20	601-04688	18	603-10312	22	609-04375	13
001-804	127	110-002	158	307-033	20	601-04844	18	603-10625	22	609-04531	13
001-805	127	111-DA10	160	307-034	20	601-05000	18	605A-0250	14	609-04687	13
001-807	127	111-DA18	160	307-035	20	601-05156	18	605A-0375	14	609-04724	13
001-808	127	111-SDA10	160	307-036	20	601-05312	18	605A-0500	14	609-04843	13
001-811	127	111-SDA18	160	307-037	20	601-05469	18	605A-0625	14	609-04921	13
001-812	127	111-SDA20	160	307-038	20	601-05625	18	605A-0750	14	609-05000	13
001-813	127	111-SDA30	160	307-039	20	601-05781	18	605A-1000	14	710-014A	23
001-815	127	111-TG10H	160	307-040	20	601-05938	18	605B-0250	14	710-015A	23
001-817	127	111-TG10S	160	307-041	20	601-06094	18	605B-0375	14	710-016A	23
101-001	156	111-TG15S	160	325-025H	42	601-06250	18	605B-0500	14	710-017A	23
101-002	156	112-001	161	325-025M	42	601-06406	18	605B-0625	14	710-018A	23
101-003	156	112-002	161	325-045H	42	601-06562	18	605B-0750	14	710-019A	23
101-004	156	112-003	161	325-045M	42	601-06719	18	605B-1000	14	710-020A	23
101-005	156	112-004	161	325-120H	43	601-06875	18	605C-0250	14	710-021A	23
101-006	156	112-010	161	325-120M	43	601-07031	18	605C-0375	14	710-022A	23
101-007	156	112-011	161	325-140H	43	601-07188	18	605C-0500	14	710-023A	23
101-008	156	112-102	161	325-140M	43	601-07344	18	605C-0625	14	710-024A	23
101-009	156	112-103	161	331-025H	42	601-07500	18	605C-0750	14	710-025A	23
101-010	156	112-106	161	331-025M	42	601-07656	18	605C-1000	14	710-026A	23
101-011	156	113-001	159	331-045H	42	601-07821	18	605D-0250	14	710-027A	23
101-012	156	113-002	159	331-045M	42	601-07968	18	605D-0375	14	710-028A	23
101-013	156	113-003	159	331-120H	43	601-08125	18	605D-0500	14	710-029A	23
101-014	156	113-004	159	331-120M	43	601-08281	18	605D-0625	14	710-030A	23
101-015	156	113-005	159	331-140H	43	601-08438	18	605D-0750	14	710-031A	23
101-016	156	113-006	159	331-140M	43	601-08593	18	605D-1000	14	710-032A	23
101-017	156	113-007	159	337-025H	42	601-08750	18	606-029	39	710-033A	23
101-018	156	114-001	159	337-025M	42	601-08906	18	606-031	39	710-034A	23
101-019	156	114-002	159	337-045H	42	601-09062	18	606-033	39	710-035A	23
101-020	156	114-003	159	337-045M	42	601-09218	18	606-035	39	710-036A	23
101-021	156	114-004	159	337-120H	43	601-09375	18	606-037	39	710-037A	23
101-023	156	114-005	159	337-120M	43	601-09531	18	606-039	39	710-038A	23
101-024	156	114-006	159	337-140H	43	601-09687	18	606-041	39	710-039A	23
101-025	156	115-015	160	337-140M	43	601-09843	18	606-043	39	710-040A	23
101-026	156	115-016	160	343-025H	42	601-10000	18	606-045	39	710-041A	23
101-027	156	115-017	160	343-025M	42	602-01250	20	606-047	39	710-042A	23
101-028	156	116-001	111	343-045H	42	602-01406	20	606-049	39	710-043A	23
102-001	156	116-002	111	343-045M	42	602-01562	20	606-051	39	710-044A	23
102-002	156	116-003	111	343-120H	43	602-01719	20	606-053	39	710-045A	23
102-003	156	116-004	111	343-120M	43	602-01875	20	606-055	39	710-046A	23
102-004	156	117-100	81	343-140H	43	602-02031	20	606-057	39	710-047A	23
102-005	156	117-200	83	343-140M	43	602-02188	20	606-059	39	710-048A	23
102-006	156	117-300	85	350-025H	42	602-02344	20	607-013	38	710-049A	23
102-007	156	200-001	159	350-025M	42	602-02500	20	607-015	38	710-050A	23
102-008	156	200-002	159	350-045H	42	602-02656	20	607-017	38	710-051A	23
102-009	156	200-003	159	350-045M	42	602-02812	20	607-019	38	710-052A	23
102-010	156	200-004	159	350-120H	43	602-02969	20	607-021	38	710-053A	23
102-011	156	200-005	159	350-120M	43	602-03125	20	607-023	38	710-054A	23
102-012	156	200-006	159	350-140H	43	602-03281	20	607-025	38	710-055A	23
103-001	156	200-007	159	350-140M	43	602-03438	20	607-027	38	710-056A	23
103-002	156	200-008	159	356-025H	42	602-03594	20	607-029	38	710-057A	23
103-003	156	200-009	159	356-025M	42	602-03750	20	607-031	38	710-059A	23
103-004	156	200-010	159	356-045H	42	602-03906	20	607-033	38	710-060A	23
103-005	156	200-011	159	356-045M	42	602-04062	20	607-035	38	710-061A	23
103-006	156	200-012	159	356-120H	43	602-04219	20	607-037	38	710-062A	23
103-007	156	201-001	159	356-120M	43	602-04375	20	607-039	38	710-063A	23
103-008	156	201-002	159	356-140H	43	602-04531	20	607-041	38	710-064A	23
103-009	156	201-003	159	356-140M	43	602-04688	20	607-043	38	710-065A	23
103-010	156	201-004	159	3606--11	39	602-04844	20	607-045	38	710-066A	23
103-011	156	201-005	159	362-025H	42	602-05000	20	607-047	38	710-067A	23
103-012	156	201-006	159	362-025M	42	603-03125	22	607-049	38	710-068A	23
104-001	111	201-007	159	362-045H	42	603-03281	22	607-051	38	710-069A	23
104-002	111	303-001	15	362-045M	42	603-03437	22	607-053	38	710-070A	23
104-003	111	303-002	15	362-120H	43	603-03593	22	607-055	38	710-071A	23
104-004	111	303-003	15	362-120M	43	603-03750	22	607-057	38	712-014	24
104-005	111	303-004	15	362-140H	43	603-03906	22	608-021	40	712-015	24
104-006	111	303-005	15	362-140M	43	603-04062	22	608-023	40	712-016	24
104-007	111	303-006	15	375-025H	42	603-04219	22	608-025	40	712-017	24
104-008	111	303-007	15	375-025M	42	603-04375	22	608-027	40	712-018	24
104-009	111	303-008	15	375-045H	42	603-04531	22	608-029	40	712-019	24
105-001	156	303-009	15	375-045M	42	603-04688	22	608-031	40	712-020	24
105-002	156	303-010	15	375-120H	43	603-04844	22	608-033	40	712-021	24
105-003	156	303-011	15	375-120M	43	603-05000	22	608-035	40	712-022	24
105-004	156	303-012	15	375-140H	43	603-05156	22	608-037	40	712-023	24
105-005	156	307-001	20	375-140M	43	603-05312	22	608-039	40	712-024	24
105-006	156	307-002	20	387-025H	42	603-05469	22	608-041	40	712-025	24
105-007	156	307-003	20	387-025M	42	603-05625	22	608-043	40	712-026	24
105-010	156	307-004	20	387-045H	42	603-05781	22	608-045	40	712-027	24
106-001	111	307-005	20	387-045M	42	603-05938	22	608-047	40	712-028	24
106-002	111	307-006	20	387-120H	43	603-06094	22	608-049	40	712-029	24
106-003	111	307-007	20	387-120M	43	603-06250	22	608-051	40	712-030	24
106-004	111	307-008	20	387-140H	43	603-06406	22	609-01562	13	712-031	24
106-005	111	307-009	20	387-140M	43	603-06562	22	609-01575	13	712-032	24
106-006	111	307-010	20	399-025H	42	603-06719	22	609-01718	13	712-033	24
106-007	111	307-011	20	399-025M	42	603-06875	22	609-01875	13	712-034	24
107-001	157	307-012	20	399-045H	42	603-07031	22	609-02031	13	712-035	24
107-002	157	307-013	20	399-045M	42	603-07188	22	609-02165	13	712-036	24
107-003	157	307-014	20	399-120H	43	603-07344	22	609-02362	13	712-037	24
107-004	157	307-015	20	399-120M	43	603-07500	22	609-02500	13	712-038	24
107-005	157	307-016	20	399-140H	43	603-07656	22	609-02559	13	712-039	24
107-006	157	307-017	20	399-140M	43	603-07812	22	609-02656	13	712-040	24
107-007	157	307-018	20	587-100 (40V)	109	603-07968	22	609-02720	13	712-041	24
107-008	157	307-019S	20	587-101 (40V)	109	603-08125	22	609-02812	13	712-042	24
108-001	157	307-020	20	587-102 (40V)	109	603-08281	22	609-02968	13	712-044	24
108-002	157	307-021	20	587-103 (45/50V)	109	603-08437	22	609-			



PART NUMBER	PG.	PART NUMBER	PG.	PART NUMBER	PG.	PART NUMBER	PG.	PART NUMBER	PG.	PART NUMBER	PG.
712-062	24	801-040	75	802-037	28	803-055	14	805-046	17	808-013	21
712-063	24	801-041	75	802-038	28	803-056	14	805-047	17	808-014	21
712-064	24	801-043	75	802-039	28	803-057	14	805-048	17	808-015	21
712-065	24	801-044	75	802-040	28	804-001	16	805-049	17	808-016	21
712-066	24	801-045	75	802-041	28	804-002	16	805-050	17	808-017	21
712-067	24	801-046	75	802-042	28	804-003	16	805-051	17	808-018	21
712-068	24	801-047	75	802-043	28	804-004	16	805-052	17	808-019	21
712-069	24	801-048	75	802-044	28	804-005	16	805-053	17	808-020	21
712-070	24	801-049	75	802-045	28	804-006	16	805-054	17	808-021	21
712-071	24	801-050	75	802-046	28	804-007	16	805-055	17	808-022	21
718-014	25	801-051	75	802-047	28	804-008	16	805-056	17	808-023	21
718-015	25	801-052	75	802-048	28	804-009	16	805-057	17	808-024	21
718-016	25	801-053	76	802-048A	28	804-010	16	805-058	17	808-025	21
718-017	25	801-054	76	802-049	28	804-011	16	805-059	17	808-026	21
718-018	25	801-055	76	802-050	28	804-012	16	805-060	17	808-027	21
718-019	25	801-056	76	802-051	28	804-013	16	805-061	17	808-028	21
718-020	25	801-057	76	802-052	28	804-014	16	805-062	17	808-029	21
718-021	25	801-058	76	802-053	28	804-015	16	805-063	17	808-030	21
718-022	25	801-059	76	802-054	28	804-016	16	805-064	17	808-031	21
718-023	25	801-061	76	802-055	28	804-017	16	805-065	17	808-032	21
718-024	25	801-062	76	802-056	28	804-018	16	805-066	17	808-033	21
718-025	25	801-063	76	802-057	28	804-019	16	805-067	17	808-034	21
718-026	25	801-064	76	802-058	28	804-020	16	805-068	17	808-035	21
718-027	25	801-065	76	802-059	28	804-021	16	805-069	17	808-036	21
718-028	25	801-067	76	802-060	28	804-022	16	806-001	19	808-037	21
718-029	25	801-068	76	802-061	28	804-023	16	806-002	19	808-038	21
718-030	25	801-069	76	802-062	28	804-024	16	806-003	19	808-039	21
718-031	25	801-070	76	802-063	28	804-025	16	806-004	19	808-040	21
718-032	25	801-115	73	802-064	28	804-026	16	806-005	19	808-041	21
718-033	25	801-127	74	802-065	28	804-027	16	806-006	19	808-042	21
718-034	25	801-128	74	802-066	28	804-028	16	806-007	19	808-043	21
718-035	25	801-129	74	802-067	28	804-029	16	806-008	19	808-044	21
718-036	25	801-130	74	802-068	28	804-030	16	806-009	19	808-045	21
718-037	25	801-131	74	802-069	28	804-031	16	806-010	19	808-046	21
718-038	25	801-145	75	802-070	28	804-032	16	806-011	19	808-047	21
718-039	25	801-146	75	802-090	28	804-033	16	806-012	19	808-048	21
718-040	25	801-147	75	802-091	28	804-034	16	806-013	19	808-049	21
718-041	25	801-148	75	802-092	28	804-035	16	806-014	19	808-050	21
718-042	25	801-149	75	802-093	28	804-036	16	806-015	19	808-051	21
718-044	25	801-200	77	802-094	28	804-037	16	806-016	19	808-052	21
718-046	25	801-201	77	802-095	28	804-038	16	806-017	19	808-053	21
718-048	25	801-202	77	802-096	28	804-039	16	806-018	19	808-054	21
718-050	25	801-204	77	802-097	28	804-040	16	806-019	19	808-055	21
718-052	25	801-205	77	802-098	28	804-041	16	806-020	19	808-056	21
718-054	25	801-206	77	802-099	28	804-042	16	806-021	19	808-057	21
718-056	25	801-208	77	802-100	28	804-043	16	806-022	19	808-059	21
718-059	25	801-210	77	802-101	28	804-044	16	806-023	19	808-060	21
721-014	25	801-211	77	802-102	28	804-045	16	806-024	19	808-061	21
721-015	25	801-212	77	802-103	28	804-046	16	806-025	19	809-009	30
721-016	25	801-213	77	802-104	28	804-047	16	807-001	29	809-009A	30
721-017	25	801-214	77	802-137	28	804-048	16	807-001A	29	809-010	30
721-018	25	801-215	77	802-138	28	804-049	16	807-002	29	809-010A	30
721-019	25	801-216	77	802-139	28	804-050	16	807-002A	29	809-011	30
721-020	25	801-217	77	802-201	28	804-051	16	807-003	29	809-011A	30
721-021	25	802-001	28	802-202	28	804-052	16	807-003A	29	809-012	30
721-022	25	802-002	28	802-203	28	804-053	16	807-004	29	809-012A	30
721-023	25	802-003	28	802-204	28	804-054	16	807-004A	29	809-013	30
721-024	25	802-004	28	802-205	28	804-055	16	807-005	29	809-013A	30
721-025	25	802-005	28	802-206	28	804-056	16	807-005A	29	809-014	30
721-030	25	802-005A	28	802-207	28	804-057	16	807-006	29	809-014A	30
721-031	25	802-006	28	802-208	28	804-058	16	807-006A	29	809-015	30
721-032	25	802-006A	28	803-011	14	804-059	16	807-007	29	809-016	30
721-033	25	802-007	28	803-012	14	804-060	16	807-007A	29	809-017	30
721-034	25	802-007A	28	803-013	14	804-061	16	807-008	29	809-018	30
721-035	25	802-008	28	803-014	14	804-062	16	807-008A	29	809-019	30
721-036	25	802-008A	28	803-015	14	804-063	16	807-009	29	809-020	30
721-037	25	802-009	28	803-016	14	804-064	16	807-009A	29	809-021	30
721-038	25	802-009A	28	803-017	14	804-065	16	807-010	29	809-022	30
721-039	25	802-010	28	803-018	14	804-066	16	807-010A	29	809-023	30
721-040	25	802-010A	28	803-019	14	804-067	16	807-011	29	809-024	30
721-041	25	802-011	28	803-020	14	804-068	16	807-011A	29	809-025	30
724-028	35	802-011A	28	803-021	14	804-069	16	807-012	29	809-026	30
724-032	35	802-012	28	803-022	14	805-013	17	807-012A	29	809-027	30
724-037	35	802-012A	28	803-023	14	805-014	17	807-013	29	809-028	30
724-057	35	802-013	28	803-024	14	805-015	17	807-013A	29	809-029	30
724-087	35	802-013A	28	803-025	14	805-016	17	807-014	29	809-030	30
801-003	73	802-014	28	803-026	14	805-017	17	807-014A	29	809-031	30
801-005	73	802-014A	28	803-027	14	805-018	17	807-015	29	809-032	30
801-006	73	802-015	28	803-028	14	805-019	17	807-016	29	809-033	30
801-009	73	802-015A	28	803-029	14	805-020	17	807-017	29	809-034	30
801-010	73	802-016	28	803-030	14	805-021	17	807-018	29	809-035	30
801-011	73	802-016A	28	803-031	14	805-022	17	807-019	29	809-036	30
801-012	73	802-017	28	803-032	14	805-023	17	807-020	29	809-037	30
801-013	73	802-017A	28	803-033	14	805-024	17	807-021	29	809-038	30
801-014	73	802-018	28	803-034	14	805-025	17	807-022	29	809-039	30
801-015	73	802-018A	28	803-035	14	805-026	17	807-023	29	809-040	30
801-016	73	802-019	28	803-036	14	805-027	17	807-024	29	809-041	30
801-017	73	802-020	28	803-037	14	805-028	17	807-025	29	809-042	30
801-018	73	802-021	28	803-038	14	805-029	17	807-026	29	809-043	30
801-019	73	802-022	28	803-039	14	805-030	17	807-027	29	81-#0-6	154
801-020	73	802-023	28	803-040	14	805-031	17	807-028	29	81-#10	154
801-021	73	802-024	28	803-041	14	805-032	17	807-029	29	81-#12	154
801-023	73	802-025	28	803-042	14	805-033	17	807-030	29	81-#8	154
801-025	73	802-026	28	803-043	14	805-034	17	807-030A	29	810-001	41
801-026	73	802-027	28	803-044	14	805-035	17	807-031	29	810-002	41
801-027	74	802-028	28	803-045	14	805-036	17	807-032	29	810-003	41
801-028	74	802-029	28	803-046	14	805-037	17	807-506	29	810-004	41
801-029	74	802-030	28	803-047	14	805-038	17	807-506A	29	810-005	41
801-030	74	802-031	28	803-048	14	805-039	17	808-006	21	810-006	41
801-031	74	802-032	28	803-049	14	805-040	17	808-007	21	810-007	41
801-032	74	802-032A	28	803-050	14						



PART NUMBER	PG.	PART NUMBER	PG.	PART NUMBER	PG.	PART NUMBER	PG.	PART NUMBER	PG.	PART NUMBER	PG.
810-011A	31	812-057	32	817-046	34	878-105	151	903-040	26	911-04531	8
810-012	31	812-058	32	817-047	34	878-106	151	903-041	26	911-04688	8
810-012A	31	812-059	32	817-048	34	878-107	151	903-045	26	911-04844	8
810-013	31	812-060	32	817-049	34	878-108	151	903-053	26	911-05000	8
810-013A	31	812-061	32	817-050	34	878-109	151	903-057	26	912-01875	10
810-014	31	812-062	32	817-051	34	878-110	151	905-013	27	912-02031	10
810-014A	31	812-085	32	817-052	34	886-001N	148	905-014	27	912-02188	10
810-015	31	812-086	32	817-053	34	886-002	148	905-015	27	912-02344	10
810-016	31	812-087	32	817-054	34	886-003N	148	905-016	27	912-02500	10
810-017	31	814-011	33	817-055	34	886-004	148	905-017	27	912-02656	10
810-018	31	814-012	33	817-056	34	886-005	148	905-018	27	912-02812	10
810-019	31	814-012A	33	817-057	34	886-006N	148	905-019	27	912-02969	10
810-020	31	814-013	33	817-058	34	886-007N	148	905-020	27	912-03125	10
810-021	31	814-013A	33	817-059	34	886-008	148	905-021	27	912-03281	10
810-022	31	814-014	33	817-060	34	886-010	150	905-022	27	912-03438	10
810-023	31	814-014A	33	817-061	34	886-025	150	905-023	27	912-03594	10
810-024	31	814-015	33	817-062	34	886-031	150	905-024	27	912-03750	10
810-025	31	814-016	33	817-085	34	886-037	150	905-025	27	912-03906	10
810-026	31	814-017	33	817-087	34	886-043	150	905-026	27	912-04062	10
810-027	31	814-018	33	819-012	35	886-050	150	905-027	27	912-04219	10
810-028	31	814-019	33	819-012A	35	886-062	150	905-028	27	912-04375	10
810-029	31	814-020	33	819-013	35	886-075	150	905-029	27	912-04531	10
810-030	31	814-021	33	819-013A	35	886-087	150	905-030	27	912-04688	10
810-031	31	814-022	33	819-014	35	886-099	150	905-031	27	912-04844	10
810-032	31	814-023	33	819-014A	35	886-101	150	905-032	27	912-05000	10
810-033	31	814-024	33	819-015	35	886-102	150	905-033	27	912-05156	10
810-034	31	814-025	33	819-016	35	886-103	150	905-034	27	912-05312	10
810-035	31	814-026	33	819-019	35	886-104	150	905-035	27	914-01875	10
810-036	31	814-027	33	819-021	35	886-105	150	905-036	27	914-02031	10
810-037	31	814-028	33	819-022	35	886-106	150	905-037	27	914-02188	10
810-038	31	814-029	33	819-023	35	886-110	150	905-038	27	914-02344	10
810-039	31	814-030	33	819-027	35	886-111	150	905-039	27	914-02500	10
810-040	31	814-031	33	819-029	35	886-125	150	905-040	27	914-02656	10
810-041	31	814-032	33	819-030	35	886-131	150	905-041	27	914-02812	10
810-042	31	814-033	33	819-031	35	886-137	150	905-042	27	914-02969	10
810-043	31	814-034	33	819-032	35	886-143	150	905-043	27	914-03125	10
810-043A	31	814-035	33	819-033	35	886-149	150	905-044	27	914-03281	10
810-044	31	814-036	33	819-034	35	886-155	150	905-045	27	914-03438	10
810-045	31	814-037	33	819-035	35	886-175	150	905-046	27	914-03594	10
810-046	31	814-038	33	819-037	35	886-187	150	905-047	27	914-03750	10
810-047	31	814-039	33	819-038	35	886-194	150	905-048	27	914-03906	10
810-048	31	814-040	33	819-040	35	886-200	150	905-049	27	914-04062	10
810-049	31	814-041	33	819-046	35	886-201	150	905-050	27	914-04219	10
81-012PLS	154	814-042	33	819-049	35	886-203	150	905-051	27	914-04375	10
81-012PSS	154	814-043	33	819-056	35	886-205	150	905-057	27	914-04531	10
81-025	154	814-044	33	819-058	35	886-207	150	908-034	27	914-04688	10
81-031	154	814-045	33	819-059	35	886-209	150	908-035	27	914-04844	10
81-037	154	814-046	33	819-061	35	886-305	149	908-036	27	914-05000	10
81-043	154	814-047	33	819-062	35	886-307	149	908-041	27	914-05156	10
81-050	154	814-048	33	82-#0-6	154	886-401	150	908-042	27	914-05312	10
81-056	154	814-049	33	82-#10	154	886-402	150	908-044	27	916-01875	11
812-009	32	814-050	33	82-#12	154	886-403	150	908-046	27	916-02031	11
812-009A	32	814-051	33	82-#8	154	886-404	150	908-050	27	916-02187	11
812-010	32	814-052	33	82-012PLS	154	886-405	150	908-055	27	916-02344	11
812-010A	32	814-053	33	82-012PSS	154	886-406	150	908-058	27	916-02500	11
812-011	32	814-054	33	82-025	154	886-407	150	91-#0-6	155	916-02656	11
812-011A	32	814-055	33	82-025P	154	886-408	150	91-#10	155	916-02812	11
812-012	32	814-056	33	82-031	154	886-409	150	91-#12	155	916-02969	11
812-012A	32	814-057	33	82-037	154	886-410	150	91-#8	155	916-03125	11
812-013	32	814-058	33	82-037P	154	886-411	150	910-01875	8	916-03281	11
812-013A	32	814-059	33	82-043	154	886-412	150	910-02031	8	916-03438	11
812-014	32	814-060	33	82-050	154	886-413	150	910-02187	8	916-03594	11
812-014A	32	814-061	33	82-050P	154	886-500	150	910-02344	8	916-03750	11
812-015	32	814-062	33	82-056	154	886-502	150	910-02500	8	916-03906	11
812-016	32	814-085	33	82-062	154	886-504	150	910-02656	8	916-04062	11
812-017	32	814-086	33	82-068	154	886-506	150	910-02812	8	916-04219	11
812-018	32	814-087	33	82-075	154	886-508	150	910-02969	8	916-04375	11
812-019	32	817-012	34	82-081	154	886-510	150	910-03125	8	916-04531	11
812-020	32	817-012A	34	82-087	154	886-512	150	910-03281	8	916-04688	11
812-021	32	817-013	34	822-032	35	886-514	150	910-03438	8	916-04844	11
812-022	32	817-013A	34	822-037	35	886-516	150	910-03594	8	916-05000	11
812-023	32	817-014	34	822-045	35	886-518	150	910-03750	8	917-01875	12
812-024	32	817-014A	34	83-075P	154	886-520	150	910-03906	8	917-02187	12
812-025	32	817-015	34	83-081	154	886-522	150	910-04062	8	917-02344	12
812-026	32	817-016	34	83-087	154	886-524	150	910-04219	8	917-02500	12
812-027	32	817-017	34	83-093	154	886-526	150	910-04375	8	917-02656	12
812-028	32	817-018	34	83-1000	154	886-528	150	910-04531	8	917-02812	12
812-029	32	817-019	34	83-1000P	154	886-530	150	910-04688	8	917-02969	12
812-030	32	817-020	34	83-1012	154	886-532	150	910-04844	8	917-03125	12
812-031	32	817-021	34	83-1025	154	886-534	150	910-05000	8	917-03281	12
812-032	32	817-022	34	83-1037	154	886-536	150	91-012PLS	155	917-03438	12
812-033	32	817-023	34	831-201	119	886-538	150	91-012PSS	155	917-03750	12
812-034	32	817-024	34	831-202	119	903-013	26	91-025	155	917-03906	12
812-035	32	817-025	34	831-203	119	903-014	26	91-031	155	917-04062	12
812-036	32	817-026	34	831-204	119	903-015	26	91-037	155	917-04219	12
812-037	32	817-027	34	831-205	119	903-016	26	91-043	155	917-04375	12
812-038	32	817-028	34	831-206	119	903-017	26	91-050	155	917-05000	12
812-039	32	817-029	34	842-001	158	903-018	26	91-056	155	918-01875	13
812-040	32	817-030	34	842-002	158	903-019	26	911-01875	8	918-02187	13
812-041	32	817-031	34	842-003	158	903-020	26	911-02031	8	918-02344	13
812-042	32	817-032	34	842-004	158	903-021	26	911-02187	8	918-02500	13
812-043	32	817-033	34	842-005	158	903-022	26	911-02344	8	918-02656	13
812-044	32	817-034	34	842-006	158	903-023	26	911-02500	8	918-02812	13
812-045	32	817-035	34	842-007	158	903-024	26	911-02656	8	918-02969	13
812-046	32	817-036	34	842-008	158	903-025	26	911-02812	8	918-03125	13
812-047	32	817-037	34	843-002	158	903-026	26	911-02969	8	918-03281	13
812-048	32	817-038	34	843-003	158	903-027	26	911-03125	8	918-03438	13
812-049	32	817-039	34	873-001	149	903-028	26	911-03281	8	918-0375	



THE GEORGE WHALLEY COMPANY

www.coolantfedtooling.com

P: 800.600.2248

F: 216.481.9966

INDEX

PART NUMBER	PG.	PART NUMBER	PG.	PART NUMBER	PG.	PART NUMBER	PG.	PART NUMBER	PG.	PART NUMBER	PG.
919-01562	5	949-018	158	BT50-EM50-300	132	C40-MT2-175E	130	C45-MT3-231E	130	C50-EM31-250	127
919-01719	5	949-020	158	BT50-EM50-600	132	C40-MT2-219E	130	C45-MT3-DPOR-5	100	C50-EM37-300	127
919-01875	5	949-0748	158	BT50-EM62-300	132	C40-MT3-250D	130	C45-MT3-DPOR-5A	100	C50-EM37-450	127
919-02031	5	949-0787	158	BT50-EM62-600	132	C40-MT3-250E	130	C45-MT3-MG-5	106	C50-EM50-300	127
919-02187	5	949-0984	158	BT50-EM75-300	132	C40-MT3-275E	130	C45-MT3-MG-5A	106	C50-EM50-462	127
919-02344	5	949-1259	158	BT50-EM75-600	132	C40-MT3-MG-5	106	C45-MT3-SPFS-5	91	C50-EM62-375	127
919-02500	5	949-1579	158	BT50-EM87-400	132	C40-MT3-MG-5A	106	C45-MT3-SPFS-5A	91	C50-EM75-400	127
919-02656	5	AA106-MT2-CGH-3	122	BT50-ER20-393	131	C40-MT3-SPFS-5	91	C45-MT4-318D	130	C50-EM75-575	127
919-02812	5	AA106-MT3-CGH-4	122	BT50-ER32-400	131	C40-MT3-SPFS-5A	91	C45-MT4-318E	130	C50-EM75-DPOR-6	99
919-02969	5	AA106-TG10-CGH-5	121	BT50-MT2-236	133	C40-MT3-SPOR-5	97	C45-MT4-CGH-4	116	C50-EM75-MG-6	105
919-03125	5	AA10-DA18-CGH-4	121	BT50-MT3-295	133	C40-MT3-SPOR-5A	97	C45-MT4-DPOR-5	100	C50-EM75-SPFS-6	90
919-03281	5	AA10-DA18-CGH-5	121	BT50-MT3-DPOR-5	103	C40-MT4-350D	130	C45-MT4-DPOR-5A	100	C50-EM87-375	127
919-03438	5	AA10-MT3-CGH-4	122	BT50-MT3-MG-5	108	C40-MT4-350E	130	C45-MT4-MG-5	106	C50-EM87-400	127
919-03594	5	AA137-MT3-CGH-2	122	BT50-MT3-SPFS-5	94	C40-MT4-356E	130	C45-MT4-MG-5A	106	C50-ER16-400	126
919-03750	5	AA137-MT4-CGH-2	122	BT50-MT4-374	133	C40-MT4-MG-5	106	C45-MT4-SPFS-5	91	C50-ER16-600	126
919-03906	5	AA137-TG10-CGH-5	121	BT50-MT4-DPOR-5	104	C40-MT4-MG-5A	106	C45-MT4-SPFS-5A	91	C50-ER20-400	126
919-04062	5	AA187-TG10-CGH-5	121	BT50-MT4-MG-5	108	C40-MT4-SPFS-5	91	C45-MT5-475D	130	C50-ER32-400	126
919-04219	5	AA188-MT3-CGH-2	122	BT50-MT4-SPFS-5	94	C40-MT4-SPFS-5A	91	C45-MT5-475E	130	C50-ER32-600	126
919-04375	5	AA188-MT4-CGH-2	122	BT50-MT5-413	133	C40-MT4-SPOR-5	97	C45-SM10-200	128	C50-FM20-240	129
919-04688	5	AA75-DA18-CGH-4	121	BT50-MT5-DPOR-5	104	C40-MT4-SPOR-5A	97	C45-SM10-225	128	C50-FM20-400	129
919-04844	5	AA75-MT2-CGH-3	122	BT50-MT5-MG-5	108	C40-PMC-0.750-085	37	C45-SM10C-200	128	C50-FM20-600	129
919-05000	5	AA87-DA18-CGH-4	121	BT50-MT5-SPFS-5	94	C40-PMC-1.250-090	37	C45-SM12-212	128	C50-FM25-240	129
919-05156	5	AA88-MT2-CGH-2	122	BT50-RT1-288	153	C40-RT1-275	152	C45-SM12-225	128	C50-FM25-400	129
919-05469	5	AI-0189T (45/50V)	109	BT50-RT2-369	153	C40-RT2-356	152	C45-SM12C 343	128	C50-FM25-600	129
919-05625	5	AI-0189Y (45/50V)	109	BT50-RT3-500	153	C40-SM10-100	128	C45-SM15-240	128	C50-JT1-215	129
920-01250	7	AI-9789T (40V)	109	BT50-SM10-175	132	C40-SM10-200	128	C45-SM15-245	128	C50-JT2-243	129
920-01406	7	AI-9789V (40V)	109	BT50-SM12-175	132	C40-SM10-400	128	C45-SM15-250	128	C50-JT3-280	129
920-01562	7	AI-9889N (40V)	109	BT50-SM15-175	132	C40-SM10C-194	128	C45-SM15-400	128	C50-JT3-281	129
920-01719	7	AI-9989S (45/50V)	109	BT50-SM20-300	132	C40-SM12-200	128	C45-SM15-405	128	C50-JT3-280	129
920-01875	7	AI-9989X (45/50V)	109	BT50-TC1-475	153	C40-SM12-400	128	C45-SM15C-400	128	C50-JT3-295	129
920-02031	7	AR-0689Z (45/50V)	109	BT50-TG2-550	153	C40-SM12C-343	128	C45-SM20-212	128	C50-JT4-325	129
920-02187	7	B40-PMC-0.750-075	37	BT50-TG3-694	153	C40-SM15-250	128	C45-SM50-150	128	C50-JT5-338	129
920-02344	7	B40-PMC-1.250-085	37	BT50-TG10-350	131	C40-SM15-400	128	C45-SM75-150	128	C50-JT6-259	129
920-02500	7	BT40-EM10-175	132	BT50-TG10-600	131	C40-SM50-138	128	C45-TG10-300	124	C50-MT2-200D	130
920-02656	7	BT40-EM10-350	132	BT50-TG10C-350	131	C40-SM50-350	128	C45-TG10-400	124	C50-MT2-200E	130
920-02812	7	BT40-EM10-MG-5	107	BT50-TG10C-600	131	C40-SM75-138	128	C45-TG10-550	124	C50-MT3-250D	130
920-02969	7	BT40-EM10-SPFS-5	94	BT50-TG10-DPOR-6	103	C40-SM75-350	128	C45-TG10-600	124	C50-MT3-250E	130
920-03125	7	BT40-EM10-SPOR-5	98	BT50-TG10-MG-6	107	C40-TC1-425	152	C45-TG10-750	124	C50-MT3-DPOR-5	100
920-03281	7	BT40-EM12-350	132	BT50-TG10-SPFS-6	93	C40-TG2-563	152	C45-TG10C-300	124	C50-MT3-DPOR-5A	100
920-03438	7	BT40-EM12-MG-5	107	BT50-TG15-350	131	C40-TG10-300	124	C45-TG10C-400	124	C50-MT3-MG-5	106
920-03594	7	BT40-EM12-SPFS-5	94	BT50-TG15C-350	131	C40-TG10-500	124	C45-TG10C-550	124	C50-MT3-MG-5A	106
920-03750	7	BT40-EM12-SPOR-5	98	BT886-003N	148	C40-TG10-600	124	C45-TG10C-600	124	C50-MT3-SPFS-5	91
920-03906	7	BT40-EM15-450	132	BT886-006N	148	C40-TG10-650	124	C45-TG10C-750	124	C50-MT3-SPFS-5A	91
920-04062	7	BT40-EM37-250	132	BT886-007N	148	C40-TG10C-300	124	C45-TG10C-DPOR-6	99	C50-MT4-337E	130
920-04219	7	BT40-EM37-400	132	C40-ABS40-MG-6	106	C40-TG10C-500	124	C45-TG10-MG-6	104	C50-MT4-338D	130
920-04375	7	BT40-EM50-175	132	C40-ABS40-SPFS-6	92	C40-TG10C-600	124	C45-TG10P-400	125	C50-MT4-CGH-4	116
920-04688	7	BT40-EM50-250	132	C40-ABS40-SPOR-6	96	C40-TG10C-650	124	C45-TG10-SPFS-6	90	C50-MT4-DPOR-5	100
920-04844	7	BT40-EM50-400	132	C40-ABS50-MG-6	106	C40-TG10-MG-6	104	C45-TG15-300	124	C50-MT4-DPOR-5A	100
920-05000	7	BT40-EM62-250	132	C40-ABS50-SPFS-6	92	C40-TG10P-400	125	C45-TG15-400	124	C50-MT4-MG-5	106
92-025P	155	BT40-EM62-400	132	C40-ABS50-SPOR-6	96	C40-TG10-SPFS-6	90	C45-TG15-600	124	C50-MT4-MG-5A	106
92-031	155	BT40-EM75-250	132	C40-BB4-11	130	C40-TG10-SPOR-6	95	C45-TG15-800	124	C50-MT4-SPFS-5	91
92-037	155	BT40-EM75-400	132	C40-DA18-295	125	C40-TG15-488	124	C45-TG15C-300	124	C50-MT4-SPFS-5A	91
92-037P	155	BT40-EM75-MG-6	107	C40-DA18-400	125	C40-TG15C-488	124	C45-TG15C-400	124	C50-MT5-475D	130
92-043	155	BT40-EM75-SPFS-6	94	C40-DA18-MG-7	105	C45-ABS40-DPOR-6	100	C45-TG15C-600	124	C50-MT5-475E	130
92-050	155	BT40-EM75-SPOR-6	98	C40-DA18P-6	126	C45-ABS40-MG-6	106	C45-TG15C-800	124	C50-MT5-CGH-5	116
92-050P	155	BT40-EM87-350	132	C40-DA18-SPFS-7	91	C45-ABS40-SPFS-6	92	C45-TG15P-400	125	C50-MT5-DPOR-5	100
92-056	155	BT40-ER20-393	131	C40-DA18-SPOR-7	95	C45-ABS50-DPOR-6	100	C50-ABS40-DPOR-6	100	C50-MT5-MG-5	106
92-062	155	BT40-ER32-400	131	C40-EM10-300	127	C45-ABS50-MG-6	106	C50-ABS40-DPOR-6	100	C50-MT5-SPFS-5	91
92-068	155	BT40-JT2-264	133	C40-EM10-338	127	C45-ABS50-SPFS-6	92	C50-ABS40-MG-6	106	C50-PMC-0.750-105	37
92-068	155	BT40-JT3-298	133	C40-EM10-400	127	C45-ABS63-DPOR-6	100	C50-ABS40-SPFS-6	92	C50-PMC-1.250-090	37
92-075	155	BT40-JT33-277	133	C40-EM10-MG-6	105	C45-ABS63-MG-6	106	C50-ABS50-DPOR-6	100	C50-PMC-1.250-105	37
92-081	155	BT40-JT6-277	133	C40-EM10-SPFS-6	90	C45-ABS63-SPFS-6	92	C50-ABS50-MG-6	106	C50-RT1-275	152
92-087	155	BT40-MT2-177	133	C40-EM10-SPOR-6	96	C45-BB4-110	130	C50-ABS50-SPFS-6	92	C50-RT12-356	152
921-02500	36	BT40-MT2-MG-5	108	C40-EM12-200	127	C45-BB4-64	130	C50-ABS63-DPOR-5	100	C50-RT3-488	152
921-03750	36	BT40-MT2-SPFS-5	94	C40-EM12-300	127	C45-EM10-400	127	C50-ABS63-MG-5	106	C50-SM10-200	128
921-05000	36	BT40-MT2-SPOR-5	98	C40-EM12-425	127	C45-EM10-100	127	C50-ABS63-SPFS-5	92	C50-SM10-400	128
921-07500	36	BT40-MT3-295	133	C40-EM12-625	127	C45-EM10-DPOR-5	99	C50-BB4-11	130	C50-SM12-225	128
922-02500	36	BT40-MT3-MG-5	108	C40-EM12-MG-5	105	C45-EM10-MG-5	105	C50-BB4-17	130	C50-SM12-550	128
922-03750	36	BT40-MT3-SPFS-5	94	C40-EM12-SPFS-5	90	C45-EM10-SPFS-5	90	C50-BB6-07	130	C50-SM12-525	128
922-05000	36	BT40-MT3-SPOR-5	98	C40-EM12-SPOR-5	96	C45-EM12-400	127	C50-DA18P-6	126	C50-SM15-240	128
922-07500	36	BT40-MT4-374	133	C40-EM12-SPOR-6	96	C45-EM12-DPOR-5	99	C50-EM10-262	127	C50-SM15-400	128
923-02500	36	BT40-MT4-MG-5	108	C40-EM15-462	127	C45-EM12-MG-5	105	C50-EM10-400	127	C50-SM15-245	128
923-03750	36	BT40-MT4-SPFS-5	94	C40-EM18-250	127	C45-EM12-SPFS-5	90	C50-EM10-600	127	C50-SM15-405	128
923-05000	36	BT40-MT4-SPOR-5	98	C40-EM25-250	127	C45-EM15-400	127	C50-EM10-800	127	C50-SM15-600	128
923-06250	36	BT40-MT4-RT1-275	153	C40-EM31-250	127	C45-EM15-462	127	C50-EM10-DPOR-6	99	C50-SM16-600	128
923-07500	36	BT40-RT2-356	153	C40-EM37-250	127	C45-EM15-DPOR-5	99	C50-EM10-MG-6	105	C50-SM20-240	128
924-02500	36	BT40-SM10-175	132	C40-EM37-450	127	C45-EM15-MG-5	105	C50-EM10-SPFS-6	90	C50-SM20-400	128
924-03750	36	BT40-SM12-200	132	C40-EM50-175	127	C45-EM15-SPFS-5	90	C50-EM12-400	127	C50-SM20-600	128
924-05000	36	BT40-SM15-212	132	C40-EM50-462	127	C45-EM20-525	127	C50-EM12-600	127	C50-SM25-240	128
924-06250	36	BT40-SM75-175	132	C40-EM60-662	127	C45-EM37-225	127	C50-EM12-CGH-7	115	C50-SM50-150	128
924-07500	36	BT40-TC1-488	153	C40-EM62-175	127	C45-EM37-250	127	C50-EM12-DPOR-5	99	C50-SM50-250	128
93-050P	155	BT40-TC2-562	153	C40-EM62-300	127	C45-EM37-300	127	C50-EM12-MG-5	105	C50-SM75-150	128
93-075P	155	BT40-TG10-350	131	C40-EM62-338	127	C45-EM50-262	127	C50-EM12-SPFS-5	90	C50-SM75-350	128
93-081	155	BT40-TG10-550	131	C40-EM62-575	127	C45-EM50-300	127	C50-EM15-400	127	C50-TC1-400	152
93-087	155	BT40-TG10C-350	131	C40-EM75-175	127	C45-EM62-300	127	C50-EM15-CGH-7	115	C50-TC2-475	152
93-093	155	BT40-TG									

PART NUMBER	PG.	PART NUMBER	PG.	PART NUMBER	PG.	PART NUMBER	PG.	PART NUMBER	PG.	PART NUMBER	PG.
C50-TG15C-350	124	DA18-0750	147	ER32-150	145	M804-0105	19	M918-02756	13	M920-02913	7
C50-TG15C-550	124	DA20-0047	147	ER32-150C	144	M804-0110	19	M918-03150	13	M920-02953	7
C50-TG15C-750	124	DA20-0062	147	ER32-160	145	M804-0115	19	M918-03346	13	M920-02992	7
C50-TG15-CGH-8P	115	DA20-0078	147	ER32-160C	144	M804-0120	19	M918-03543	13	M920-03031	7
C50-TG15P-400	125	DA20-0094	147	ER32-170	145	M804-0130	19	M918-03740	13	M920-03071	7
CFT-1000	162	DA20-0109	147	ER32-170C	144	M903-110	26	M918-03937	13	M920-03150	7
CGH-0937	112	DA20-0125	147	ER32-180	145	M903-115	26	M918-04331	13	M920-03189	7
CGH-1250	112	DA20-0141	147	ER32-180C	144	M905-115	26	M919-01181	6	M920-03228	7
CGH-1500	112	DA20-0156	147	ER32-190	145	M905-125	26	M919-01260	6	M920-03268	7
CGH-1625	112	DA20-0172	147	ER32-190C	144	M905-135	26	M919-01299	6	M920-03346	7
CGH2-1250	113	DA20-0188	147	ER32-200	145	M905-155	26	M919-01339	6	M920-03465	7
CGH2-1500	113	DA20-0203	147	ER32-200C	144	M905-165	26	M919-01378	6	M920-03504	7
CGH2-2000	113	DA20-0219	147	FB-0750MS	70	M905-175	26	M919-01457	6	M920-03543	7
CGH2-2000A	113	DA20-0234	147	FB-0812MS	70	M905-185	26	M919-01496	6	M920-03622	7
CGH-2250	112	DA20-0250	147	FB-0875MS	70	M905-195	26	M919-01575	6	M920-03642	7
CGH2-2500	113	DA20-0266	147	FB-0937MS	70	M908-105	26	M919-01654	6	M920-03661	7
CGH2-2562	113	DA20-0281	147	FB-1000A	70	M908-110	26	M919-01772	6	M920-03740	7
CGH2-4250	113	DA20-0297	147	FB-1000B	70	M908-115	26	M919-01811	6	M920-03819	7
CGH-2750	112	DA20-0312	147	FB-1000MS	70	M908-120	26	M919-01890	6	M920-03858	7
CGH-3500	112	DA20-0328	147	FB-1062A	70	M908-125	26	M919-01929	6	M920-03937	7
CGH-4000	112	DA20-0344	147	FB-1062B	70	M908-130	26	M919-01968	6	M920-04016	7
CGS-0937	112	DA20-0359	147	FB-1125B	70	M908-135	26	M919-02008	6	M920-04134	7
CGS-1250	112	DA20-0375	147	FB-1187A	70	M908-140	26	M919-02047	6	M920-04331	7
CGS-1625	112	DA20-0391	147	FB-1187B	70	M908-145	26	M919-02087	6	M920-04409	7
CGS-2250	112	DA30-0031	147	FB-1250B	70	M908-150	26	M919-02126	6	M920-04527	7
CGS-2750	112	DA30-0047	147	FB-1312B	70	M908-155	26	M919-02165	6	M920-04606	7
DA10-0047	147	DA30-0062	147	FB-1437B	70	M910-01575	9	M919-02244	6	M920-04724	7
DA10-0062	147	DA30-0078	147	FB-1812C	70	M910-01772	9	M919-02283	6	M948-005	157
DA10-0078	147	DA30-0094	147	FB-2125D	70	M910-01890	9	M919-02323	6	M948-010	157
DA10-0094	147	DA30-0109	147	FB-2187D	70	M910-01968	9	M919-02362	6	M948-015	157
DA10-0109	147	DA30-0125	147	FB-2312D	70	M910-02165	9	M919-02402	6	M948-020	157
DA10-0125	147	DA30-0141	147	FB-2375D	70	M910-02283	9	M919-02441	6	M948-025	157
DA10-0141	147	DA30-0156	147	FB-2437D	70	M910-02362	9	M919-02480	6	M948-030	157
DA10-0156	147	DA30-0172	147	FB-2500D	70	M910-02559	9	M919-02520	6	M948-035	157
DA10-0172	147	DA30-0188	147	FB-2562E	71	M910-02677	9	M919-02559	6	M948-040	157
DA10-0188	147	DA30-0203	147	FB-2625E	71	M910-02756	9	M919-02677	6	M948-045	157
DA10-0203	147	DA30-0219	147	FB-2812E	71	M910-02953	9	M919-02717	6	M948-050	157
DA10-0219	147	DA30-0234	147	FB-2875E	71	M910-03071	9	M919-02756	6	M948-055	157
DA10-0234	147	DA30-0250	147	FB-3000E	71	M910-03150	9	M919-02835	6	M948-060	157
DA10-0250	147	E7353B (45/50V)	109	FB-3125F	71	M910-03346	9	M919-02913	6	MA100-080-A40	140
DA10-0266	147	E7353D (45/50V)	109	FB-3187F	71	M910-03465	9	M919-02953	6	MA100-080-A50	140
DA10-0281	147	E7353S (45/50V)	109	FB-3312F	71	M910-03543	9	M919-02992	6	MA100-080-A63	140
DA10-0297	147	E7353X (45/50V)	109	FB-3437F	71	M910-03750	9	M919-03031	6	MA100-080-A80	140
DA10-0312	147	ER16-010	145	FB-3562G	71	M910-03858	9	M919-03071	6	MA100-085-A100	140
DA10-0328	147	ER16-020	145	FB-3625G	71	M910-03937	9	M919-03150	6	MA100-125-A100	140
DA10-0344	147	ER16-030	145	FB-3687G	71	M910-04016	9	M919-03189	6	MA25-045-A25	140
DA10-0359	147	ER16-040	145	FB-3750G	71	M910-04134	9	M919-03228	6	MA25-060-A25	140
DA10-0375	147	ER16-040C	144	FB-3812G	71	M910-04252	9	M919-03268	6	MA25-EM0.250-055	143
DA10-0391	147	ER16-050	145	FB-3875G	71	M910-04331	9	M919-03346	6	MA25-EM0.312-055	143
DA10-0406	147	ER16-050C	144	FB-3937G	71	M911-01575	9	M919-03465	6	MA25-EM0.375-060	143
DA10-0422	147	ER16-060	145	FB-4000G	71	M911-01772	9	M919-03504	6	MA25-EM06MM-055	142
DA10-0438	147	ER16-060C	144	FB-4125H	71	M911-01890	9	M919-03543	6	MA25-EM08MM-055	142
DA10-0453	147	ER16-070	145	FB-4625H	71	M911-01968	9	M919-03622	6	MA25-EM10MM-060	142
DA10-0469	147	ER16-070C	144	FB-4750H	71	M911-02165	9	M919-03642	6	MA25-ER16-040	141
DA10-0484	147	ER16-080	145	FM-DA10-4	118	M911-02283	9	M919-03661	6	MA32-040-A25	140
DA10-0500	147	ER16-080C	144	H63-PMC-0.750-095	37	M911-02362	9	M919-03740	6	MA32-050-A32	140
DA10-0516	147	ER16-090	145	H63-PMC-1.250-100	37	M911-02559	9	M919-03819	6	MA32-070-A32	140
DA10-0531	147	ER16-090C	144	JT2-DA10-CGH-2	119	M911-02677	9	M919-03858	6	MA32-EM0.250-055	143
DA10-0547	147	ER16-100	145	JT33-DA18-CGH-2	119	M911-02756	9	M919-03937	6	MA32-EM0.312-055	143
DA10-0562	147	ER16-100C	144	KT200-EM10-DPOR-5	102	M911-02953	9	M919-04016	6	MA32-EM0.375-060	143
DA18-0047	147	ER20-020	145	KT200-TG10-DPOR-6P	102	M911-03071	9	M919-04134	6	MA32-EM0.500-065	143
DA18-0062	147	ER20-030	145	KT300-EM12-DPOR-5	102	M911-03150	9	M919-04331	6	MA32-EM06MM-055	142
DA18-0078	147	ER20-040	145	KT300-EM15-DPOR-5	102	M911-03346	9	M919-04409	6	MA32-EM08MM-055	142
DA18-0094	147	ER20-040C	144	KT300-TG10-DPOR-6P	102	M911-03465	9	M919-04527	6	MA32-EM10MM-060	142
DA18-0109	147	ER20-050	145	M604-0050	15	M911-03543	9	M919-04606	6	MA32-EM12MM-065	142
DA18-0125	147	ER20-050C	144	M604-0055	15	M911-03750	9	M919-04724	6	MA32-ER16-040	141
DA18-0141	147	ER20-060	145	M604-0060	15	M911-03858	9	M919-04764	6	MA32-ER20-053	141
DA18-0156	147	ER20-060C	144	M604-0065	15	M911-03937	9	M919-04921	6	MA40-040-A25	140
DA18-0172	147	ER20-070	145	M604-0068	15	M911-04016	9	M919-05039	6	MA40-040-A32	140
DA18-0188	147	ER20-070C	144	M604-0070	15	M911-04134	9	M919-05118	6	MA40-040-A40	140
DA18-0203	147	ER20-080	145	M604-0075	15	M911-04252	9	M919-05315	6	MA40-060-A40	140
DA18-0219	147	ER20-080C	144	M604-0078	15	M911-04331	9	M919-05394	6	MA40-090-A40	140
DA18-0234	147	ER20-090	145	M604-0080	15	M916-01968	11	M919-05512	6	MA40-EM0.250-055	143
DA18-0250	147	ER20-090C	144	M604-0085	15	M916-02165	11	M920-01181	7	MA40-EM0.312-055	143
DA18-0266	147	ER20-100	145	M604-0090	15	M916-02283	11	M920-01260	7	MA40-EM0.375-060	143
DA18-0281	147	ER20-100C	144	M604-0095	15	M916-02362	11	M920-01299	7	MA40-EM0.500-065	143
DA18-0297	147	ER20-110	145	M604-0100	15	M916-02559	11	M920-01339	7	MA40-EM0.625-070	143
DA18-0312	147	ER20-110C	144	M604-0102	15	M916-02677	11	M920-01378	7	MA40-EM06MM-055	142
DA18-0328	147	ER20-120	145	M604-0105	15	M916-02756	11	M920-01457	7	MA40-EM08MM-055	142
DA18-0344	147	ER20-120C	144	M604-0110	15	M916-02953	11	M920-01496	7	MA40-EM10MM-060	142
DA18-0359	147	ER20-130	145	M604-0115	15	M916-03071	11	M920-01575	7	MA40-EM12MM-065	142
DA18-0375	147	ER20-130C	144	M604-0120	15	M916-03150	11	M920-01654	7	MA40-EM16MM-070	142
DA18-0391	147	ER32-030	145	M604-0125	15	M916-03346	11	M920-01772	7	MA40-ER16-040	141
DA18-0406	147	ER32-040	145	M604-0130	15	M916-03465	11	M920-01811	7	MA40-ER20-053	141
DA18-0422	147	ER32-040C	144	M604-0135	15	M916-03543	11	M920-01890	7	MA40-ER25-062	141
DA18-0438	147	ER32-050	145	M604-0140	15	M916-03740	11	M920-01929	7	MA50-050-A25	140
DA18-0453	147	ER32-050C	144	M804-0030	19	M916-03858	11	M920-01968	7	MA50-050-A32	140
DA18-0469	147	ER32-060	145	M804-0033	19	M916-03937	11	M920-02008	7	MA50-050-A40	140
DA18-0484	147	ER32-060C	144	M804-0035	19	M916-04016	11	M920-02047	7	MA50-050-A50	140
DA18-0500	147	ER32-070	145	M804-0040	19	M916-04134	11	M920-02087	7	MA50-065-A50	140
DA18-0516	147	ER32-070C	144	M804-0042	19	M916-04331	11	M920-02126	7	MA50-100-A50	140
DA18-0531	147	ER32-080	145	M804-0045	19	M917-01968	12	M920-02165	7	MA50-EM0.250-055	143
DA18-0547	147	ER32-080C	144	M804-0050	19						



PART NUMBER	PG.	PART NUMBER	PG.	PART NUMBER	PG.	PART NUMBER	PG.	PART NUMBER	PG.	PART NUMBER	PG.
MA50-ER16-040	141	MT3-MT3-CGH-5	123	SA115	51	SA452	57	SB-1750B	65	SB-2718D-T	66
MA50-ER20-053	141	MT3-MT4-CGH-5	123	SA117	51	SA454	57	SB-1750B-T	65	SB-2718E	67
MA50-ER25-062	141	MT3-MT5-CGH-5	123	SA119	51	SA456	57	SB-1750C	65	SB-2718F-T	67
MA50-ER32-070	141	MT3-TG10-CGH-6P	122	SA120	51	SA458	57	SB-1750C-T	65	SB-2750D	66
MA63-060-A25	140	MT4-DA18-175	135	SA122	51	SA460	57	SB-1781C	65	SB-2750D-T	66
MA63-060-A32	140	MT4-DA18-CGH-6P	123	SA124	51	SB-0672MS	64	SB-1781C-T	65	SB-2750E	67
MA63-060-A40	140	MT4-MT4-CGH-6	123	SA125	51	SB-0672MS-T	64	SB-1812C	65	SB-2750E-T	67
MA63-060-A50	140	MT4-MT5-CGH-6	123	SA127	51	SB-0687MS	64	SB-1812C-T	65	SB-2781D	66
MA63-060-A63	140	MT4-TG10-312	135	SA129	51	SB-0687MS-T	64	SB-1843C	65	SB-2781D-T	66
MA63-085-A63	140	MT4-TG10-CGH-6P	122	SA131	51	SB-0718MS	64	SB-1843C-T	65	SB-2781E	67
MA63-125-A63	140	MT5-MT5-CGH-8	123	SA133	51	SB-0718MS-T	64	SB-1875C	65	SB-2781E-T	67
MA63-EM0.250-055	143	MT5-MT6-CGH-8	123	SA134	51	SB-0750MS	64	SB-1875C-T	65	SB-2812D	66
MA63-EM0.312-055	143	MT5-TG15-CGH-7P	122	SA242	52	SB-0750MS-T	64	SB-1906C	65	SB-2812D-T	66
MA63-EM0.375-060	143	MT6-TG15-CGH-7P	122	SA244	52	SB-0781MS	64	SB-1906C-T	65	SB-2812E	67
MA63-EM0.500-065	143	N30-EM75-4	117	SA246	52	SB-0781MS-T	64	SB-1937C	65	SB-2812E-T	67
MA63-EM0.625-070	143	N40-EM10-4	117	SA248	52	SB-0812MS	64	SB-1937C-T	65	SB-2843D	66
MA63-EM0.750-075	143	N40-MT2-CGH-4	117	SA249	52	SB-0812MS-T	64	SB-1968C	65	SB-2843D-T	66
MA63-EM06MM-055	142	N40-MT3-CGH-4	117	SA251	52	SB-0843MS	64	SB-1968C-T	65	SB-2843E	67
MA63-EM08MM-055	142	N40-TG10P-7	116	SA253	52	SB-0843MS-T	64	SB-2000C	65	SB-2843E-T	67
MA63-EM1.000-080	143	N40-TG15P-7	116	SA255	52	SB-0875MS	64	SB-2000C-T	65	SB-2875D	66
MA63-EM10MM-060	142	N50-EM12-7	117	SA257	52	SB-0875MS-T	64	SB-2000D	66	SB-2875D-T	66
MA63-EM12MM-065	142	N50-EM15-7	117	SA258	52	SB-0906MS	64	SB-2000D-T	66	SB-2875E	67
MA63-EM16MM-070	142	N50-EM17-7	117	SA260	52	SB-0906MS-T	64	SB-2031C	65	SB-2875E-T	67
MA63-EM20MM-075	142	N50-EM20-7	117	SA262	52	SB-0937MS	64	SB-2031C-T	65	SB-2906E	67
MA63-EM25MM-080	142	N50-EM22-7	117	SA264	52	SB-0937MS-T	64	SB-2031D	66	SB-2906E-T	67
MA63-ER16-040	141	N50-EM25-7	117	SA266	52	SB-0968A	64	SB-2031D-T	66	SB-2937E	67
MA63-ER20-053	141	N50-EM30-10	117	SA267	52	SB-0968A-T	64	SB-2062C	65	SB-2937E-T	67
MA63-ER25-062	141	N50-EM75-5	117	SA269	52	SB-0968MS	64	SB-2062C-T	65	SB-2968E	67
MA63-ER32-070	141	N50-MT3-CGH-5	117	SA271	53	SB-0968MS-T	64	SB-2062D	66	SB-2968E-T	67
MA63-ER40-079	141	N50-MT4-CGH-3	117	SA273	53	SB-1000A	64	SB-2062D-T	66	SB-3000E	67
MA80-060-A32	140	N50-MT5-CGH-3	117	SA275	53	SB-1000A-T	64	SB-2093C	65	SB-3000E-T	67
MA80-060-A40	140	N50-MT5-CGH-7	117	SA276	53	SB-1000MS	64	SB-2093C-T	65	SB-3000F	68
MA80-060-A50	140	N50-TG10P-7	116	SA278	53	SB-1000MS-T	64	SB-2093D	66	SB-3000F-T	68
MA80-060-A63	140	N50-TG15P-7	116	SA279	53	SB-1031A	64	SB-2093D-T	66	SB-3031E	67
MA80-070-A80	140	S606*-01	39	SA280	53	SB-1031A-T	64	SB-2125C	65	SB-3031E-T	67
MA80-085-A80	140	S606*-02	39	SA282	53	SB-1062A	64	SB-2125C-T	65	SB-3031F	68
MA80-125-A80	140	S606*-03	39	SA283	53	SB-1062A-T	64	SB-2125D	66	SB-3031F-T	68
MA80-EM0.500-065	143	S606*-04	39	SA285	53	SB-1093A	64	SB-2125D-T	66	SB-3062E	67
MA80-EM0.625-070	143	S606*-05	39	SA287	53	SB-1093A-T	64	SB-2156C	65	SB-3062E-T	67
MA80-EM0.750-075	143	S606*-06	39	SA289	53	SB-1125A	64	SB-2156C-T	65	SB-3062F	68
MA80-EM1.000-080	143	S606*-07	39	SA291	53	SB-1125A-T	64	SB-2156D	66	SB-3062F-T	68
MA80-EM1.250-090	143	S606*-08	39	SA292	53	SB-1156A	64	SB-2156D-T	66	SB-3093E	67
MA80-EM16MM-070	142	S606*-09	39	SA294	53	SB-1156A-T	64	SB-2187C	65	SB-3093E-T	67
MA80-EM20MM-075	142	S606*-10	39	SA296	53	SB-1187A	64	SB-2187C-T	65	SB-3093F	68
MA80-EM25MM-080	142	S606*-12	39	SA298	53	SB-1187A-T	64	SB-2187D	66	SB-3093F-T	68
MA80-EM32MM-090	142	S606*-13	39	SA300	53	SB-1218A	64	SB-2187D-T	66	SB-3125E	67
MA80-ER16-040	141	S606*-14	39	SA301	53	SB-1218A-T	64	SB-2218C	65	SB-3125E-T	67
MA80-ER20-053	141	S606*-15	39	SA303	53	SB-1250A	64	SB-2218C-T	65	SB-3125F	68
MA80-ER25-062	141	S606*-16	39	SA305	53	SB-1250A-T	64	SB-2218D	66	SB-3125F-T	68
MA80-ER32-070	141	S607*-01	38	SA307	53	SB-1250B	65	SB-2218D-T	66	SB-3156E	67
MA80-ER40-079	141	S607*-02	38	SA309	53	SB-1250B-T	65	SB-2250C	65	SB-3156E-T	67
MBT40-A25-060	139	S607*-03	38	SA378	54	SB-1281A	64	SB-2250C-T	65	SB-3156F	68
MBT40-A25-STUB	138	S607*-04	38	SA380	54	SB-1281A-T	64	SB-2250D	66	SB-3156F-T	68
MBT40-A32-060	139	S607*-05	38	SA381	54	SB-1281B	65	SB-2281C	65	SB-3187E	67
MBT40-A32-STUB	138	S607*-06	38	SA382	54	SB-1281B-T	65	SB-2281C-T	65	SB-3187E-T	67
MBT40-A40-060	139	S607*-07	38	SA384	54	SB-1312A	64	SB-2281D	66	SB-3187F	68
MBT40-A40-STUB	138	S607*-08	38	SA385	54	SB-1312A-T	64	SB-2281D-T	66	SB-3187F-T	68
MBT40-A50-060	139	S607*-09	38	SA387	54	SB-1312B	65	SB-2312C	65	SB-3218E	67
MBT40-A50-STUB	138	S607*-10	38	SA388	54	SB-1312B-T	65	SB-2312C-T	65	SB-3218E-T	67
MBT40-A63-070	139	S607*-11	38	SA389	54	SB-1343A	64	SB-2312D	66	SB-3218F	68
MBT40-A63-STUB	138	S607*-12	38	SA391	54	SB-1343A-T	64	SB-2312D-T	66	SB-3218F-T	68
MBT50-A100-110	139	S607*-13	38	SA392	54	SB-1343B	65	SB-2343C	65	SB-3250E	67
MBT50-A100-STUB	138	S607*-14	38	SA394	54	SB-1343B-T	65	SB-2343C-T	65	SB-3250E-T	67
MBT50-A32-070	139	S607*-15	38	SA395	54	SB-1375A	64	SB-2343D	66	SB-3250F	68
MBT50-A32-STUB	138	S607*-16	38	SA396	54	SB-1375A-T	64	SB-2343D-T	66	SB-3250F-T	68
MBT50-A40-070	139	S607*-17	38	SA398	54	SB-1375B	65	SB-2375C	65	SB-3281E	67
MBT50-A40-STUB	138	S607*-18	38	SA399	54	SB-1375B-T	65	SB-2375C-T	65	SB-3281E-T	67
MBT50-A50-070	139	S607*-19	38	SA401	54	SB-1406B	65	SB-2375D	66	SB-3281F	68
MBT50-A50-STUB	138	S607*-20	38	SA402	55	SB-1406B-T	65	SB-2375D-T	66	SB-3281F-T	68
MBT50-A63-080	139	S607*-21	38	SA403	55	SB-1437B	65	SB-2406D	66	SB-3312E	67
MBT50-A63-STUB	138	S607*-22	38	SA405	55	SB-1437B-T	65	SB-2406D-T	66	SB-3312E-T	67
MBT50-A80-100	139	S607*-23	38	SA406	55	SB-1468B	65	SB-2437D	66	SB-3312F	68
MBT50-A80-STUB	138	S608*-01	40	SA408	55	SB-1468B-T	65	SB-2437D-T	66	SB-3312F-T	68
MC40-A25-060	139	S608*-02	40	SA409	55	SB-1500B	65	SB-2468D	66	SB-3343E	67
MC40-A25-STUB	138	S608*-03	40	SA410	55	SB-1500B-T	65	SB-2500D	66	SB-3343E-T	67
MC40-A32-060	139	S608*-04	40	SA412	55	SB-1500C	65	SB-2500D-T	66	SB-3343F	68
MC40-A32-STUB	138	S608*-05	40	SA413	55	SB-1500C-T	65	SB-2500E	66	SB-3343F-T	68
MC40-A40-060	139	S608*-06	40	SA415	55	SB-1531B	65	SB-2500E-T	66	SB-3375E	67
MC40-A40-STUB	138	S608*-07	40	SA416	55	SB-1531B-T	65	SB-2531D	66	SB-3375E-T	67
MC40-A50-075	139	S608*-08	40	SA417	55	SB-1531C	65	SB-2531D-T	66	SB-3375F	68
MC40-A50-STUB	138	S608*-09	40	SA419	55	SB-1562B	65	SB-2531E	67	SB-3375F-T	68
MC40-A63-STUB	138	S608*-10	40	SA420	55	SB-1562B-T	65	SB-2531E-T	67	SB-3406F	68
MC50-A100-125	139	S608*-11	40	SA422	55	SB-1562C	65	SB-2562D	66	SB-3437F	68
MC50-A100-STUB	138	S608*-12	40	SA423	55	SB-1562C-T	65	SB-2562D-T	66	SB-3437F-T	68
MC50-A32-060	139	S608*-13	40	SA424	56	SB-1593B	65	SB-2562E	67	SB-3468F	68
MC50-A32-STUB	138	S608*-14	40	SA426	56	SB-1593B-T	65	SB-2562E-T	67	SB-3468F-T	68
MC50-A40-060	139	S608*-15	40	SA427	56	SB-1593C	65	SB-2593D	66	SB-3500F	68
MC50-A40-STUB	138	S608*-16	40	SA429	56	SB-1593C-T	65	SB-2593D-T	66	SB-3500F-T	68
MC50-A50-060	139	SA089	50	SA430	56	SB-1625B	65	SB-2593E	67	SB-3500G	68
MC50-A50-STUB	138	SA090	50	SA431	56	SB-1625B-T	65	SB-2593E-T	67	SB-3500G-T	68
MC50-A63-080	139	SA092	50	SA433	56	SB-1625C	65	SB-2625D	66	SB-3531F	68
MC50-A63-090	139	SA094	50	SA434	56	SB-1625C-T	65	SB-2625D-T	66	SB-3531F-T	68
MC50-A63-STUB	138	SA096	50	SA436	56	SB-1656B	65	SB-2625E	67	SB-3531G	68
MC50-A80-100	139	SA098	50	SA437	56	SB-1656B-T	65	SB-2625E-T	67	SB-3531G-T	68
MC50-A80-STUB	138	SA099	50	SA438	56	SB-1656C	65	SB-2656D	66	SB-3562F	68
MT2-DA10-212	135	SA101	50	SA440	56	SB-1656C-T	65	SB-2656D-T	66	SB-3562G	68
MT2-DA18-238	135	SA102	50	SA441	56	SB-1687B	65	SB-2687E	67	SB-3562G-T	68
MT2-DA18-CGH-6P	123	SA104	50	SA443	56	SB-1687B-T	65	SB-2687E-T	67	SB-3593F	68
MT2-MT2-CGH-4	123	SA105	50	SA444	5						



PART NUMBER	PG.	PART NUMBER	PG.	PART NUMBER	PG.	PART NUMBER	PG.	PART NUMBER	PG.	PART NUMBER	PG.
SB-3593G-T	68	SB-5750H-T	69	SC381	54	SL002	48	SL176	51	SL534	51
SB-3625F	68	SB-5875H	69	SC382	54	SL003	48	SL177	51	SL536	51
SB-3625F-T	68	SB-5875H-T	69	SC384	54	SL004	48	SL178	51	SL538	51
SB-3625G	68	SB-6000H	69	SC385	54	SL005	48	SL179	51	SL539	51
SB-3625G-T	68	SB-6000H-T	69	SC387	54	SL006	48	SL180	51	SL541	51
SB-3656F	68	SB-6125H	69	SC388	54	SL007	48	SL181	51	SL543	51
SB-3656F-T	68	SB-6125H-T	69	SC389	54	SL008	48	SL182	51	SL544	51
SB-3656G	68	SB-6250H	69	SC391	54	SL009	48	SL183	51	SL546	51
SB-3656G-T	68	SB-6250H-T	69	SC392	54	SL010	48	SL184	51	SL548	51
SB-3687F	68	SB-6375H	69	SC394	54	SL011	48	SL185	51	SL550	51
SB-3687F-T	68	SB-6375H-T	69	SC395	54	SL012	48	SL186	51	SL552	51
SB-3687G	68	SB-6500H	69	SC396	54	SL013	48	SL187	51	SL553	51
SB-3687G-T	68	SB-6500H-T	69	SC398	54	SL014	48	SL188	51	SS10-DA10-S8	134
SB-3718F	68	SB-6625H	69	SC399	54	SL015	48	SL189	50	SS10-DA18-7	134
SB-3718F-T	68	SB-6625H-T	69	SC401	54	SL016	48	SL191	50	SS10-JT33-DA18-CGH-4	120
SB-3718G	68	SB-6750H	69	SC402	55	SL017	48	SL193	50	SS12-DA18-8	134
SB-3718G-T	68	SB-6750H-T	69	SC403	55	SL018	48	SL195	50	SS12-DA18-S8	134
SB-3750F	68	SB-6875H	69	SC405	55	SL019	48	SL310	52	SS12-EM10-CGH-5	119
SB-3750F-T	68	SB-6875H-T	69	SC406	55	SL020	49	SL311	52	SS12-EM12-CGH-6	119
SB-3750G	68	SB-7000H	69	SC408	55	SL021	49	SL312	52	SS12-EM15-CGH-6	119
SB-3750G-T	68	SB-7000H-T	69	SC409	55	SL022	49	SL313	52	SS12-EM62-CGH-5	119
SB-3781F	68	SB-7125H	69	SC410	55	SL023	49	SL314	52	SS12-EM75-CGH-5	119
SB-3781F-T	68	SB-7125H-T	69	SC412	55	SL024	49	SL315	52	SS12-MT2-CGH-4	118
SB-3781G	68	SB-7250H	69	SC413	55	SL025	49	SL316	52	SS12-MT3-CGH-6	118
SB-3781G-T	68	SB-7250H-T	69	SC415	55	SL026	49	SL317	52	SS12-MT4-CGH-6	118
SB-3812F	68	SB-7375H	69	SC416	55	SL027	49	SL318	52	SS12-TG10-CGH-10	120
SB-3812F-T	68	SB-7375H-T	69	SC417	55	SL028	49	SL319	52	SS15-DA18-8	134
SB-3812G	68	SBH-MS-001	72	SC419	55	SL029	49	SL321	52	SS15-MT1-4C	135
SB-3812G-T	68	SBH-MS-003	72	SC420	55	SL030	49	SL323	52	SS15-MT2-4C	135
SB-3843F	68	SBH-MS-004	72	SC422	55	SL031	49	SL325	52	SS15-MT2-CGH-4	118
SB-3843F-T	68	SBH-MS-005	72	SC423	55	SL032	49	SL326	52	SS15-MT3-CGH-6	118
SB-3843G	68	SBH-MS-006	72	SC424	56	SL033	49	SL328	52	SS15-TG10-9	134
SB-3843G-T	68	SC089	50	SC426	56	SL034	49	SL330	52	SS15-TG10-CGH-10	120
SB-3875F	68	SC090	50	SC427	56	SL035	49	SL332	52	SS17-MT3-6C	135
SB-3875F-T	68	SC092	50	SC429	56	SL036	49	SL334	52	SS17-MT4-6C	135
SB-3875G	68	SC094	50	SC430	56	SL037	49	SL335	52	SS20-TG15-12	134
SB-3875G-T	68	SC096	50	SC431	56	SL038	49	SL337	52	SS25-MT5-7C	135
SB-3906G	68	SC098	50	SC433	56	SL039	49	SL339	53	SS50-DA30-S7	134
SB-3906G-T	68	SC099	50	SC434	56	SL040	49	SL341	53	SS75-DA20-S8	134
SB-3937G	68	SC101	50	SC436	56	SL041	49	SL343	53	ST089	50
SB-3937G-T	68	SC102	50	SC437	56	SL043	48	SL344	53	ST090	50
SB-3968G	68	SC104	50	SC438	56	SL045	48	SL346	53	ST092	50
SB-3968G-T	68	SC105	50	SC440	56	SL048	48	SL347	53	ST094	50
SB-4000G	68	SC106	50	SC441	56	SL050	48	SL348	53	ST096	50
SB-4000G-T	68	SC108	51	SC443	56	SL053	48	SL350	53	ST098	50
SB-4000H	69	SC110	51	SC444	56	SL055	48	SL351	53	ST099	50
SB-4000H-T	69	SC111	51	SC445	56	SL056	48	SL353	53	ST101	50
SB-4062G	68	SC113	51	SC446	57	SL058	48	SL355	53	ST102	50
SB-4062G-T	68	SC114	51	SC447	57	SL060	48	SL357	53	ST104	50
SB-4062H	69	SC115	51	SC448	57	SL062	49	SL359	53	ST105	50
SB-4062H-T	69	SC117	51	SC449	57	SL063	49	SL360	53	ST106	50
SB-4125G	68	SC119	51	SC451	57	SL065	49	SL362	53	ST108	51
SB-4125G-T	68	SC120	51	SC452	57	SL067	49	SL364	53	ST110	51
SB-4125H	69	SC122	51	SC454	57	SL069	49	SL366	53	ST111	51
SB-4125H-T	69	SC124	51	SC456	57	SL071	49	SL368	53	ST113	51
SB-4187G	68	SC125	51	SC458	57	SL072	49	SL369	53	ST114	51
SB-4187G-T	68	SC127	51	SC460	57	SL074	49	SL371	53	ST115	51
SB-4187H	69	SC129	51	SDA10-108	144	SL075	49	SL373	53	ST117	51
SB-4187H-T	69	SC131	51	SDA10-115	144	SL076	49	SL375	53	ST119	51
SB-4250G	68	SC133	51	SDA10-121	144	SL078	49	SL377	53	ST120	51
SB-4250G-T	68	SC134	51	SDA10-129	144	SL080	49	SL462	48	ST122	51
SB-4250H	69	SC242	52	SDA10-133	144	SL081	49	SL464	48	ST124	51
SB-4250H-T	69	SC244	52	SDA18-109	144	SL136	50	SL467	48	ST125	51
SB-4312G	68	SC246	52	SDA18-117	144	SL137	50	SL469	48	ST127	51
SB-4312G-T	68	SC248	52	SDA18-121	144	SL138	50	SL472	48	ST129	51
SB-4312H	69	SC249	52	SDA18-133	144	SL139	50	SL474	48	ST131	51
SB-4312H-T	69	SC251	52	SDA18-141	144	SL140	50	SL475	48	ST133	51
SB-4375G	68	SC253	52	SDA20-109	144	SL141	50	SL477	48	ST134	51
SB-4375G-T	68	SC255	52	SDA20-117	144	SL142	50	SL479	48	ST242	52
SB-4375H	69	SC257	52	SDA20-121	144	SL143	50	SL481	49	ST244	52
SB-4375H-T	69	SC258	52	SDA30-107	144	SL144	50	SL482	49	ST246	52
SB-4437H	69	SC260	52	SDA30-114	144	SL145	50	SL484	49	ST248	52
SB-4437H-T	69	SC262	52	SER16-040	144	SL146	50	SL486	49	ST249	52
SB-4500H	69	SC264	52	SER16-040C	144	SL147	50	SL488	49	ST251	52
SB-4500H-T	69	SC266	52	SER20-040	144	SL148	50	SL490	49	ST253	52
SB-4562H	69	SC267	52	SER20-040C	144	SL149	50	SL491	49	ST255	52
SB-4562H-T	69	SC269	52	SER32-040	144	SL150	50	SL493	49	ST257	52
SB-4625H	69	SC271	53	SER32-040C	144	SL151	50	SL495	49	ST258	52
SB-4625H-T	69	SC273	53	SH-22000S-075L	58	SL152	50	SL497	49	ST260	52
SB-4687H	69	SC275	53	SH-22005S-075L	58	SL153	50	SL499	49	ST262	52
SB-4687H-T	69	SC276	53	SH-22010S-075L	58	SL154	50	SL500	49	ST264	52
SB-4750H	69	SC278	53	SH-22010S-100L	58	SL155	50	SL502	50	ST266	52
SB-4750H-T	69	SC279	53	SH-22015S-075L	58	SL156	50	SL504	50	ST267	52
SB-4812H	69	SC280	53	SH-22015S-100L	58	SL157	50	SL506	50	ST269	52
SB-4812H-T	69	SC282	53	SH-22020S-100L	58	SL158	50	SL508	50	ST271	53
SB-4875H	69	SC283	53	SH-22020S-125L	58	SL159	50	SL509	50	ST273	53
SB-4875H-T	69	SC285	53	SH-22025S-100L	58	SL160	50	SL511	50	ST275	53
SB-4937H	69	SC287	53	SH-22025S-125L	58	SL161	51	SL513	50	ST276	53
SB-4937H-T	69	SC289	53	SH-22030S-125L	58	SL162	51	SL515	50	ST278	53
SB-5000H	69	SC291	53	SH-22030S-150L	58	SL163	51	SL517	50	ST279	53
SB-5000H-T	69	SC292	53	SH-220Y0S-075L	58	SL164	51	SL518	50	ST280	53
SB-5125H	69	SC294	53	SH-220Z0S-075L	58	SL165	51	SL520	50	ST282	53
SB-5125H-T	69	SC296	53	SH-23010S-100L	58	SL166	51	SL521	50	ST283	53
SB-5250H	69	SC298	53	SH-23015S-100L	58	SL167	51	SL523	50	ST285	53
SB-5250H-T	69	SC300	53	SH-23020S-125L	58	SL168	51	SL524	50	ST287	53
SB-5375H	69	SC301	53	SH-23025S-125L	58	SL169	51	SL525	50	ST289	53
SB-5375H-T	69	SC303	53	SH-23030S-150L	58	SL170	51	SL527	51	ST291	53
SB-5500H	69	SC305	53	SH-24000S-075L	58	SL171	51	SL528	51	ST292	53
SB-5500H-T	69	SC307	53	SH-24005S-075L	58	SL172	51	SL529	51	ST294	53
SB-5625H	69	SC309	53	SH-240Y0S-075L	58	SL173	51	SL530	51	ST296	53
SB-5625H-T	69	SC378	54	SH-240Z0S-075L	58	SL174	51	SL532	51	ST298	53
SB-5750H	69	SC380	54	SL001	48	SL175	51	SL533	51	ST300	53



PART NUMBER	PG.	PART NUMBER	PG.	PART NUMBER	PG.	PART NUMBER	PG.	PART NUMBER	PG.	PART NUMBER	PG.
ST301	53	SU028	49	SU330	52	TG10-0406	146	TG15-1484	146	WRK32614	166
ST303	53	SU029	49	SU332	52	TG10-0422	146	TG15-1500	146	WRK32621	166
ST305	53	SU030	49	SU334	52	TG10-0438	146	TGNP10-0375	145	WRK32749	165
ST307	53	SU031	49	SU335	52	TG10-0453	146	TGNP10-0500	145	WRK32751	164
ST309	53	SU032	49	SU337	52	TG10-0469	146	TGNP10-0625	145	WRK32912	166
ST378	54	SU033	49	SU339	53	TG10-0484	146	TGNP10-0750	145	WRK32913	166
ST380	54	SU034	49	SU341	53	TG10-0500	146	TGNP10-0875	145	WRK32914	164
ST381	54	SU035	49	SU343	53	TG10-0516	146	TGNP10-1000	145	WRK34217B	167
ST382	54	SU036	49	SU344	53	TG10-0531	146	V7419B (40V)	109	WRK34218B	165
ST384	54	SU037	49	SU346	53	TG10-0547	146	V7419J (40V)	109	WRK35000V	167
ST385	54	SU038	49	SU347	53	TG10-0562	146	V7419M (40V)	109	WRK35026	167
ST387	54	SU039	49	SU348	53	TG10-0578	146	WRK11111	164	WRK35030	164
ST388	54	SU040	49	SU350	53	TG10-0594	146	WRK11122	164	WRK35038	167
ST389	54	SU041	49	SU351	53	TG10-0609	146	WRK11122A	166	WRK35048B	167
ST391	54	SU043	48	SU353	53	TG10-0625	146	WRK11122A	167	WRK51011	166
ST392	54	SU045	48	SU355	53	TG10-0641	146	WRK11123	164	WRK51012	164
ST394	54	SU048	48	SU357	53	TG10-0656	146	WRK11125	166	WRK51013	166
ST395	54	SU050	48	SU359	53	TG10-0672	146	WRK11125	167	WRK51014	164
ST396	54	SU053	48	SU360	53	TG10-0688	146	WRK11126	166	WRK51015	166
ST398	54	SU055	48	SU362	53	TG10-0703	146	WRK11126A	166	WRK51016	164
ST399	54	SU056	48	SU364	53	TG10-0719	146	WRK11133	165	WRK51022	166
ST401	54	SU058	48	SU366	53	TG10-0734	146	WRK11135	165	WRK51022	167
ST402	55	SU060	48	SU368	53	TG10-0750	146	WRK1113D	166	WRK51023	164
ST403	55	SU062	49	SU369	53	TG10-0766	146	WRK11143	165	WRK51024	166
ST405	55	SU063	49	SU371	53	TG10-0781	146	WRK11144	165	WRK51024	167
ST406	55	SU065	49	SU373	53	TG10-0797	146	WRK11144A	167	WRK51025	164
ST408	55	SU067	49	SU375	53	TG10-0812	146	WRK11146	165	WRK51026	167
ST409	55	SU069	49	SU377	53	TG10-0828	146	WRK11148	167	WRK51033	167
ST410	55	SU071	49	SU378	53	TG10-0844	146	WRK11148A	167	WRK51037	167
ST412	55	SU072	49	SU379	53	TG10-0859	146	WRK11155	165	WRK51040	167
ST413	55	SU074	49	SU462	48	TG10-0875	146	WRK11314	164	WRK51041	165
ST415	55	SU076	49	SU464	48	TG10-0891	146	WRK12622	164	WRK51042	167
ST416	55	SU078	49	SU467	48	TG10-0906	146	WRK13744	165	WRK51043	165
ST417	55	SU080	49	SU469	48	TG10-0922	146	WRK17122	164	WRK51044	167
ST419	55	SU081	49	SU472	48	TG10-0938	146	WRK17123	164	WRK51045	165
ST420	55	SU136	50	SU474	48	TG10-0953	146	WRK17126	166	WRK51046	167
ST422	55	SU137	50	SU475	48	TG10-0968	146	WRK17127	166	WRK51047	165
ST423	55	SU138	50	SU477	48	TG10-0984	146	WRK17136	165	WRK51644	165
ST424	56	SU139	50	SU479	48	TG10-0998	146	WRK17144	165	WRK51648	165
ST426	56	SU140	50	SU481	49	TG10-1000	146	WRK17144	165	WRK71111	166
ST427	56	SU141	50	SU482	49	TG15-0500	146	WRK31109	166	WRK71111B	166
ST429	56	SU142	50	SU484	49	TG15-0516	146	WRK31109A	166	WRK71112	164
ST430	56	SU143	50	SU486	49	TG15-0531	146	WRK31109B	166	WRK71113	166
ST431	56	SU144	50	SU488	49	TG15-0547	146	WRK31109C	166	WRK71114	164
ST433	56	SU145	50	SU490	49	TG15-0562	146	WRK31113	166	WRK71122	166
ST434	56	SU146	50	SU491	49	TG15-0578	146	WRK31113A	166	WRK71122	167
ST436	56	SU147	50	SU493	49	TG15-0594	146	WRK31113B	166	WRK71123	164
ST437	56	SU148	50	SU495	49	TG15-0609	146	WRK31113E	166	WRK71124	166
ST438	56	SU149	50	SU497	49	TG15-0625	146	WRK31113F	166	WRK71124	167
ST440	56	SU150	50	SU499	49	TG15-0641	146	WRK31114	164	WRK71124B	166
ST441	56	SU151	50	SU500	49	TG15-0656	146	WRK31114A	164	WRK71125	164
ST443	56	SU152	50	SU502	50	TG15-0672	146	WRK31114A-P	164	WRK71133	166
ST444	56	SU153	50	SU504	50	TG15-0688	146	WRK31114B	164	WRK71134	165
ST445	56	SU154	50	SU506	50	TG15-0703	146	WRK31114B-P	164	WRK71135	166
ST446	57	SU155	50	SU508	50	TG15-0719	146	WRK31114D-P	164	WRK71135B	166
ST447	57	SU156	50	SU509	50	TG15-0734	146	WRK31114-P	164	WRK71136	165
ST448	57	SU157	50	SU511	50	TG15-0750	146	WRK31115	166	WRK71144	167
ST449	57	SU158	50	SU513	50	TG15-0766	146	WRK31115A	166	WRK71144	167
ST451	57	SU159	50	SU515	50	TG15-0781	146	WRK31115B	166	WRK71145	165
ST452	57	SU160	50	SU517	50	TG15-0797	146	WRK31116	165	WRK71146	167
ST454	57	SU161	51	SU518	50	TG15-0812	146	WRK31116A	165	WRK71146B	167
ST456	57	SU162	51	SU520	50	TG15-0828	146	WRK31116B	165	WRK71147	165
ST458	57	SU163	51	SU521	50	TG15-0844	146	WRK31117	167	WRK75022	164
ST460	57	SU164	51	SU523	50	TG15-0859	146	WRK31117A	167	WRKS00	163
STG10-111	144	SU165	51	SU524	50	TG15-0875	146	WRK31117B	167	WRKS30D	163
STG10-115	144	SU166	51	SU525	50	TG15-0891	146	WRK31117E	167	WRKS30M	163
STG10-121	144	SU168	51	SU527	51	TG15-0906	146	WRK31118	165	WRKS40M	163
STG10-130	144	SU169	51	SU528	51	TG15-0922	146	WRK31118A	165	WRKS45	163
STG10-141	144	SU170	51	SU529	51	TG15-0938	146	WRK31118A-P	165	WRKS45M	163
STG10-159	144	SU171	51	SU530	51	TG15-0953	146	WRK31118B	165	WRKS50	163
STG15-113	144	SU172	51	SU532	51	TG15-0968	146	WRK31118B-P	165	WRKS50M	163
STG15-117	144	SU173	51	SU533	51	TG15-0984	146	WRK31118D-P	165		
STG15-125	144	SU174	51	SU534	51	TG15-1000	146	WRK31118-P	165		
STG15-133	144	SU175	51	SU536	51	TG15-1016	146	WRK31138A	165		
STG15-149	144	SU176	51	SU538	51	TG15-1031	146	WRK31222	164		
STG15-165	144	SU177	51	SU539	51	TG15-1047	146	WRK31226	164		
SU001	48	SU178	51	SU541	51	TG15-1062	146	WRK31244A	165		
SU002	48	SU179	51	SU543	51	TG15-1078	146	WRK31246A	167		
SU003	48	SU180	51	SU544	51	TG15-1094	146	WRK31251A	165		
SU004	48	SU181	51	SU546	51	TG15-1109	146	WRK31514	164		
SU005	48	SU182	51	SU548	51	TG15-1125	146	WRK31614	164		
SU006	48	SU183	51	SU550	51	TG15-1141	146	WRK31616	164		
SU007	48	SU184	51	SU552	51	TG15-1156	146	WRK31617	164		
SU008	48	SU185	51	SU553	51	TG15-1172	146	WRK31643	167		
SU009	48	SU186	51	TG10-0094	146	TG15-1187	146	WRK31645	165		
SU010	48	SU187	51	TG10-0109	146	TG15-1203	146	WRK31647	165		
SU011	48	SU188	51	TG10-0125	146	TG15-1219	146	WRK31647H	165		
SU012	48	SU189	50	TG10-0141	146	TG15-1234	146	WRK31652	167		
SU013	48	SU191	50	TG10-0156	146	TG15-1250	146	WRK31814A	164		
SU014	48	SU193	50	TG10-0172	146	TG15-1266	146	WRK31843	167		
SU015	48	SU195	50	TG10-0188	146	TG15-1281	146	WRK31844A	165		
SU016	48	SU310	52	TG10-0203	146	TG15-1297	146	WRK32114	164		
SU017	48	SU311	52	TG10-0219	146	TG15-1312	146	WRK32114A	164		
SU018	48	SU312	52	TG10-0234	146	TG15-1328	146	WRK32114B	164		
SU019	48	SU313	52	TG10-0250	146	TG15-1344	146	WRK32114-C	164		
SU020	49	SU314	52	TG10-0266	146	TG15-1359	146	WRK32328	166		
SU021	49	SU315	52	TG10-0281	146	TG15-1375	146	WRK32414B	164		
SU022	49	SU316	52	TG10-0297	146	TG15-1391	146	WRK32418B	165		
SU023	49	SU317	52	TG10-0312	146	TG15-1406	146	WRK32419B	165		
SU024	49	SU318	52	TG10-0328	146	TG15-1422	146	WRK32420B	165		
SU025	49	SU319	52	TG10-0344	146	TG15-1438	146	WRK32611	166		
SU026	49	SU321	52	TG10-0359	146	TG15-1453	146	WRK32613	166		
SU027	49	SU323	52	TG10-0375	146	TG15-1469	146				
		SU325	52	TG10-0391	146						
		SU326	52								
		SU328	52								

**TERMS & CONDITIONS OF SALE**

All Prices are subject to change without notice

1. ORDERING INFORMATION**Standard Tools**

When ordering standard tools, please provide the part number listed in this catalog. Also, be sure to include any additional specifications required for optional coatings.

Special Tools

When ordering special tools, please supply a print of the desired tool or holder or give a detailed, accurate description along with necessary dimensions and specifications.

Minimum Order: \$25

2. DELIVERY

All prices are F.O.B Cleveland, Ohio, in U.S. dollars. All special shipping (Air Freight, etc.) will be sent freight collect.

3. CLAIMS

Since title and right of possession passes to the customer upon delivery to the carrier, any claims for damaged shipments must be made to the carrier.

4. TERMS

1%, 10 Days, Net 30

5. RETURN POLICY

- A. Orders for special tooling cannot be canceled or returned.
- B. Products discontinued from The George Whalley catalog cannot be returned.
- C. Unless shown to be defective, products that have been used in anyway cannot be returned.
- D. Products that have been altered in anyway cannot be returned.
- E. Products cannot be returned after 60 days from the date of the invoice.
- F. Products cannot be sent back before receiving return goods authorization and RGA number from The George Whalley Company. Such returned products must be accompanied by information giving the full quantity and description, date of purchase, customer purchase order number, The George Whalley Company invoice number, and any pertinent information requested on or attached to the RGA form. Return packages must be accompanied by The George Whalley Company RGA form and have RGA number clearly marked on the out side of the package. This procedure is intended to facilitate proper handling of your returns and the issuance of an RGA number does not imply acceptance of claims in advance.
- G. Outgoing tools are tools that will be discontinued when inventory is depleted. However, they may be available on a quotation basis.
- H. Any products returned without proper authorization or not passing inspection will be returned to the sender at their cost.
- I. Credit will be given based on the invoice price or the current price (whichever is lower), less a 15% handling and restocking charge (minimum charge: \$15.00).
- J. Freight costs both ways, must be paid by the customer. Special shipping costs will not be reimbursed.

6. LIABILITY

Any warranty implied by law, including warranties of merchantability or fitness for a particular purpose, are hereby disclaimed and excluded. No representative or person is authorized to give any other warranty or to assume for The George Whalley Company. The George Whalley Company will not be liable for any incidental or consequential damages. The products illustrated in this catalog are protected by United States and foreign patents, patents pending, and applied for. We have attempted to publish this catalog error free, however, we recommend inspection of tool dimensions prior to use. In addition, dimensions shown reflect current manufacturing standards and The George Whalley Company reserves the right to make changes, without notice, to incorporate design improvements.

**WARNING:
CUTTING TOOLS MAY SHATTER! ALWAYS WEAR EYE PROTECTION IN THE AREA OF THEIR USE.**